

Member IMC Group
Ingersoll
Cutting Tools

FINE GOLD

2013/2014



GOLD•RUSH

Milling	Description	Series	Page
	GOLD•RUSH GRADES	GOLD•RUSH grades for steel applications	10
	HI•POST+	12S1X, 12S1E	12
	HIPOS•TRIO 3H 90	1KJ1_, 1KJ1_ (TopOn), KJ	16
	DIPOS•HEXA 6D 90	1DJ1F, 1DJ1P, 1DJ1F, 1DJ1P (TopOn), DJ	20
	HI•QUAD	25J3P	24
	ISO•PLUS	DJ6T, DJ5T	26
	OCTO•PLUS	ON5H, ON6H, OP6N	28
	FORM•MASTER^F HIGH-FEED	1DG1H, 1DG1H (TopOn), DG6H	36
	HI•FEED^{MINI}	1TG1F, 1TG1F (TopOn), TG1F	40
	HI•QUAD^F	15M1P, 15M1PF (TopOn), 5M_P, 5G_M	44
	HI•QUAD	QHU, 5J1P	50
	ISO•PLUS	DD6H	52



Milling	Description	Series	Page
	DIPOSOTETRA™ 4D 90	1TJ1Q, 1TJ1Q (TopOn), TJ5Q, TJ6Q	54
	DIPOSOTETRA™ 4D 90	1TJ1N, 1TJ1N (TopOn), TJ5N, TJ6N	58
	DIPOSOTETRA™ 4D 90	1TN1N	62
	FORMMASTER™ SHEAR	15B1B, 15B1B (TopOn), 1A7_	64
	FORMMASTER™ PROFILE	1DE1H, 1DE1H (TopOn), DE6H	68
	FINISHBALL™ PROFILE	12A9, 12A5, 12A9 (TopOn), 12A8	72
	PROTRIO™ PROFILE	2TW7K	76
	GOLDMAX™ 4 FFIN	EF6J	78
	GOLDMAX™ 01-QUAD 90° FINE	VJ6K	80
	GOLDMAX™ 01-ED TO-FINE	3EJ6_ (Axial), 3EJ6_ (Radial)	82
	THINMAX™ TANGENTIAL	3VJ5V (Axial), 3VJ5V (Radial)	86

Turning	Description	Series	Page
	GOLD•RUSH GRADES	GOLD•RUSH grades for turning	102
	BLACK•RUSH GRADES	Turning grades for high speed machining of cast iron & alloy steel	104
	TOTURN™ WHISKER CERAMIC GRADE	Whisker reinforced ceramic grade TC430 for machining high strength & high temp alloys	108
	TOTURN™ NEW CBN GRADES	CBN grades TB610, TB670, TB730 for machining hardened steel & cast iron	112
	TOTURN™ PCD CHIPBREAKER	PCD-tipped inserts with CB chipbreaker	122
	TOTANK™	Size technology ISO turning inserts	126
	TOTANK™	Size technology external holders	135
	TOTANK™	Size technology boring bars	137
	GOLDB•DUTY	HB chipbreaker inserts for semi heavy turning	140
	GOLDB•DUTY	External holders	142
	TOFORCE LNMM HX	40mm helix insert for large part machining	146
	TOFORCE 2PLLNR/L	External tool holder for LNMM insert	147

Turning	Description	Series	Page
	ToFORCE 2PLBNR/L	External tool holder for LNMX inserts	148
	ToFORCE LNMX HD	50mm insert for large part machining	149
	ToFORCE LNMX HY	50mm insert for large part machining	149
	ToFORCE 1.25" INSERT	Double sided SNMD insert with 1.25" cutting edge	150
	ToFORCE HOLDERS FOR 1.25" INSERT	External holder for 1.25" SNMD inserts	151
	ToFORCE CNMD/SNMD	Double sided H series chipbreaker for rough & finish machining	152
	ToTURN EM CHIPBREAKER	EM chipbreaker for stainless steel machining	158
	ToTURN PC CHIPBREAKER	5°, 7°, & 11° positive inserts with PC chipbreaker	162
	ToTURN RCMX INSERTS	RA chipbreaker for positive round inserts	167
	ToTURN RCMX HOLDERS	External holders for positive round inserts (RCMX style)	168
	ToTURN RX CHIPBREAKER	RX chipbreakers for rough machining of large parts	170
	ToTURN SA CHIPBREAKER	7° positive inserts with SA chipbreaker	172

Turning	Description	Series	Page
	T•TURN™ KT CHIPBREAKER	KT chipbreaker for rough turning of cast iron	176
	T•FEED™	BNMX inserts for high feed machining	178
	T•FEED™	External holder for BNMX insert	179
	T•TURN™	External back clamping quick change holder for swiss type lathes	180
	T•MINI™ MINIATURE INDEXABLE BORING BARS	Indexable system of boring bars & inserts for small component machining	184
	T•MINI™ TSL SLEEVE	Sleeves to hold T•MINI boring bars	189
	T•MINI™ INSERTS	Inserts for T•MINI boring bars	190
	C•ADAPTER™	External quick change holder for ISO turning	192
	COMBI•CLAMP™ DCLS	Multi-function clamp for use with Ingersoll's existing T-type holders	200
	GOLD•RUSH™ GRADES	GOLD•RUSH grades for T•CLAMP applications	202
	GOLD•FLER™ HOLDERS	Holder for precision grooving, parting, and recessing	204
	GOLD•FLER™ INSERTS	4-edge inserts for precision grooving, parting, and recessing	208

Turning	Description	Series	Page
	TOMICRO™ SLEEVES	Sleeves, coolant fittings for mini carbide bars	212
	TOMICRO™	Mini carbide bars for internal machining	214
	TOCLAMP TTSIR/L	Internal grooving and turning on Small diameters	223
	TOCLAMP TGSIR/L	Internal shallow grooving & turning on small diameters	223
	TOCLAMP TTSER/L	External turning & grooving	224
	TOCLAMP TGSFR/L	Shallow external turning & grooving	224
	TOCLAMP TDIM	Pressed inserts for internal turning & grooving	225
	TOCLAMP TDIP	Precision inserts for internal turning & grooving	225
	TOTHREAD™ NEW GRADE TT5080	TT5080 for lathe threading applications	226
	TOTHREAD™ B-TYPE INSERTS	B-type threading inserts for excellent chip control and surface quality	230
	TOCLAMP ULTRA+™ TGBFR/L	Deep face grooving blade product expansion	234
	TOCLAMP ULTRA+™ TTIR/L	Internal turn/groove bars for deeper ID grooves	236

Turning	Description	Series	Page
	TOCLAMP ULTRA+ MODULAR	Modular system product expansion	238
	TOCLAMP ULTRA+	10mm & .375" wide inserts & holders	246
	TOCLAMP ULTRA+ NEW GRADE TT9080	New grade TT9080 phasing out grade TT9030	248
	TOGROOVE	Grooving system for special forms	250
	TOCAP NEW GROOVING INSERT	Multifunction tool for drilling, boring, facing, turning & grooving	252

Turning	Description	Series	Page
	GOLD-RUSH IN1030, IN2505, IN6505	Grades for holemaking	256
	GOLD-TWIST	Replaceable tip drill shanks	258
	GOLD-TWIST	Drill/chamfer combo solution for inch & metric tap sizes	274
	QUAD-TWIST DRILL	Indexable drill	276
	CHAMFERING RINGS	Replaceable tip drill shanks	286
	QUAD-DRILL+	QA adjustable drill	292
	DEEP-TWIST DEEP DRILL	HF series drills	298



GOLD•RUSH Grades

The ingenious solution that takes cutting tool materials to another level

- Stable and extended tool life in continuous and interrupted cutting operations
- Reduced cutting friction and minimized built-up edge on exotic materials
- High surface finish on the workpiece
- Improved adhesion and insert chipping resistance

CAST IRON

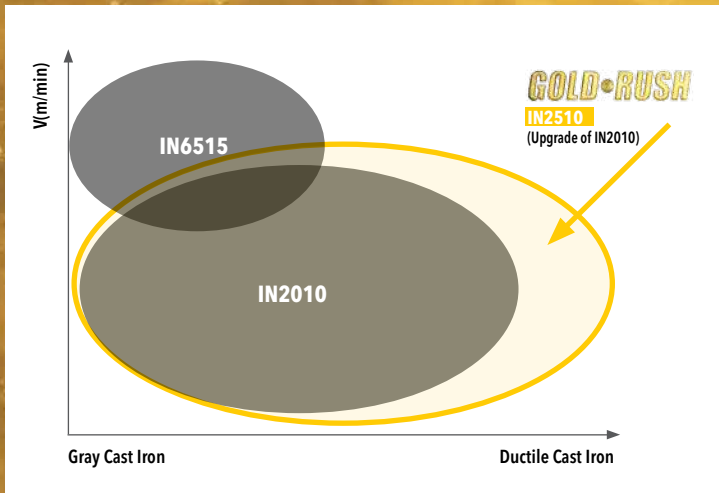

STEEL

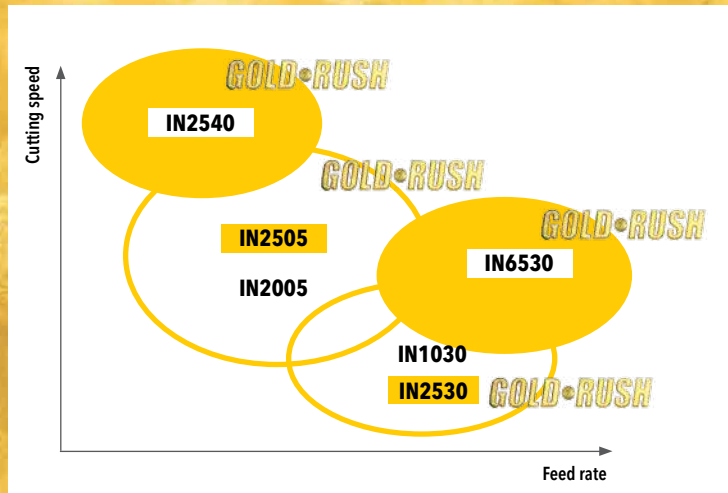

IN2510 (PVD)

- Grade with high wear resistance for general cast iron machining (Gray and Ductile cast iron milling)
- Extended tool life for medium and low speed machining
- Dedicated substrate for cast iron plus PVD coated grade with surface treatment after coating

K05-K20 N05-N20 H05-H20

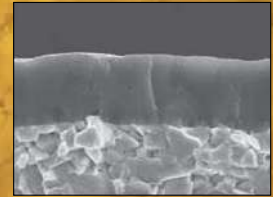

IN2540 (PVD)

- Excellent for alloy steels, mold steels and normal steels
- Has high wear, thermal crack resistance and high mechanical shock resistance
- Recommended for dry milling
- For medium to rough machining in Die & Mold application
- New yellow colored PVD coated grade with surface treatment after coating

P10-P40

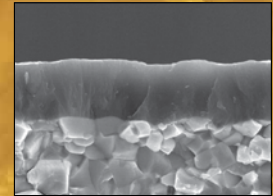

IN6530 (CVD)

- Grade for roughing of steels, alloy and stainless steels
- Excellent toughness with optimum wear resistance
- CVD coated grade with surface treatment after coating

M30-M45 P20-P45

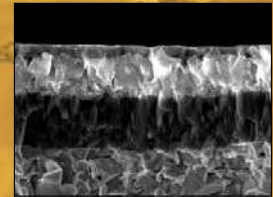

IN2505 (PVD)

- Excellent for low carbon, low alloy steels, alloy steels, mold steels and stainless steels
- Has high wear resistance and optimum toughness
- For medium to finish machining in Mold & Die
- Sub-micron substrate
- New yellow colored PVD coated grade with surface treatment after coating

M10-M30 P15-P35 S15-S25

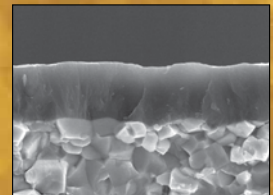

IN2530 (PVD)

- Grade for steel and stainless steel applications
- Good for medium to low speed application
- PVD coated grade with surface treatment after coating

M25-M40 P30-P45 S15-S30

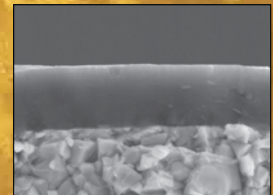



CENTER CUTTING ENDMILLS

- Upgraded performance with AOMT1805 and AOMT1204 series inserts.
- Cutter diameters from 1.00" thru 1.50" with through the tool coolant.
- Drill, ramp and pocket in one tool.
- Ramping up to 30° angles (without peck or dwell).
- Large variety of corner radii.



HIPOST+ SERIES 12S1X, 12S1E

CENTER CUTTING ENDMILL

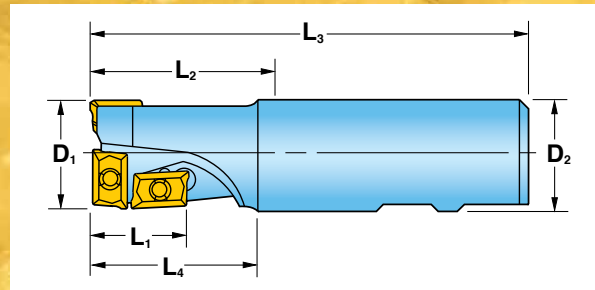

D1 Nom. Diameter	Cutter Number	L1 Max DOC	L2 Extension Length	L3 Overall Length	L4 Projection Length	D2 Shank Size/Style	No. of Effective Flutes	No. of Total Flutes	No. of Inserts Center	No. of Inserts Side	Insert Size
1.000	12S1X-1001780R01	0.87	1.75	4.00	1.60	1.000" W	1	2	1	2	1204
1.250	12S1X-1202781R01	0.93	2.75	5.00	2.60	1.250" W	1	2	1	2	1204
1.500	12S1E-1502781R01	1.26	2.75	5.00	2.75	1.250" W	1	2	1	2	1805

*Overall Length is measured to the sharp corner of the insert.
 † Use side inserts with corner radii no larger than .031"R.

Operating Guidelines on page 90.



Hi-POST™ 12MM INSERTS

AOCT120408FR-P

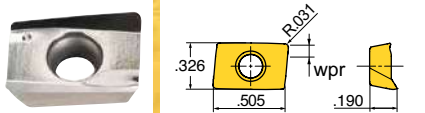

AOMT120404R

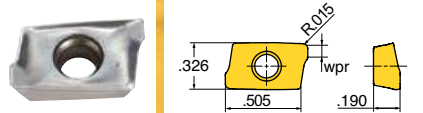

AOMT120408FR

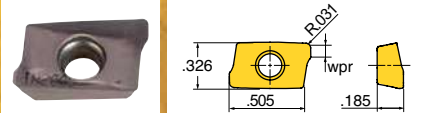

AOMT120408R

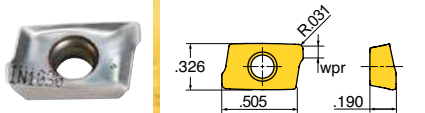

AOMT120416R

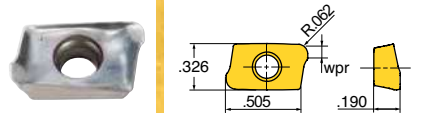

AOMT120424R

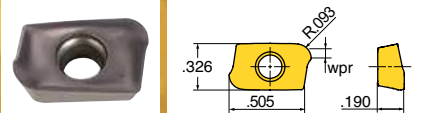

AOMT120430FR

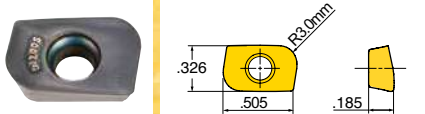

AOMT120432R

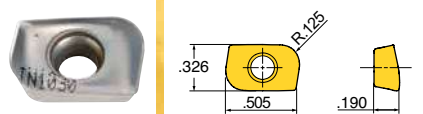

Part Number	Corner	Application	Grade									
				IN1030	IN10K	IN2005	IN2040	IN2505	IN2510	IN2530	IN2540	
AOMT120404R	0.015 R	Multi-Purpose		•		•						
AOMT120408R	0.031 R	Multi-Purpose		•		•		•	•	•	•	•
AOMT120416R	0.062 R	Multi-Purpose		•		•			•	•	•	•
AOMT120424R	0.093 R	Multi-Purpose				•						
AOMT120432R	0.125 R	Multi-Purpose		•		•	•					
AOMT120408FR	0.031 R	Hi-Temp/Ti				•					•	
AOMT120430FR	3.00 mm R	Multi-Purpose				•						
AOCT120408FR-P	0.031 R	Grd/Pol for Al			•							

HI^oPOST⁺ 18MM INSERTS

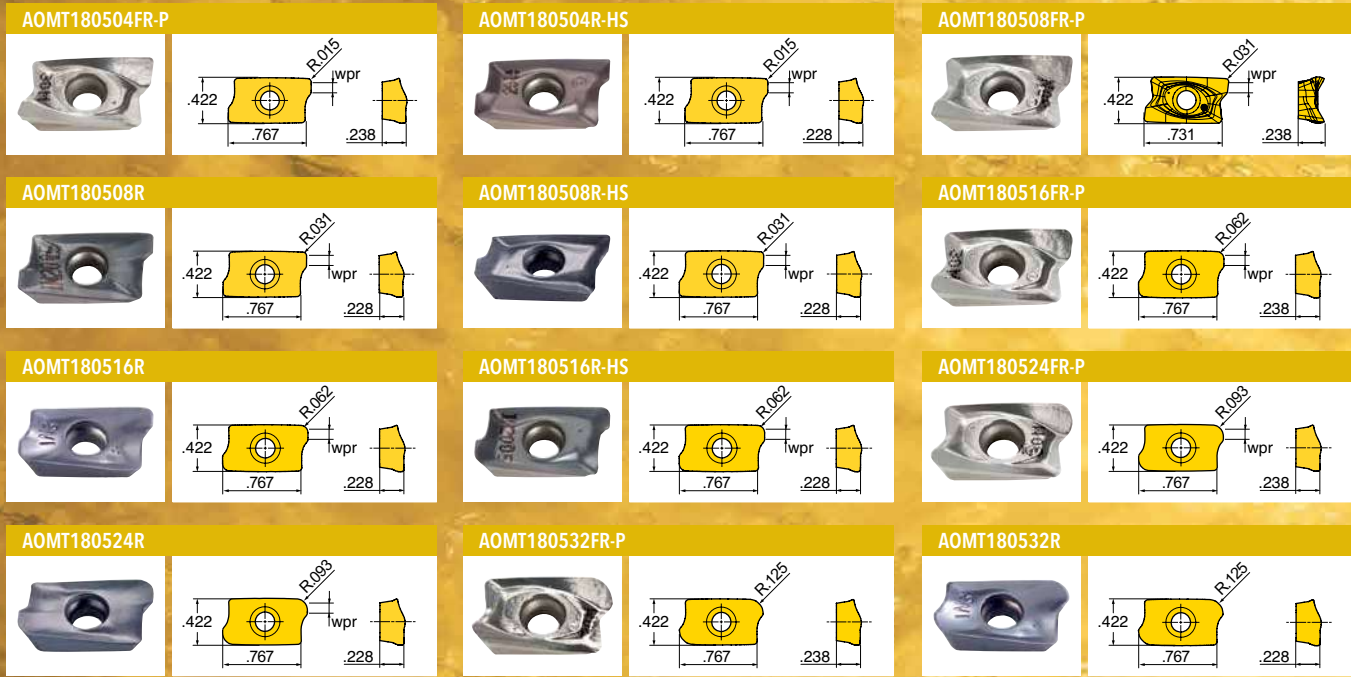

Part Number	Corner	Application	Grate	IN05S	IN1030	IN2005	IN2015	IN2030	IN2040	IN30M
AOMT180508R	0.031 R	Multi-Purpose		•	•	•	•	•		
AOMT180516R	0.062 R	Multi-Purpose		•	•	•	•	•		
AOMT180524R	0.093 R	Multi-Purpose		•	•				•	
AOMT180532R	0.125 R	Multi-Purpose		•	•	•	•	•		
AOMT180504FR-P	0.015 R	Grd/Pol for Al	•							
AOMT180504R-HS	0.015 R	Hi-Temp/Ti						•		
AOMT180508FR-P	0.031 R	Grd/Pol for Al								•
AOMT180508R-HS	0.031 R	Hi-Temp/Ti				•		•		•
AOMT180516FR-P	0.062 R	Grd/Pol for Al								•
AOMT180516R-HS	0.062 R	Hi-Temp/Ti				•				
AOMT180524FR-P	0.093 R	Grd/Pol for Al								•
AOMT180532FR-P	0.125 R	Grd/Pol for Al								•

HIPOST[™] HARDWARE

12MM



Screw

SM35-076-10



Driver

DS-T10T

18MM



Screw

SM40-093-20



Driver

DS-T15T

- Diameter Range From .625" to 6.00"
- Hi Positive Design with 3 Cutting Edges for Performance and Economy
- Ramping Capability for Cutting Versatility
- Three Insert Sizes for Complete Diameter Coverage
- Full Range of Insert Radii with Ingersoll Premium Grades

MILLING SOLUTIONS RAISED TO A TRIPLE GOLD PERFORMANCE STANDARD

HIPOSOTRIO™ SERIES 1KJ1_

0 DEGREE LEAD ENDMILL

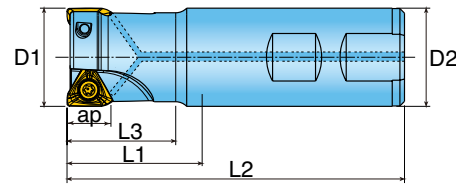

Cutter Number	D1 Effective Diameter	Number of Inserts	L1 Extension Length	L2 Overall Length	L3 Projection Length	D2 Shank Size/Style	Ramp Angle Using .031" R Insert	Insert Series	ap Cut Depth
1KJ1D-0601279R01	0.625	1	1.25	3.25	1.22	.625 W	4	TH_S06	.275
1KJ1D-0702084R01	0.725	2	2.00	4.00	1.80	.750 W	3.1	TH_S06	.275
1KJ1D-0701184R01	0.750	2	1.25	3.25	1.05	.750 W	3.1	TH_S06	.275
1KJ1D-0701784R01	0.750	2	1.75	3.75	1.55	.750 W	3.1	TH_S06	.275
1KJ1D-0703084R01	0.750	2	3.00	5.00	2.80	.750 W	3.1	TH_S06	.275
1KJ1D-0801784R01	0.875	2	1.75	3.75	1.75	.750 W	2.5	TH_S06	.275
1KJ1D-1001784R01	1.000	3	1.75	3.75	1.75	.750 W	2.15	TH_S06	.275
1KJ1D-1001780R01	1.000	3	1.75	4.00	1.55	1.00 W	2.15	TH_S06	.275
1KJ1D-1003780R01	1.000	3	3.75	6.00	3.375	1.00 W	N/A	TH_S06	.275
1KJ1D-1003784R01	1.000	3	3.75	6.00	3.55	.75 W	N/A	TH_S06	.275
1KJ1D-1201784R01	1.250	4	1.75	3.75	1.75	.750 W	1.5	TH_S06	.275
1KJ1D-1201780R01	1.250	5	1.75	4.00	1.75	1.00 W	1.5	TH_S06	.275
1KJ1D-1501784R01	1.500	5	1.75	3.75	1.75	.750 W	1.3	TH_S06	.275
1KJ1D-1501780R01	1.500	6	1.75	4.00	1.75	1.00 W	1.3	TH_S06	.275
1KJ1D-1502281R01	1.500	6	2.25	4.50	2.25	1.25 W	1.3	TH_S06	.275
1KJ1G-1201784R01	1.250	3	1.75	3.75	1.75	.750 W	2.3	TH_S10	.433
1KJ1G-1202281R01	1.250	2	2.25	4.50	2.05	1.25 W	2.3	TH_S10	.433
1KJ1G-1202281R02	1.250	3	2.25	4.50	2.05	1.25 W	2.3	TH_S10	.433
1KJ1G-1204281R01	1.250	3	4.25	6.50	4.05	1.25 W	N/A	TH_S10	.433
1KJ1G-1502281R01	1.500	3	2.25	4.50	2.20	1.25 W	1.8	TH_S10	.433
1KJ1G-1502281R02	1.500	4	2.25	4.50	2.20	1.25 W	1.8	TH_S10	.433
1KJ1G-1504281R01	1.500	3	4.25	6.50	4.25	1.25 W	N/A	TH_S10	.433
1KJ1G-2002281R01	2.000	5	2.25	4.50	2.25	1.25 W	1.5	TH_S10	.433
1KJ1P-2002281R01	2.000	4	2.25	4.50	2.25	1.25 W	1.5	TH_S13	.590

Operating Guidelines on page 91-92.



HIPOSOTRIO™ SERIES 1KJ1_ (TOP-ON STYLE)

0 DEGREE LEAD ENDMILL

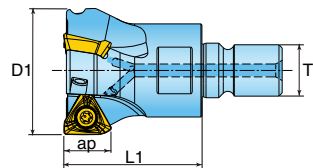

Cutter Number	D1 Nominal Diameter	Number of Inserts	L1 Extension Length	T1 Adaption	Wrench Size	Ramp Angle Using .031" R Insert	Insert Series	ap Cut Depth
1KJ1D-07015X6R01	0.750	2	1.50	M10	15mm	3.1	TH_S06	.275
1KJ1D-10015X7R01	1.000	2	1.50	M12	17mm	2.1	TH_S06	.275
1KJ1D-10015X7R02	1.000	3	1.50	M12	17mm	2.1	TH_S06	.275
1KJ1D-12017X8R01	1.250	3	1.75	M16	22mm	2.1	TH_S06	.275
1KJ1D-12017X8R02	1.250	5	1.75	M16	22mm	1.5	TH_S06	.275
1KJ1D-15017X8R01	1.500	5	1.75	M16	22mm	1.3	TH_S06	.275
*1KV1D-10015X7R01	1.000	3	1.50	M12	17mm	NA	TH_S06	.275
*1KV1D-12017X8R01	1.250	5	1.75	M16	22mm	NA	TH_S06	.275
1KJ1G-12017X8R01	1.250	3	1.50	M16	22mm	2.3	TH_S10	.433
1KJ1G-15017X8R01	1.500	4	1.75	M16	22mm	1.8	TH_S10	.433

* 3° Dovetail Endmill
Operating Guidelines on page 91-92.

0 DEGREE LEAD FACEMILL

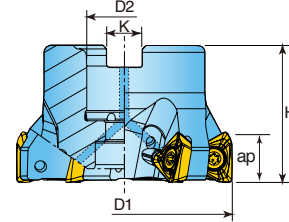

Cutter Number	D1 Effective Diameter	Number of Inserts	H Height	D2 Bore Diameter	Retention Bolt	Optional Coolant Bolt	K Keyway	Coolant	Ramp Angle Using .031" R Insert	Insert Series	ap Cut Depth
KJ5D-15R01	1.500	6	1.57	0.50	SD-04-85	-	0.25	Y	1	TH_S06	.275
KJ5D-20R01	2.000	7	1.57	0.75	SD-06-46	SD-06-89	0.31	Y	1	TH_S06	.275
KJ6D-30R01	3.000	9	1.75	1.00	SD-08-46	SD-08-92	0.38	Y	0.4	TH_S06	.275
KJ5G-20R01	2.000	5	1.57	0.75	SD-06-46	SD-06-89	0.31	Y	1.5	TH_S10	.433
KJ5G-25R01	2.500	6	1.57	0.75	SD-06-46	SD-06-89	0.31	Y	1.1	TH_S10	.433
KJ6G-30R01	3.000	5	1.75	1.00	SD-08-46	SD-08-92	0.38	Y	0.8	TH_S10	.433
KJ5G-30R01	3.000	8	1.75	1.00	SD-08-46	SD-08-92	0.38	Y	0.8	TH_S10	.433
KJ6G-40R01	4.000	8	1.75	1.50	-	-	0.62	N	0.6	TH_S10	.433
KJ5G-40R01	4.000	10	1.75	1.50	-	-	0.62	N	0.6	TH_S10	.433
KJ6G-50R01	5.000	11	2.00	1.50	-	-	0.62	N	0.5	TH_S10	.433
KJ6P-30R01	3.000	6	1.75	1.00	SD-08-46	SD-08-92	0.38	Y	1.3	TH_S13	.590
KJ6P-40R01	4.000	6	1.75	1.50	-	-	0.62	N	1	TH_S13	.590
KJ5P-40R01	4.000	8	1.75	1.50	-	-	0.62	N	1	TH_S13	.590
KJ6P-50R01	5.000	9	2.00	1.50	-	-	0.62	N	0.8	TH_S13	.590
KJ6P-60R01	6.000	8	2.00	1.50	-	-	0.62	N	0.6	TH_S13	.590
KJ5P-60R01	6.000	12	2.00	1.50	-	-	0.62	N	0.6	TH_S13	.590

Operating Guidelines on page 91-92.

HIPOSOTRIO™ INSERTS



Part Number	Application	R Corner	a Wiper	t Thick.	ap Cut Depth	Grade	IN10K	IN2505	IN2510	IN2530	IN2540
THLS060404R	Multi-Purpose	.015"R	.051	.157	.275			•			
THLS060408R	Multi-Purpose	.031"R	.035	.157	.275		•	•	•	•	•
THLS060416R	Multi-Purpose	.062"R	.022	.157	.275		•				
THLS060408FR	Hi-Temp	.031"R	.035	.157	.275		•		•		
THES060408R	Multi-Purpose, Ground Periphery	.031"R	.035	.157	.275		•				
THES060404FR-P	Ground/Polished for Aluminum	.015"R	.051	.157	.275		•				
THES060408FR-P	Ground/Polished for Aluminum	.031"R	.035	.157	.275		•				
THLS100508R	Multi-Purpose	.031"R	.063	.197	.433			•	•	•	•
THLS100516R	Multi-Purpose	.062"R	.032	.197	.433			•			
THLS100524R	Multi-Purpose	.093"R	.020	.197	.433			•			
THLS100508FR	Hi-Temp	.031"R	.063	.197	.433			•		•	
THES100508R	Multi-Purpose, Ground Periphery	.031"R	.063	.197	.433			•			
THES100516R	Multi-Purpose, Ground Periphery	.062"R	.031	.197	.433			•			
THES100508FR-P	Ground/Polished for Aluminum	.031"R	.063	.197	.433		•				
THLS130608R	Multi-Purpose	.031"R	.078	.236	.590			•	•	•	•
THLS130608FR	Hi-Temp	.031"R	.078	.236	.590			•		•	
THLS130616R	Multi-Purpose	.062"R	.047	.236	.590			•		•	
THLS130624R	Multi-Purpose	.093"R	.024	.236	.590			•			
THLS130632R	Multi-Purpose	.125"R	.020	.236	.590			•			
THES130608FR-P	Ground/Polished for Aluminum	.031"R	.078	.236	.590		•				

HIPOSOTRIO™ HARDWARE

	Insert Screw	Driver
KJ_D	SM25-065-R0	DS-T08W
KJ_G	SM40-100-R0	DS-T15T
KJ_P	SM45-120-R0	DS-T20T

DIPOS HEXA™

6D 90

DOUBLE SIDED POSITIVE INSERT WITH 6 CUTTING EDGES

- Diameter Range From 1.00" to 6.00"
- Helical Cutting Edge for 90 Degree Cutting
- Dovetail Insert Pocket Design Provides Increased Security and Insert Clamping
- Internal Coolant Supply
- Double Sided 6 Corner Insert



DIPOS HEXA™ SERIES 1DJ1F, 1DJ1P

6D 90

0 DEGREE LEAD ENDMILL WITH 6 INDEXES

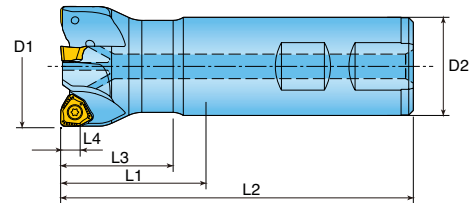

Cutter Number	D1 Effective Diameter	L4 Length of Cut	L3 Projection Length	L1 Extension Length	L2 Overall Length	D2 Shank Size/Style	Number of Inserts	Insert Series
1DJ1F-1001584R01	1.000	.24	1.50	1.50	3.50	.750 W	2	WNGU09
1DJ1F-1001780R01	1.000	.24	1.55	1.75	4.00	1.00 W	2	WNGU09
1DJ1F-1003780R01	1.000	.24	3.55	3.75	6.00	1.00 W	2	WNGU09
1DJ1F-1201584R01	1.250	.24	1.50	1.50	3.50	.750 W	3	WNGU09
1DJ1F-1202281R01	1.250	.24	2.22	2.25	4.50	1.25 W	3	WNGU09
1DJ1F-1204281R01	1.250	.24	4.22	4.25	6.50	1.25 W	3	WNGU09
1DJ1F-1502281R01	1.500	.24	2.25	2.25	4.50	1.25 W	4	WNGU09

Cutter Number	D1 Effective Diameter	L4 Length of Cut	L3 Projection Length	L1 Extension Length	L2 Overall Length	D2 Shank Size/Style	Number of Inserts	Insert Series
1DJ1P-1202281R01	1.250	.36	2.22	2.25	4.50	1.25 W	2	WNGU13
1DJ1P-1204281R01	1.250	.36	4.22	4.25	6.50	1.25 W	2	WNGU13
1DJ1P-1502281R01	1.500	.36	2.22	2.25	4.50	1.25 W	3	WNGU13
1DJ1P-1504281R01	1.500	.36	4.22	4.25	6.50	1.25 W	3	WNGU13
1DJ1P-2002281R01	2.000	.36	2.22	2.25	4.50	1.25 W	5	WNGU13

Operating Guidelines on page 92.



DIPOS[®]HEXA™ SERIES 1DJ1F, 1DJ1P (TOP-ON STYLE)

0 DEGREE LEAD ENDMILL WITH 6 INDEXES

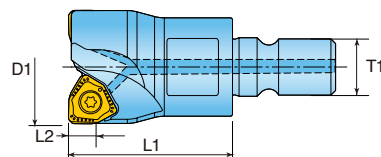

Cutter Number	D1 Effective Diameter	T1 Adaption	L1 Extension Length	L2 Length of Cut	Wrench Size	Number of Inserts	Insert Series
1DJ1F-10015X7R01	1.000	M12	1.50	.24	17mm	2	WNGU09
1DJ1F-12017X8R01	1.250	M16	1.75	.24	22mm	3	WNGU09
1DJ1F-15017X8R01	1.500	M16	1.75	.24	22mm	4	WNGU09

Cutter Number	D1 Effective Diameter	T1 Adaption	L1 Extension Length	L2 Length of Cut	Wrench Size	Number of Inserts	Insert Series
1DJ1P-12017X8R01	1.250	M16	1.75	.36	22mm	2	WNGU13
1DJ1P-15017X8R01	1.500	M16	1.75	.36	22mm	3	WNGU13
1DJ1P-15017X8R02	1.500	M16	1.75	.36	22mm	4	WNGU13

Operating Guidelines on page 92.

DIPOS[®]HEXA™ SERIES DJ_F, DJ_P

0 DEGREE LEAD FACEMILL WITH 6 INDEXES

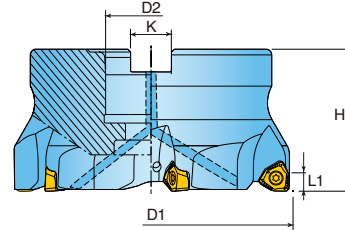

Cutter Number	D1 Effective Diameter	Number of Inserts	H Height	L1 Length of Cut	D2 Bore Diameter	K Keyway	Retention Bolt	Optional Coolant Bolt	Insert Series
DJ5F-20R01	2.000	5	1.570	.24	0.750	0.312	SD-06-46	SD-06-89	WNGU09
DJ5F-20R02	2.000	6	1.570	.24	0.750	0.312	SD-06-46	SD-06-89	WNGU09
DJ5F-25R01	2.500	6	1.570	.24	0.750	0.312	SD-06-46	SD-06-89	WNGU09
DJ5F-30R01	3.000	7	1.750	.24	1.000	0.375	SD-08-46	SD-08-92	WNGU09
DJ5F-30R02	3.000	9	1.750	.24	1.000	0.375	SD-08-46	SD-08-92	WNGU09
DJ5F-40R01	4.000	11	2.375	.24	1.500	0.625	SD-12-82	SD-12-99	WNGU09
DJ6F-40R01	4.000	8	2.375	.24	1.500	0.625	SD-12-82	SD-12-99	WNGU09

Cutter Number	D1 Effective Diameter	Number of Inserts	H Height	L1 Length of Cut	D2 Bore Diameter	K Keyway	Retention Bolt	Optional Coolant Bolt	Insert Series
DJ5P-20R01	2.000	5	1.570	.36	0.750	0.312	SD-06-46	SD-06-89	WNGU13
DJ6P-20R01	2.000	4	1.570	.36	0.750	0.312	SD-06-46	SD-06-89	WNGU13
DJ5P-25R01	2.500	6	1.570	.36	0.750	0.312	SD-06-46	SD-06-89	WNGU13
DJ5P-30R01	3.000	7	1.750	.36	1.000	0.375	SD-08-46	SD-08-92	WNGU13
DJ5P-30R02	3.000	9	1.750	.36	1.000	0.375	SD-08-46	SD-08-92	WNGU13
DJ5P-40R01	4.000	8	2.375	.36	1.500	0.625	SD-12-82	SD-12-99	WNGU13
DJ5P-40R02	4.000	11	2.375	.36	1.500	0.625	SD-12-82	SD-12-99	WNGU13
DJ6P-60R01*	6.000	12	2.000	.36	1.500	0.625	-	-	WNGU13

* No Coolant Through
Operating Guidelines on page 92.

DIPOS[®]HEXA™ HARDWARE



Insert Screw

Driver

WNGU09	SM30-085-10	DS-T09W
WNGU13	SM40-100-R0	DS-T15T

DIPOSOHEXA™ INSERTS



Part Number	Application	Grade	IN2505	IN2510	IN2530	IN2540	IN10K
WNGU090404R	Multi-Purpose - .015" R		●				
WNGU090405R	Multi-Purpose - .020" R (.5mm R)		●				
WNGU090408R	Multi-Purpose - .031" R		●	●	●	●	
WNGU090410R	Multi-Purpose - .039" R (1.0mm R)		●				
WNGU090416R	Multi-Purpose - .062" R		●	●	●		
WNGU090404FR-P	Grd/Pol for Aluminum - .015" R						●
WNGU090408FR-P	Grd/Pol for Aluminum - .031" R						●

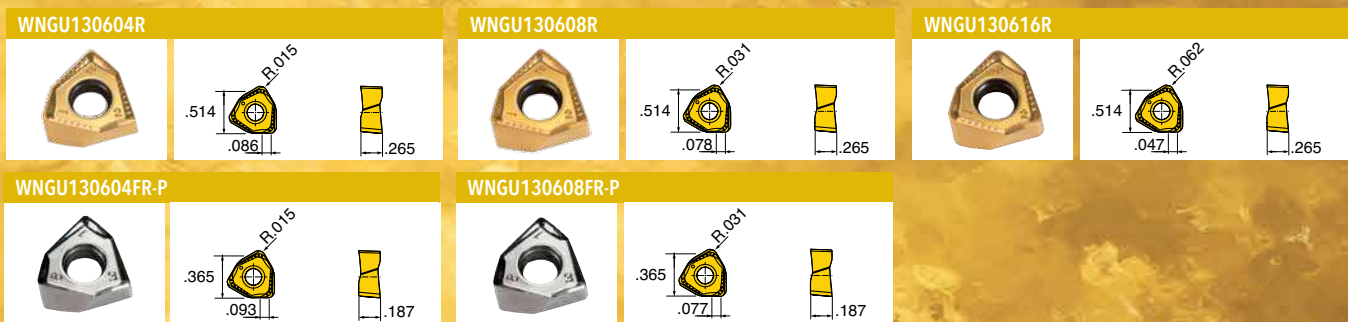

Part Number	Application	Grade	IN2505	IN2510	IN2530	IN2540	IN10K
WNGU130604R	Multi-Purpose - .015" R		●				
WNGU130608R	Multi-Purpose - .031" R		●	●	●	●	
WNGU130616R	Multi-Purpose - .062" R		●	●	●	●	
WNGU130604FR-P	Grd/Pol for Aluminum - .015" R						●
WNGU130608FR-P	Grd/Pol for Aluminum - .031" R						●

LONG EDGE CUTTERS

- Extreme efficiency with most positive geometry in the market.
- Inserts offered with keen hi-temp and durable flat face geometries.
- Internal coolant supply.
- Well suited for Stainless Steel and Hi Temp Alloys.



HIQUAD™ SERIES 25J3P

0 DEGREE LEAD EXT. FLUTE SHELL MILL

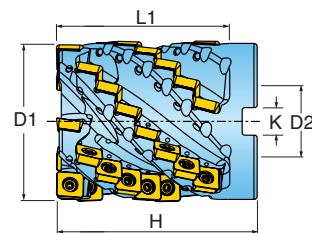
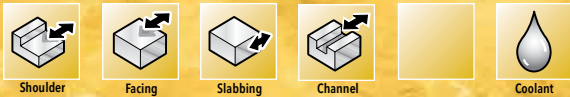

Cutter Number	D1 Effective Diameter	L1 Length of Cut	H Height	D2 Bore Diameter	K Keyway	# of Effective Inserts	# of Total Inserts	Retention Bolt
25J3P-20030D1R00	2.000	2.0	3.00	0.750	0.31	4	20	SD-06-79
25J3P-20030D1R01	2.000	2.0	3.00	0.750	0.31	3	15	SD-06-79
25J3P-30037D4R00	3.000	3.0	3.75	1.250	0.50	5	40	SD-10-54
25J3P-30050D4R10	3.000	4.0	5.00	1.250	0.50	5	55	SD-10-04
25J3P-40050D5R00	4.000	4.0	5.00	1.500	0.62	5	55	SD-12-79

Operating Guidelines on page 93.

HIQUAD™ SERIES 25J3P

0 DEGREE LEAD EXT. FLUTE END MILL

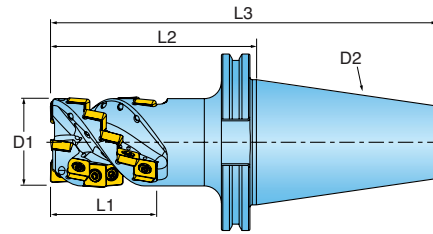
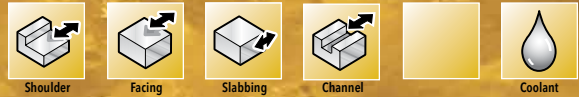

Cutter Number	D1 Effective Diameter	L1 Length of Cut	L2 Ext Length	L3 Overall Length	D2 Adaption	# of Effective Inserts	# of Total Inserts
25J3P-20045D1R00	2.000	2.3	4.50	8.50	ICT #50 V-Flange	3	18
25J3P-20062D1R00	2.000	4.0	6.25	10.25	ICT #50 V-Flange	4	44

Operating Guidelines on page 93.

HIQUAD™ INSERTS

SDMS

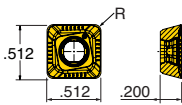

SDES

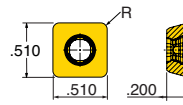

Part Number	Application	R Corner	Indexes	Grade	IN4005	IN4030	IN4035	IN4015
End Station Options								
SDMS130512R-PP	Hi-Temp	R.047	4			X		
SDMS130516R-PP	Hi-Temp	R.062	4		X	X	X	X
SDES130508N-PF	Multi-Purpose Flat Top	R.031	4		X	X	X	X
SDES130516N-PF	Multi-Purpose Flat Top	R.062	4		X	X	X	X
SDES130524N-PF	Multi-Purpose Flat Top	R.093	4		X	X		
SDES130532N-PF	Multi-Purpose Flat Top	R.125	4		X	X		
SDES130564N-PF*	Multi-Purpose Flat Top	R.250	2		X	X		

*Cutter body to be relieved to accommodate large radius.

Side Station Options

SDMS130516R-PP	Hi-Temp	R.062	4		X	X	X	X
SDES130516N-PF	Multi-Purpose Flat Top	R.062	4		X	X	X	X

HIQUAD™ HARDWARE



Insert Screw

SM40-100-R0



Driver Handle

DS-A00T



Insert Driver Blade

DS-T156B



Optional Torque Wrench

DT-35-02



Optional Insert Driver Blade

DS-T15B1

ISOPLUS

90° QUAD EXPANSION

- 8 Positive cutting edges with 90 degree shoulder
- .47" Max depth of cut
- .24" Depth of cut along 90 degree shoulder
- Medium and High Density cutter offerings
- 2.00-8.00 diameter range
- Cutters equipped with coolant through



ISOPLUS SERIES DJ6T, DJ5T

0 DEGREE LEAD FACEMILL WITH 8 INDEXES

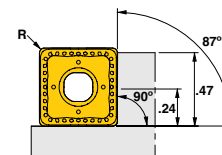
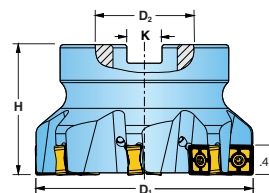

Cutter Number	Nominal Diameter	D1 Overall Diameter	D2 Bore Size	K Keyway	H Height	Number of Inserts	Coolant	Bolt Circle	SHCS	SHCS w/ Coolant Thru*
Medium Density										
DJ6T-20R01	2.000	2.025	0.75	0.31	1.570	5	Yes	-	SD-06-46	SD-06-89
DJ6T-25R01	2.500	2.523	0.75	0.31	1.570	6	Yes	-	SD-06-46	SD-06-89
DJ6T-30R01	3.000	3.021	1.00	0.37	1.750	7	Yes	-	SD-08-46	SD-08-92
DJ6T-40R01	4.000	4.020	1.50	0.62	2.375	8	Yes	-	SD-12-82	SD-12-99
DJ6T-50R01	5.000	5.018	1.50	0.62	2.375	10	Yes	-	SD-12-82	SD-12-99
DJ6T-60R01	6.000	6.018	1.50	0.62	2.375	12	No	-	-	-
DJ6T-80R01	8.000	8.016	2.50	1.00	2.375	14	No	4.00	-	-
High Density										
DJ5T-30R01	3.000	3.021	1.00	0.37	1.750	8	Yes	-	SD-08-46	SD-06-89
DJ5T-40R01	4.000	4.020	1.50	0.62	2.375	10	Yes	-	SD-12-82	SD-12-99
DJ5T-50R01	5.000	5.018	1.50	0.62	2.375	13	Yes	-	SD-12-82	SD-12-99
DJ5T-60R01	6.000	6.018	1.50	0.62	2.375	17	No	-	-	-
DJ5T-80R01	8.000	8.016	2.50	1.00	2.375	21	No	4.00	-	-

Operating Guidelines on page 94.

ISOPLUS INSERTS

SNGU...N (Only corner)

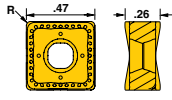

SNGU...TN (Wiper w/R)

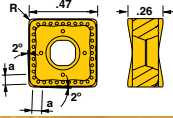
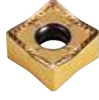

SNGU...ANTN (Wiper w/chamfer)

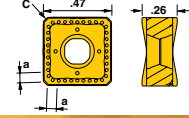

Part Number	Application	R Corner	a Wiper	Grade	IN2510	IN2530	IN2505	IN2540	IN6515	IN71N
SNGU130604N	Positive Geometry	.015R	-		•		•			
SNGU130608N	Positive Geometry	.031R	-							•
SNGU130608TN	Positive Geometry	.031R w/wiper	.047		•	•	•	•	•	
SNGU130616N	Positive Geometry	.062R	-			•	•	•	•	
SNGU1306ANTN	Positive Geometry	45 x .031 w/wiper	.047		•		•	•	•	

ISOPLUS HARDWARE



Insert Screw

SM40-100-R0



Driver

DS-T15T



Optional Torque Wrench

DT-35-02



Bit for Torque Driver

DS-T15B1

OCTOPLUS™

ECONOMY WITH 16 EDGES

- 16 Cutting Edges for all materials
- Anti-Notch geometry diffuses insert notching and part breakout in iron
- SiNi addresses High RPM applications in iron
- Durable Flat Top battles castings at any depth of cut

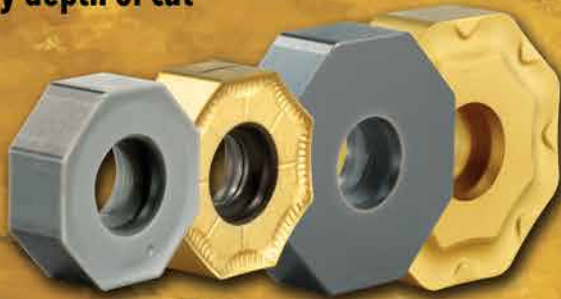

OCTOPLUS™ SERIES ON5H ON6H

45 DEGREE LEAD FACE MILL (SCREW HELD - 5MM INSERT) WITH 16 INDEXES



Lead Angle



Chamfer



Facing



Coolant

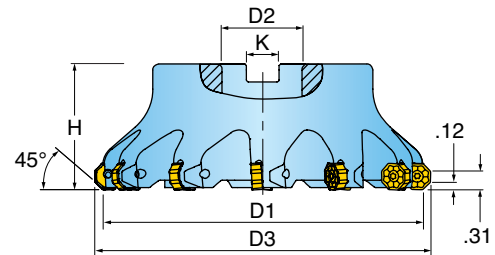

Cutter Number	D1 Effective Diameter	D3 Overall Diameter	Number of Inserts	H Height	D2 Bore Dia.	K Keyway	Coolant
ON6H-15R01	1.500	1.83	4	1.570	0.500	0.250	Yes
ON5H-20R01	2.000	2.33	6	1.570	0.750	0.312	Yes
ON6H-20R01	2.000	2.33	4	1.570	0.750	0.312	Yes
ON6H-25R01	2.500	2.83	6	1.570	0.750	0.312	Yes
ON5H-30R01	3.000	3.33	10	1.750	1.000	0.375	Yes
ON6H-30R01	3.000	3.33	7	1.750	1.000	0.375	Yes
ON5H-40R01	4.000	4.33	12	2.375	1.500	0.625	Yes
ON6H-40R01	4.000	4.33	8	2.375	1.500	0.625	Yes
ON6H-50R01	5.000	5.33	10	2.375	1.500	0.625	Yes
ON5H-60R01	6.000	6.33	18	2.375	1.500	0.625	No
ON6H-60R01	6.000	6.33	12	2.375	1.500	0.625	No



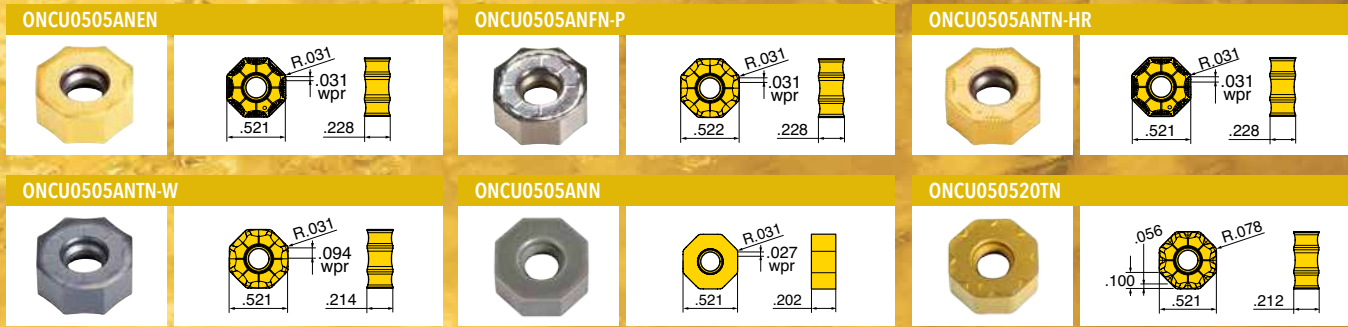

Operating Guidelines on page 94.

OCTOPLUS™ 05 SERIES INSERTS



Part Number	Applications	Grade	IN10K	IN2010	IN2030	IN2035	IN2505	IN6515	IN70N	IN6510
ONCU0505ANN	SiNi for Iron								•	
ONCU050520TN	Anti-Notch						•	•		•
ONCU0505ANEN	Medium, pos. rake angle			•		•	•	•		
ONCU0505ANFN-P	Grd/Pol for Al		•							
ONCU0505ANTN-W	Wiper						•			
ONCU0505ANTN-HR	Positive Geometry			•	•		•			

OCTOPLUS™ HARDWARE

				
	Screw	Driver	Retention Bolt	(Optional) Coolant Bolt
ON6H-15R01	SM40-100-10	DS-T15T	SD-04-86	-
ON5H-20R01	SM40-100-10	DS-T15T	SD-06-46	SD-06-89
ON6H-20R01	SM40-100-10	DS-T15T	SD-06-46	SD-06-89
ON6H-25R01	SM40-100-10	DS-T15T	SD-06-46	SD-06-89
ON5H-30R01	SM40-100-10	DS-T15T	SD-08-46	SD-08-92
ON6H-30R01	SM40-100-10	DS-T15T	SD-08-46	SD-08-92
ON5H-40R01	SM40-100-10	DS-T15T	SD-12-82	SD-12-99
ON6H-40R01	SM40-100-10	DS-T15T	SD-12-82	SD-12-99
ON6H-50R01	SM40-100-10	DS-T15T	SD-12-82	SD-12-99
ON5H-60R01	SM40-100-10	DS-T15T	-	-
ON6H-60R01	SM40-100-10	DS-T15T	-	-

OCTOPLUS™ 05 SERIES INSERTS

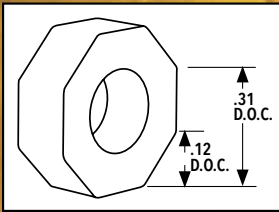

Cutter Series: ON5H/ON6H
Insert Series: ONCU05
1.50-6.00 Dia. Range
.12 DOC - 45 Degree Lead

	Part Number	Hone	Corner	Description
<p>16 x .031" Int. Wiper R.031</p>	ONCU0505ANTN-HR	J	R.031	MULTI-PURPOSE Universal insert geometry with landed edge. Integrated wiper flat for surface finishes between RA32-63. Whether it's steel, iron or titanium, this is an excellent first choice.
<p>Indent .094 Crowned Wiper R.031</p>	ONCU0505ANTN-W	J	R.031	MULTI-PURPOSE WIPER Wiper Insert with 8 indexes (4RH, 4LH) and longer wiper flats. When the advance per revolution does not exceed .094", place one wiper insert in one pocket to improve your surface finish by about 20 points. The indentation on the flank marks the edges that should contact the workpiece. To be married with ONCU0505ANTN-HR.
<p>16 x .031" Int. Wiper R.031</p>	ONCU0505ANEN	A	R.031	KEEN EDGE This keen, high positive chip former is beneficial when machining exotics or managing breakout on the workpiece. Integrated wiper flat produces good surface finishes.
<p>16 x .031" Int. Wiper R.031</p>	ONCU0505ANFN-P	S	R.031	NON-FERROUS Machining of aluminum and non-ferrous metals is the target for this up sharp and polished geometry. Integrated wiper flat produces good surface finishes.
<p>16 x .027" Int. Wiper R.031</p>	NEW! ONCU0505ANN	J	R.031	SiNi This 16 edged silicon nitride insert offers the best productivity when machining iron. Integrated wiper in place for good surface finishes.
<p>Reinforced Edge R.078 .056 .100</p>	NEW! ONCU050520TN	A	R.078	ANTI-NOTCH This unique design puts a keen edge at the corner to diffuse piece part breakout in iron AND adds a reinforced edge to resist notching between .059-.100 DOC. Large corner radius adds strength for roughing applications.

OCTOPLUS™ SERIES OP1N

45 DEGREE LEAD FACE MILL (WEDGE HELD - 9MM INSERT) WITH 16 INDEXES

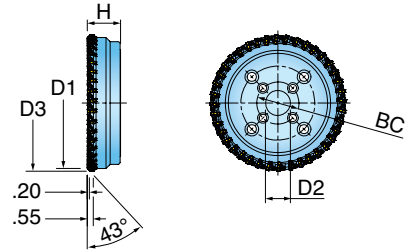

Cutter Number	D1 Effective Diameter	D3 Overall Diameter	Number of Inserts	H Height	D2 Bore Dia.	K Keyway	Bolt Circle
OP1N-30R01	3.000	3.53	8	1.750	1.000	0.375	NA
OP1N-40R01	4.000	4.53	12	2.375	1.500	0.625	NA
OP1N-50R01	5.000	5.53	15	2.375	1.500	0.625	NA
OP1N-60R01	6.000	6.53	19	2.375	1.500	0.625	NA
OP1N-80L01	8.000	8.53	24	2.375	2.500	1.000	4.00
OP1N-80R01	8.000	8.53	24	2.375	2.500	1.000	4.00
OP1N-10L01	10.000	10.53	30	2.375	2.500	1.000	4.00
OP1N-10R01	10.000	10.53	30	2.375	2.500	1.000	4.00
OP1N-12L01	12.000	12.53	38	2.375	2.500	1.000	4.00, 7.00
OP1N-12R01	12.000	12.53	38	2.375	2.500	1.000	4.00, 7.00

Operating Guidelines on page 94.

OCTOPLUS™ HARDWARE



Driver

Wedge

Retention Bolt

Adjusting Screw

OP1N-30R01	DS-H04T	2M0813-01	SD-08-46	SB080-03
OP1N-40R01	DS-H04T	2M0813-01	SD-12-82	SB080-03
OP1N-50R01	DS-H04T	2M0813-01	SD-12-82	SB080-03
OP1N-60R01	DS-H04T	2M0813-01	SD-12-82	SB080-03
OP1N-80L01	DS-H04T	2M0813-01	-	SB080-03
OP1N-80R01	DS-H04T	2M0813-01	-	SB080-03
OP1N-10L01	DS-H04T	2M0813-01	-	SB080-03
OP1N-10R01	DS-H04T	2M0813-01	-	SB080-03
OP1N-12L01	DS-T20T	2M0813-01	-	SB080-03
OP1N-12R01	DS-H04T	2M0813-01	-	SB080-03

OCTOPLUS™ SERIES OP6N

45 DEGREE LEAD FACE MILL (SCREW HELD - 9MM INSERT) WITH 16 INDEXES

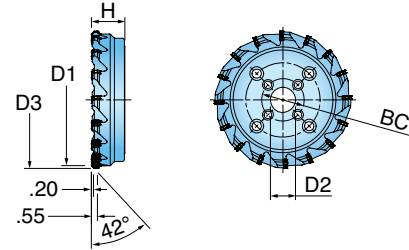

Cutter Number	D1 Effective Diameter	D3 Overall Diameter	Number of Inserts	H Height	D2 Bore Dia.	K Keyway	Bolt Circle	Coolant
OP6N-25R01	2.500	3.04	5	1.570	0.750	0.312	NA	Yes
OP6N-30R01	3.000	3.54	6	1.750	1.000	0.375	NA	Yes
OP6N-40R01	4.000	4.54	7	2.375	1.500	0.625	NA	Yes
OP6N-50R01	5.000	5.54	8	2.375	1.500	0.625	NA	Yes
OP6N-60R01	6.000	6.54	10	2.375	1.500	0.625	NA	No
OP6N-80R01	8.000	8.54	12	2.375	2.500	1.000	4.00	No
OP6N-10R01	10.000	10.54	14	2.375	2.500	1.000	4.00	No
OP6N-12R01	12.000	12.54	16	2.375	2.500	1.000	4.00, 7.00	No

Operating Guidelines on page 94.

OCTOPLUS™ HARDWARE



Driver

Retention Bolt

(Optional) Coolant Bolt

OP6N-25R01	SM50-130-R0	DS-T20T	SD-06-46	SD-06-89
OP6N-30R01	SM50-130-R0	DS-T20T	SD-08-46	SD-08-92
OP6N-40R01	SM50-130-R0	DS-T20T	SD-12-82	SD-12-99
OP6N-50R01	SM50-130-R0	DS-T20T	SD-12-82	SD-12-99
OP6N-60R01	SM50-130-R0	DS-T20T	-	-
OP6N-80R01	SM50-130-R0	DS-T20T	-	-
OP6N-10R01	SM50-130-R0	DS-T20T	-	-
OP6N-12R01	SM50-130-R0	DS-T20T	-	-

OCTOPLUS™ 09 SERIES INSERTS

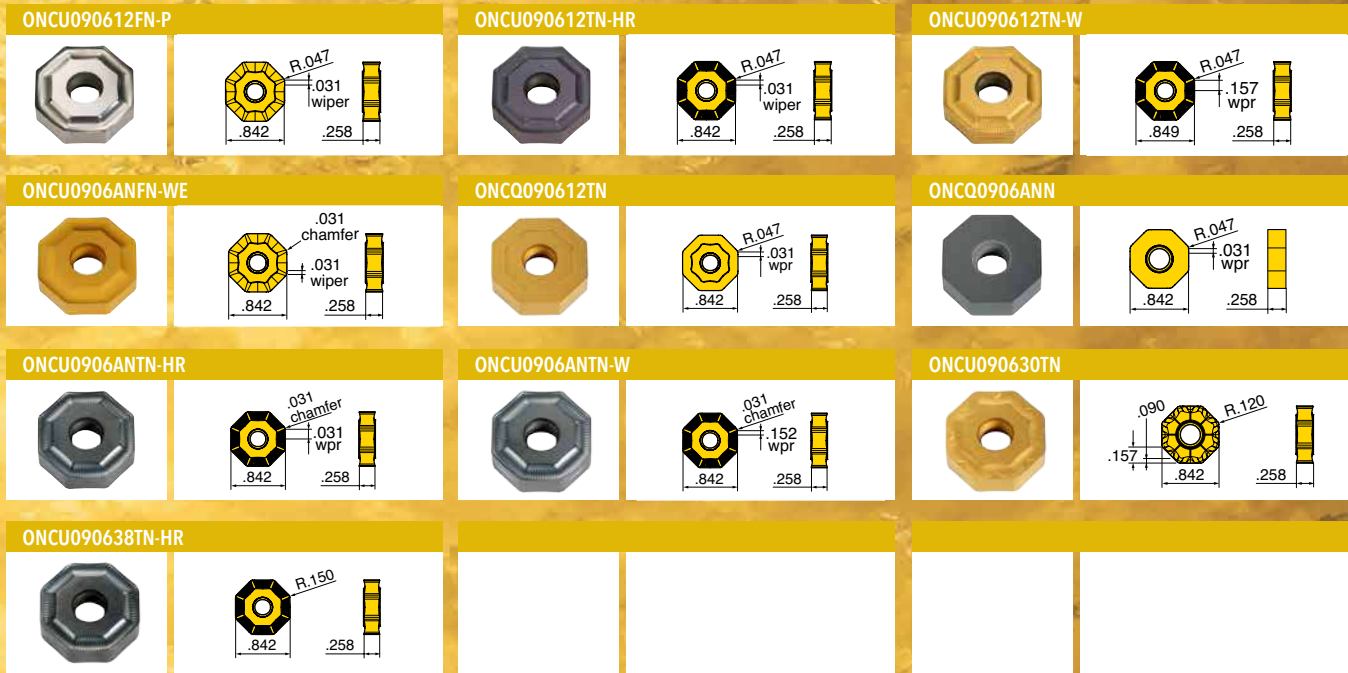

Part Number	Applications	Grade	IN10K	IN2004	IN2030	IN2035	IN2040	IN2505	IN2510	IN6510	IN6515	IN70N
ONCQ0906ANN	SiNi for Iron											X
ONCQ090612TN	Flat Top							X		X	X	
ONCU090630TN	Anti-Notch									X	X	
ONCU090612FN-P	Grd/Pol for Al		X									
ONCU090612TN-W	Wiper							X				
ONCU0906ANTN-W	Wiper								X			
ONCU090612TN-HR	Multi-Purpose				X		X	X				
ONCU0906ANFN-WE	Positive Geometry			X		X			X		X	
ONCU0906ANTN-HR	Pos. w/Land							X	X			

OCTOPLUS™ 09 SERIES INSERTS

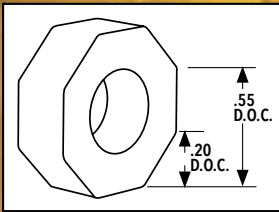

Cutter Series: OP6N RH
 Insert Series: ONC_09
 2.50-12.00 Dia. Range
 .20 DOC
 45 Degree Lead



Cutter Series: OP1N RH&LH
 Insert Series: ONC_09
 3.00-12.00 Dia. Range
 .20 DOC
 45 Degree Lead

	Part Number	Hone	Corner	Description
	ONCU090612TN-HR	J	R.047	MULTI-PURPOSE Universal insert with landed edge for machining steels, iron and hi-temp alloys. Also equipped with an integrated wiper flat to produce surface finishes between RA32-63. First choice for most applications.
	ONCU090612TN-HR	E	R.047	
	ONCU090612TN-W	J	R.047	MULTI-PURPOSE WIPER Wiper Insert with 8 indexes (4RH, 4LH) and longer wiper flats. When the advance per revolution does not exceed .157", place one wiper insert in one pocket to improve your surface finish by about 20 points. The indentation on the flank marks the edges that should contact the workpiece. To be married with ONCU090612TN-HR.
	ONCU090612FN-P	S	R.047	NON-FERROUS Up sharp and polished insert that targets aluminum and non-ferrous materials. Integrated wiper in place for good surface finishes. Also shows good results in bi-metal with grade IN04S.
	NEW! ONCQ090612TN	A	R.047	FLAT TOP Flat Top geometry with landed edge for heavy duty roughing. Integrated wiper in place for good surface finishes. If other positive geometries notch at the DOC, put this strong edge to work.
	NEW! ONCQ0906ANN	J	R.047	SiNi This 16 edged silicon nitride insert offers the best productivity when machining iron. Integrated wiper in place for good surface finishes.

OCTOPLUS™ 09 SERIES INSERTS

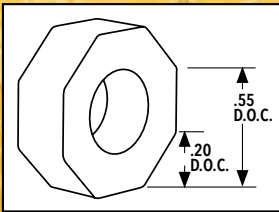

Cutter Series: OP6N RH
 Insert Series: ONC_09
 2.50-12.00 Dia. Range
 .20 DOC
 45 Degree Lead



Cutter Series: OP1N RH&LH
 Insert Series: ONC_09
 3.00-12.00 Dia. Range
 .20 DOC
 45 Degree Lead

	Part Number	Hone	Corner	Description
	NEW! ONCU0906ANTN-HR	J	Faceted	FACETED MULTI-PURPOSE A faceted corner with positive geometry helps avoid breakout on an iron workpiece. The landed edge adds strength.
	NEW! ONCU0906ANTN-W	J	Faceted	FACETED WIPER Wiper Insert with 8 indexes (4RH, 4LH) and longer wiper flats. When the advance per revolution does not exceed .152", place one wiper insert in one pocket to improve your surface finish by about 20 points. The indentation on the flank marks the edges that should contact the workpiece. To be married with ONCU0906ANTN-HR.
	ONCU0906ANFN-WE	A	Faceted	KEEN EDGE This keen, high positive chip former in combination with a faceted corner offers benefits when challenged with workpiece breakout. It also performs well in exotics
	NEW! ONCU090630TN	A	R.120	ANTI-NOTCH This unique design puts a positive edge at the corner to diffuse piece part breakout in iron AND adds a reinforced edge to resist notching between .090-.157 DOC. Large corner radius adds strength for roughing applications.
	NEW! ONCU090638TN-HR	E	R.150	POSITIVE ROUGHER The large corner radius and landed edge make this insert well suited for roughing applications in steel and iron

FORMMASTERTM

HIGH-FEED

HIGH FEED CUTTERS

- Particularly Suitable for High Feed Machining
- Low Cutting Forces
- 6 Cutting Edges for Cost Effective Machining
- Excellent Chip Cvacuation
- Through Coolant Cutter Bodies



FORMMASTERTM SERIES 1DG1H

HIGH FEED ENDMILL WITH 6 INDEXES

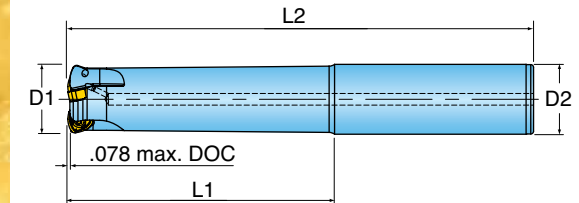

Cutter Number	D1 Nom. Dia.	L1 Extension Length	L2 Overall Length	D2 Shank Size/Style	Number of Inserts	Coolant Thru	Max. Ramp Angle
1DG1H-1202781R01	1.250	2.750	5.00	1.250" Weldon	2	Yes	3.0
1DG1H-12057S9R01	1.250	4.750	8.00	1.250" Cylindrical	2	Yes	3.0
1DG1H-1503386R01	1.500	3.310	6.00	1.500" Weldon	3	Yes	1.7
1DG1H-15073S5R01	1.500	5.727	10.00	1.500" Cylindrical	3	Yes	1.7

Operating Guidelines on page 95.



FORMMASTER[™] SERIES 1DG1H (TOP•ON STYLE)

HIGH-FEED

SERIES 1DG1H (TOP•ON STYLE)

HIGH FEED MODULAR ENDMILL WITH 6 INDEXES



Shoulder



Ramping



Corkscrew



Pocket



Contour



Plunging



Coolant

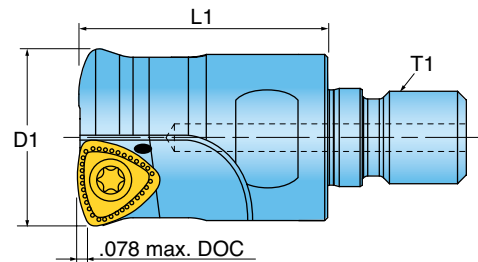

Cutter Number	D1 Nom. Dia.	Number of Inserts	L1 Extension Length	T1 Adaption	Max. Ramp Angle	Wrench Size
1DG1H-12017X8R01	1.250	2	1.75	M16	3	22mm
1DG1H-15017X8R01	1.500	3	1.75	M16	1.75	22mm

Operating Guidelines on page 95.

FORMMASTER[™] SERIES DG6H

HIGH-FEED

HIGH FEED FACEMILL WITH 6 INDEXES

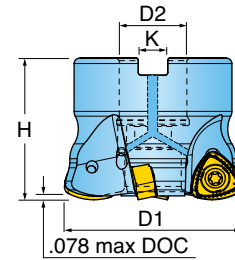

Cutter Number	D1 Effective Diameter	Number of Inserts	H Height	D2 Bore Dia.	K Keyway	Ramp Angle
DG6H-20R01	2.000	3	1.570	0.750	0.312	1.0
DG6H-20R02	2.000	4	1.570	0.750	0.312	1.0
DG6H-20R03	2.000	5	1.570	0.750	0.312	1.0
DG6H-25R01	2.500	4	1.570	0.750	0.312	.5
DG6H-30R01	3.000	5	1.750	1.000	0.375	.5
DG6H-30R02	3.000	5	2.000	1.250	0.500	.5
DG6H-40R01	4.000	6	2.375	1.500	0.625	.4
DG6H-60R01	6.000	8	2.375	1.500	0.625	.2

Operating Guidelines on page 95.

FORMMASTER[®] HIGH-FEED INSERTS

UNEU1205R



Part Number	Application	Grade	IN2530	IN2505	IN2540	IN6530
UNEU1205R	High-Feed - 0.118" R*		•	•	•	•

*Program Radius

FORMMASTER[®] HIGH-FEED HARDWARE



Screw



Driver



Retention Bolt



(Optional) Coolant Bolt

DG6H-20R01	SM40-120-20	DS-T15T	SD-06-46	SD-06-89
DG6H-20R02	SM40-120-20	DS-T15T	SD-06-46	SD-06-89
DG6H-25R01	SM40-120-20	DS-T15T	SD-06-46	SD-06-89
DG6H-30R01	SM40-120-20	DS-T15T	SD-08-46	SD-08-92
DG6H-30R02	SM40-120-20	DS-T15T	SD-10-47	SD-10-99
DG6H-40R01	SM40-120-20	DS-T15T	SD-12-82	SD-12-99
DG6H-60R01	SM40-120-20	DS-T15T	SD-12-82	SD-12-99

HI FEED MINI™

GENERAL MACHINING, DIE & MOLD, AEROSPACE

- Insert Technology provides 4 cutting edges per insert
- Robustly designed insert with exceptionally strong cutting edge
- Premium cutter bodies, with through coolant standard
- Ingersoll technology, designed to deliver economy, strength and performance
- Depth of cut up to .039" (1mm)



HI FEED MINI SERIES 1TG1F

HIGH FEED ENDMILL WITH 4 INDEXES

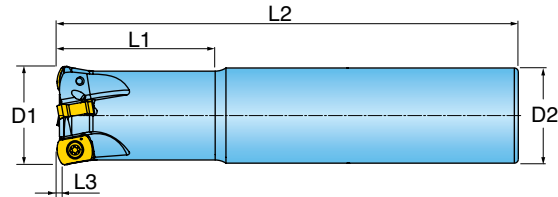

Cutter Number	D1 Nom. Dia.	L1 Extension Length	L2 Overall Length	L3 Max. DOC	D2 Shank Size/Style	Number of Inserts	Ramp Angle
1TG1F-06015ULR01	0.625	1.250	4.00	0.027	15.5mm Cyl	2	1.5
1TG1F-06015S6R01	0.625	1.260	4.00	0.027	.625" Cyl	2	1.5
1TG1F-07017UMR01	0.750	1.500	5.00	0.030	18.5mm Cyl	3	1.4
1TG1F-07017UMR02	0.750	1.500	6.25	0.027	18.5mm Cyl	3	1.4
1TG1F-07022S7R01	0.750	2.000	5.00	0.027	.750" Cyl	3	1.4
1TG1F-07032S7R01	0.750	3.000	6.25	0.027	.750" Cyl	3	1.4
1TG1F-08019UNR01	0.875	1.750	7.75	0.039	21.5mm Cyl	3	1.1
1TG1F-10022T5R01	1.000	2.000	7.00	0.039	25mm Cyl	4	.8
1TG1F-10022S1R01	1.000	2.000	10.00	0.039	1.000" Cyl	4	.8
1TG1F-10022T5R02	1.000	2.000	10.00	0.039	25mm Cyl	4	.8
1TG1F-10032S1R01	1.000	3.000	7.00	0.039	1.000" Cyl	4	.8
1TG1F-1203281R01	1.250	3.000	5.50	0.039	1.250" W	5	.6
1TG1F-12050E2R01	1.250	4.750	8.00	0.039	1.250" W	5	.6
1TG1F-15015E2R01	1.500	N/A	6.00	0.039	1.250" W	6	.5

Operating Guidelines on page 95.



HI•FEED^{MINI} SERIES 1TG1F (TOP•ON STYLE)

HIGH FEED MODULAR ENDMILL WITH 4 INDEXES

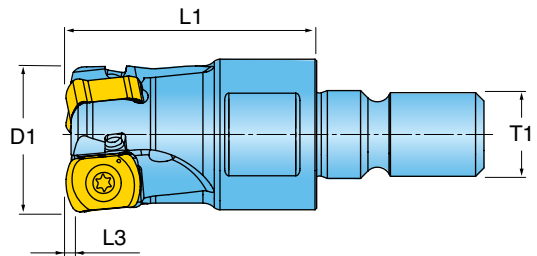

Cutter Number	D1 Nom. Dia.	M Adaption	L1 Extension Length	L3 Max. DOC	Number of Inserts	Wrench Size	Ramp Angle
1TG1F-06010X5R01	0.625	M8	0.98	0.027	2	10mm	.5
1TG1F-07011X6R01	0.750	M10	1.18	0.027	3	15mm	1.4
1TG1F-10013X7R01	1.000	M12	1.37	0.039	4	17mm	.8
1TG1F-12015X8R01	1.250	M16	1.57	0.039	5	22mm	.6
1TG1F-15015X8R10	1.500	M16	1.57	0.039	6	22mm	.5

Operating Guidelines on page 95.

HI-FEED^{MINI} SERIES TG1F

HIGH FEED FACEMILL WITH 4 INDEXES

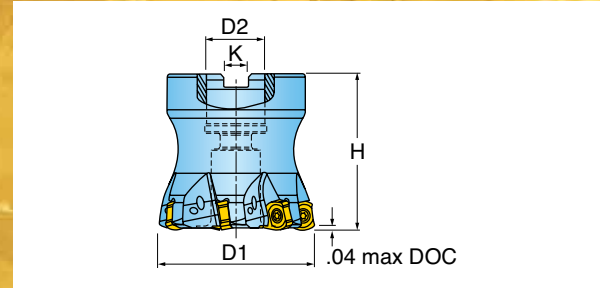

Cutter Number	D1 Eff. Dia.	Number of Inserts	H Height	D2 Bore Dia.	K Keyway	Max. Ramp Angle
TG1F-20R01	2.000	7	1.968	0.750	0.312	.3

Operating Guidelines on page 95.

HI-FEED MINI INSERTS

UNLU0603MOTR

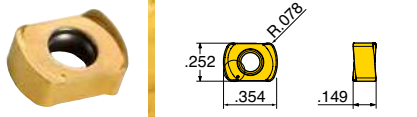

UNLU0603MOTR-ML

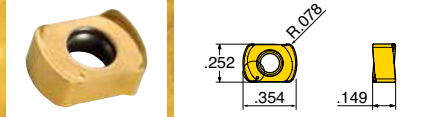

UNLU0603MOTR-MM

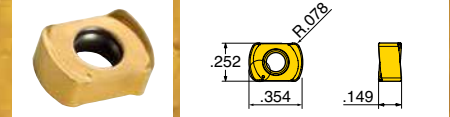

Part Number	Corner	Application	Grade	IN2030	IN2035	IN2505	IN2530	IN6530
UNLU0603MOTR	0.078 R	High-Feed		•	•	•	•	•
UNLU0603MOTR-ML	0.078 R	High-Feed			•	•	•	
UNLU0603MOTR-MM	0.078 R	High-Feed			•	•	•	

M

MM

ML

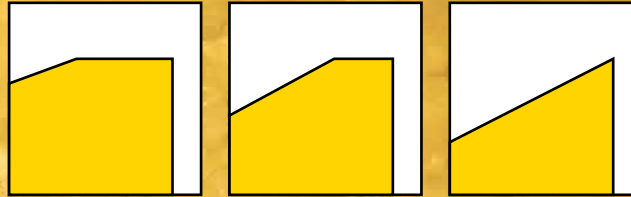

HI-FEED MINI HARDWARE



Screw



Driver

TG1F/1TG1F

SM25-064-00

DS-T08W

NEW QUAD FEED CUTTER 13MM AND 19MM IC INSERT SIZES

- Positive lead angle - High Feed Technology.
- Ultra-strong, super free cutting insert geometries.
- 4 indexes per insert.
- Up to 8 different insert geometry types.
- Application flexibility.
- Premium milling grades.
- Latest post coating treatment technology to ensure long lasting performance.



HIQUAD^F™ SERIES 15M1P

13MM INSERTED CUTTERS, HIGH FEED

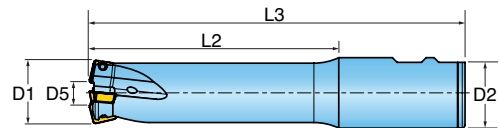
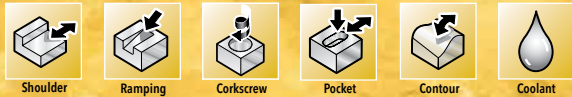

Cutter Number	Nom. Dia.	# of Inserts	L3 OAL	D2 Shank Style	Coolant	SDES1305MDR, SDMS1305MDR-PH, SDES1305MDR-001, SDES130515N-001, SDES130515N, SDMS130515R-PH, SDMS130512R-PP				SDES1305MPR, SDES1305MPR-001			
						D1 Program OD Dia.	D5 Effective Dia.	L2 Ext. Length	Max. Ramp Angle	D1 Program OD Dia.	D5 Effective Dia.	L2 Ext. Length	Max. Ramp Angle
15M1P-1202781R01	1.250	2	5.000	1.25 Weldon	yes	1.250	0.423	2.750	5.6	1.220	0.533	2.735	4.7
15M1P-12047S9R01	1.250	2	8.000	1.25 Cylindrical	yes	1.250	0.423	4.750	5.6	1.220	0.533	4.735	4.7
15M1P-1502786R01	1.500	3	5.410	1.50 Weldon	yes	1.500	0.673	2.750	3.1	1.470	0.784	2.735	2.8
15M1P-1505386R01	1.500	3	8.000	1.50 Weldon	yes	1.500	0.673	5.340	3.1	1.470	0.784	5.325	2.8

Operating Guidelines on page 96.

HIQUAD^F™ SERIES 15M1P (TOP-ON STYLE)

13MM INSERTED CUTTERS, HIGH FEED

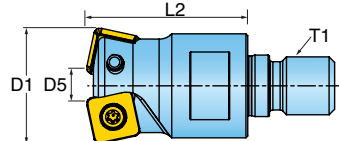
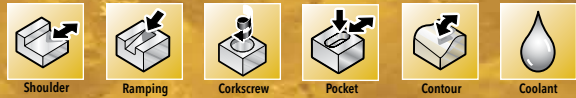

Cutter Number	Nom. Dia.	# of Inserts	T1 Adaption	Coolant	SDES1305MDR, SDMS1305MDR-PH, SDES1305MDR-001, SDES130515N-001, SDES130515N, SDMS130515R-PH, SDMS130512R-PP				SDES1305MPR, SDES1305MPR-001			
					D1 Program OD Dia.	D5 Effective Dia.	L2 Ext. Length	Max. Ramp Angle	D1 Program OD Dia.	D5 Effective Dia.	L2 Ext. Length	Max. Ramp Angle
15M1P-12017X8R01	1.250	2	M16	Yes	1.250	0.423	1.750	5.6	1.220	0.533	1.735	4.7



Operating Guidelines on page 60.

HIQUAD^F™ SERIES 15M1P (TOP-ON STYLE) - METRIC

Cutter Number	Nom. Dia.	# of Inserts	T1 Adaption	Coolant	SDES1305MDR, SDMS1305MDR-PH, SDES1305MDR-001, SDES130515N-001, SDES130515N, SDMS130515R-PH, SDMS130512R-PP				SDES1305MPR, SDES1305MPR-001			
					D1 Program OD Dia.	D5 Effective Dia.	L2 Ext. Length	Max. Ramp Angle	D1 Program OD Dia.	D5 Effective Dia.	L2 Ext. Length	Max. Ramp Angle
15M1P032043X8R00	32mm	2	M16	Yes	32mm	11mm	43mm	5.0	31.23mm	13.8mm	42.63mm	4.5
15M1P035043X8R00	35mm	2	M16	Yes	35mm	14.2mm	43mm	4.0	34.23mm	16.81mm	42.63mm	3.5
15M1P040043X8R00	40mm	2	M16	Yes	40mm	19mm	43mm	2.7	39.23mm	21.8mm	1.678mm	2.5

Operating Guidelines on page 96.

HIQUAD^F™ ENDMILL HARDWARE

Cutter Number			
	Screw	Driver	Driver Bit
15M1P-1202781R01	SM40-100-R0	DS-A00T	BLD T15/S7
15M1P-1204759R01	SM40-100-R0	DS-A00T	BLD T15/S7
15M1P-1502786R01	SM40-100-R0	DS-A00T	BLD T15/S7
15M1P-1505386R01	SM40-100-R0	DS-A00T	BLD T15/S7

HIQUAD^F™ ENDMILL HARDWARE - METRIC

		
Screw	Driver	Driver Bit
SM40-100-R0	DS-A00T	BLD T15/S7

HIQUAD[®] SERIES 5M_P

13MM INSERTED CUTTERS, HIGH FEED

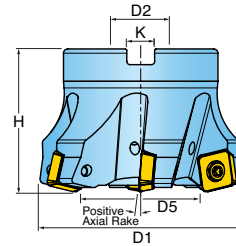

Cutter Number	Nom. Dia.	# of Inserts	D2 Bore Dia.	K Keyway	Coolant	SDES1305MDR, SDMS1305MDR-PH, SDES1305MDR-001, SDES130515N-001, SDES130515N, SDMS130515R-PH, SDMS130512R-PP				SDES1305MPR, SDES1305MPR-001			
						D1 Program OD Dia.	D5 Effective Dia.	H Height	Max. Ramp Angle	D1 Program OD Dia.	D5 Effective Dia.	H Height	Max. Ramp Angle
5M5P-20R01	2.000	5	0.750	0.312	yes	2.000	1.170	2.000	1.7	1.970	1.281	1.985	1.5
5M6P-20R01	2.000	4	0.750	0.312	yes	2.000	1.170	2.000	1.7	1.970	1.281	1.985	1.5
5M5P-25R01	2.500	6	0.750	0.312	yes	2.500	1.670	2.000	1.1	2.470	1.781	1.985	1.1
5M6P-25R01	2.500	5	0.750	0.312	yes	2.500	1.670	2.000	1.1	2.470	1.781	1.985	1.1
5M5P-30R01	3.000	8	1.000	0.375	yes	3.000	2.170	2.000	0.9	2.970	2.280	1.985	0.8
5M6P-30R01	3.000	6	1.000	0.375	yes	3.000	2.170	2.000	0.9	2.970	2.280	1.985	0.8
5M5P-30R02	3.000	8	1.250	0.500	yes	3.000	2.170	2.000	0.9	2.970	2.280	1.985	0.8
5M6P-30R02	3.000	6	1.250	0.500	yes	3.000	2.170	2.000	0.9	2.970	2.280	1.985	0.8
5M5P-40R01	4.000	10	1.500	0.625	yes	4.000	3.170	2.500	0.6	3.970	3.280	2.485	0.6
5M6P-40R01	4.000	8	1.500	0.625	yes	4.000	3.170	2.500	0.6	3.970	3.280	2.485	0.6
5M5P-50R01	5.000	11	1.500	0.625	yes	5.000	4.170	2.500	0.4	4.970	4.280	2.485	0.4
5M6P-50R01	5.000	9	1.500	0.625	yes	5.000	4.170	2.500	0.4	4.970	4.280	2.485	0.4

Operating Guidelines on page 96.

HIQUAD[®] SERIES 5M_P - METRIC

Cutter Number	Nom. Dia.	# of Inserts	D2 Bore Dia.	K Keyway	Coolant	SDES1305MDR, SDMS1305MDR-PH, SDES1305MDR-001, SDES130515N-001, SDES130515N, SDMS130515R-PH, SDMS130512R-PP				SDES1305MPR, SDES1305MPR-001			
						D1 Program OD Dia.	D5 Effective Dia.	H Height	Max. Ramp Angle	D1 Program OD Dia.	D5 Effective Dia.	H Height	Max. Ramp Angle
5M5P050R00	50mm	5	22mm	10.4mm	Yes	50mm	28.92mm	50mm	1.5	49.237mm	31.74mm	49.627mm	1.5
5M5P052R00	52mm	5	22mm	10.4mm	Yes	52mm	30.92mm	50mm	1.5	51.233mm	33.736mm	49.627mm	1.5
5M5P063R00	63mm	6	22mm	10.4mm	Yes	63mm	41.9mm	50mm	1	62.23mm	44.72mm	49.63mm	1
5M5P066R00	66mm	6	27mm	12.4mm	Yes	66mm	44.89mm	50mm	1	65.23mm	47.72mm	49.63mm	1
5M5P100R00	100mm	9	32mm	14.4mm	Yes	100mm	78.91mm	60mm	0.5	99.24mm	81.74mm	59.62mm	0.5
5M6P052R00	52mm	4	22mm	10.4mm	Yes	52mm	30.92mm	50mm	1.5	51.233mm	33.736mm	49.627mm	1.5
5M6P063R00	63mm	5	22mm	10.4mm	Yes	63mm	41.9mm	50mm	1	62.23mm	44.72mm	49.63mm	1
5M6P080R00	80mm	6	27mm	12.4mm	Yes	80mm	58.91mm	50mm	0.5	79.25mm	61.73mm	49.63mm	1
5M6P100R00	100mm	7	32mm	14.4mm	Yes	100mm	78.91mm	60mm	0.5	99.24mm	81.74mm	59.62mm	0.5

Operating Guidelines on page 96.

HIQUAD^F™ SERIES 5G_M



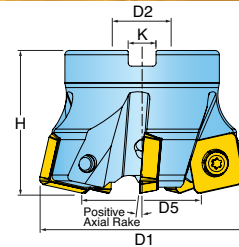

19MM INSERTED CUTTERS, HIGH FEED







Cutter Number	Nom. Dia.	# of Inserts	D2 Bore Dia.	K Keyway	Coolant	SDES1906MDR, SDMS1906MDR-PH, SDES190620N, SDES190620N-001, SDMS190620R-PH				SDES1906MPR, SDES1906MPR-001			
						D1 Program OD Dia.	D5 Effective Dia.	H Height	Max. Ramp Angle	D1 Program OD Dia.	D5 Effective Dia.	H Height	Max. Ramp Angle
5G5M-30R01	3.000	6	1.00	0.375	yes	3.000	1.766	2.000	1.6	2.961	1.903	1.981	1.2
5G6M-30R01	3.000	5	1.00	0.375	no	3.000	1.755	2.000	1.6	2.961	1.894	1.981	1.2
5G5M-40R01	4.000	8	1.50	0.625	yes	4.000	2.769	2.500	1.0	3.961	2.906	2.481	0.8
5G6M-40R01	4.000	6	1.50	0.625	no	4.000	2.755	2.500	1.0	3.961	2.894	2.481	0.8
5G5M-50R01	5.000	9	1.50	0.625	yes	5.000	3.759	2.500	1.7	4.961	3.897	2.481	0.6
5G6M-50R01	5.000	7	1.50	0.625	no	5.000	3.755	2.500	0.7	4.961	3.894	2.481	0.6
5G5M-60R01	6.000	10	1.50	0.625	no	6.000	4.757	2.500	0.6	5.961	4.896	2.481	0.4
5G6M-60R01	6.000	8	1.50	0.625	no	6.000	4.755	2.500	0.6	5.961	4.894	2.481	0.4

Operating Guidelines on page 96.

HIQUAD^F™ FACEMILL HARDWARE

Cutter Number					
	Screw	Driver	Driver Bit	Retention Bolt	Coolant Thru Retention Bolt
5G5M-30R01	SM60-135-R0	DS-T25T	n/a	SD-08-47	SD08-C9
5G6M-30R01	SM60-135-R0	DS-T25T	n/a	SD-08-47	-
5G5M-40R01	SM60-135-R0	DS-T25T	n/a	SD-12-82	SD12-99
5G6M-40R01	SM60-135-R0	DS-T25T	n/a	SD-12-82	-
5G5M-50R01	SM60-135-R0	DS-T25T	n/a	SD-12-82	SD12-99
5G6M-50R01	SM60-135-R0	DS-T25T	n/a	SD-12-82	-
5G5M-60R01	SM60-135-R0	DS-T25T	n/a	SD-12-82	-
5G6M-60R01	SM60-135-R0	DS-T25T	n/a	SD-12-82	-
5M5P-20R01	SM40-100-R0	DS-A00T	BLD T15/S7	SD-06-48	SD06-A6
5M6P-20R01	SM40-100-R0	DS-A00T	BLD T15/S7	SD-06-48	SD06-A6
5M6P-25R01	SM40-100-R0	DS-A00T	BLD T15/S7	SD-06-48	SD06-A6
5M5P-25R01	SM40-100-R0	DS-A00T	BLD T15/S7	SD-06-48	SD06-A6
5M5P-30R01	SM40-100-R0	DS-A00T	BLD T15/S7	SD-08-47	SD08-C9
5M6P-30R01	SM40-100-R0	DS-A00T	BLD T15/S7	SD-08-47	SD08-C9
5M5P-30R02	SM40-100-R0	DS-A00T	BLD T15/S7	SD-10-47	SD10-99
5M6P-30R02	SM40-100-R0	DS-A00T	BLD T15/S7	SD-10-47	SD10-99
5M5P-40R01	SM40-100-R0	DS-A00T	BLD T15/S7	SD-12-82	SD12-99
5M6P-40R01	SM40-100-R0	DS-A00T	BLD T15/S7	SD-12-82	SD12-99
5M5P-50R01	SM40-100-R0	DS-A00T	BLD T15/S7	SD-12-82	SD12-99
5M6P-50R01	SM40-100-R0	DS-A00T	BLD T15/S7	SD-12-82	SD12-99

Cutter Number	 Screw	 Driver	 Driver Bit	 Retention Bolt
5M5P050R00	SM40-100-R0	DS-A00T	BLDT15/S7	SD06-74
5M5P052R00	SM40-100-R0	DS-A00T	BLDT15/S7	SD06-74
5M5P063R00	SM40-100-R0	DS-A00T	BLDT15/S7	SD06-74
5M5P066R00	SM40-100-R0	DS-A00T	BLDT15/S7	SD07-40
5M5P100R00	SM40-100-R0	DS-A00T	BLDT15/S7	SD10-89
5M6P052R00	SM40-100-R0	DS-A00T	BLDT15/S7	SD06-74
5M6P063R00	SM40-100-R0	DS-A00T	BLDT15/S7	SD06-74
5M6P080R00	SM40-100-R0	DS-A00T	BLDT15/S7	SD08-A4
5M6P100R00	SM40-100-R0	DS-A00T	BLDT15/S7	SD10-89

SDMS130515R-PH  	SDMS1305MDR-PH  	SDES1305MDR  
SDES130515N  	SDES130515N-001  	SDES1305MDR-001  
SDES1305MPR-001  	SDES1305MPR  	

Insert Number	Applications	Max DOC	Program Corner Radius	Grade	IN2505	IN2530	IN4005	IN4030	IN4035
SDES1305MDR	Hi-Feed, Flat Face / Wiper - Facets	.078 (2mm)	.125		•	•			
SDES130515N	Hi-Feed, Flat Face / Corner Radius	.078 (2mm)	.125		•	•			
SDES130515N-001	Hi-Feed, Precision Flat Face / Corner Radius	.078 (2mm)	.125		•	•			
SDMS1305MDR-PH	Hi-Feed, Pos Precision / Wiper - Facets	.078 (2mm)	.125		•	•	•	•	•
SDMS130515R-PH	Hi-Feed, Pos Precision / Corner Radius	.078 (2mm)	.125		•	•	•	•	•
SDES1305MDR-001	Hi-Feed, Precision Flat Face / Wiper - Facets	.078 (2mm)	.125		•	•			
SDES1305MPR	Hi-Feed, Heavy Duty - Standard	.088 (2.24mm)	.140		•	•	•		•
SDES1305MPR-001	Hi-Feed, Heavy Duty - Precision	.088 (2.24mm)	.140		•	•	•	•	•

*Note: Please refer to the New Product Announcement for detailed programming information.

HIQUAD^F™ 19MM INSERTS

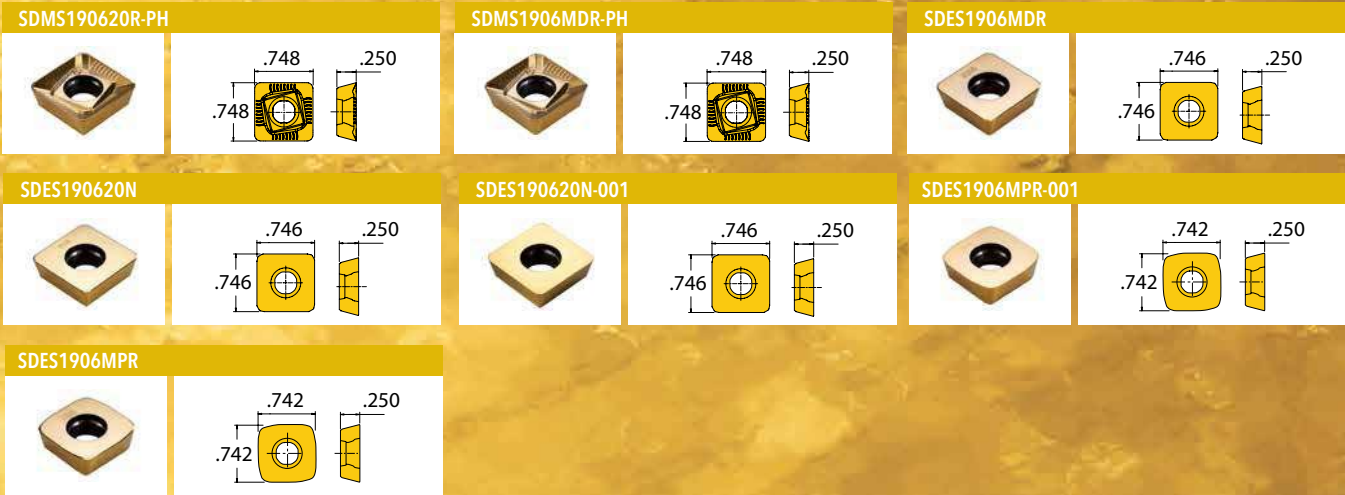

Insert Number	Applications	Max DOC	Program Corner Radius	Grade	IN2505	IN2530	IN4005	IN4030	IN4035
SDES1906MDR	Hi-Feed, Flat Face / Wiper - Facets	.118 (3mm)	.180		•	•			
SDES190620N	Hi-Feed, Flat Face / Corner Radius	.118 (3mm)	.180		•	•			
SDES190620N-001	Hi-Feed, Precision Flat Face / Corner Radius	.118 (3mm)	.180		•	•			
SDMS1906MDR-PH	Hi-Feed, Pos Precision / Wiper - Facets	.118 (3mm)	.180		•	•	•	•	•
SDMS190620R-PH	Hi-Feed, Pos Precision / Corner Radius	.118 (3mm)	.180		•	•	•	•	•
SDES1906MPR	Hi-Feed, Heavy Duty - Standard	.147 (3.7mm)	.212		•	•	•		•
SDES1906MPR-001	Hi-Feed, Heavy Duty - Precision	.147 (3.7mm)	.212		•	•	•	•	•

*Note: Please refer to the New Product Announcement for detailed programming information.

PLUNGING CUTTERS

- Excels in general plunge roughing & long reach plunge applications.
- Inserts offered with clean shearing Hi-Temp Alloy geometry and strong Flat Top geometry.
- Internal coolant supply.



HIQUAD™ SERIES QHU

BACKDRAFT PLUNGE CUTTERS



Plunge



Coolant

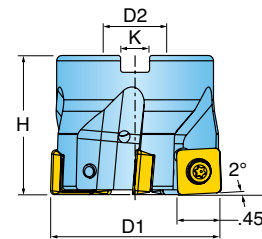

Cutter Number	D1 Effective Diameter	# of Inserts	H Height	D2 Bore Diameter	K Keyway	Retention Bolt	Optional Coolant Bolt
QHU-20015D1R01	2.000	5	1.570	0.750	0.31	SD-06-46	SD-06-89
QHU-20015D1R02	2.000	4	1.570	0.750	0.31	SD-06-46	SD-06-89
QHU-25015D1R01	2.500	5	1.570	0.750	0.31	SD-06-46	SD-06-89
QHU-30017D3R01	3.000	7	1.750	1.000	0.38	SD-08-46	SD-08-92
QHU-30017D3R02	3.000	5	1.750	1.000	0.38	SD-08-46	SD-08-92
QHU-40023D4R01	4.000	9	2.375	1.500	0.63	SD-12-82	SD-12-99
QHU-40023D4R02	4.000	7	2.375	1.500	0.63	SD-12-82	SD-12-99

Operating Guidelines on page 96.

HIQUAD™ INSERTS

SDMS

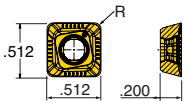

SDES

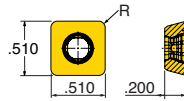

Part Number	Application	R Corner	Indexes	Grade			
				IN4005	IN4030	IN4035	IN4015
SDMS130512R-PP	Hi-Temp	R.047	4		•		
SDMS130516R-PP	Hi-Temp	R.062	4	•	•	•	•
SDES130508N-PF	Multi-Purpose Flat Top	R.031	4	•	•	•	•
SDES130516N-PF	Multi-Purpose Flat Top	R.062	4	•	•	•	•
SDES130524N-PF	Multi-Purpose Flat Top	R.093	4	•	•		
SDES130532N-PF	Multi-Purpose Flat Top	R.125	4	•	•		

*Cutter body to be relieved to accommodate large radius.

HIQUAD™ HARDWARE



Insert Screw

SM40-100-R0



Driver Handle

DS-A00T



Insert Driver Blade

DS-T156B



Optional Torque Wrench

DT-35-02



Optional Insert Driver Blade

DS-T15B1

ISOPLUS

HI FEED MILL WITH 8 INDEXES

- Value with 8 strong cutting edges (4 + 4).
- Near net shape flexibility with .065 axial depth of cut capability.
- Chip evacuation via coolant through the tool capability.
- Deck surface finish capability with .050 integrated wiper flat.
- Clearance angles for corkscrew and ramping applications.
- Utilizes the same insert used on our 45° lead (series DN6H) and 15° lead (series DL6H) cutters.



ISOPLUS SERIES DD6H

HIGH FEED FACE MILL WITH 8 INDEXES

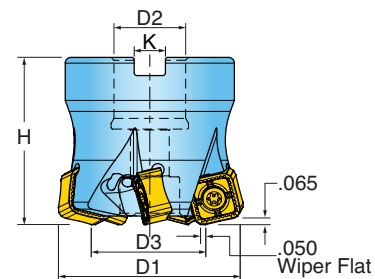

Cutter Number	D1 Effective Diameter	D3 Inner Diameter	D2 Bore Diameter	H Height	# of Effective Inserts	Keyway	Ramp Angle
DD6H-20R01	2.000	1.252	0.750	1.650	5	0.312	1.2
DD6H-25R01	2.500	1.752	.75	1.650	6	0.312	.80
DD6H-30R01	3.000	2.252	1.000	1.750	7	0.375	.66
DD6H-40R01	4.000	3.252	1.500	2.375	9	0.625	.45
DD6H-50R01	5.000	4.252	1.500	2.375	11	0.625	.20
DD6H-60R01	6.000	5.252	1.500	2.000	13	0.625	.10

Operating Guidelines on page 97.

ISOPLUS INSERT

SNGU1205ENN

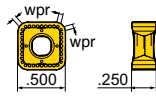

Part Number	Program Corner Radius	Application	Grade	IN2035	IN2505	IN2510	IN2530	IN2540	IN6515
SNGU1205ENN	R.155	Multi-Purpose		•	•	•	•	•	•

ISOPLUS HARDWARE



Insert Screw



Driver Handle



Insert Driver Blade



Retention Bolt



Coolant Bolt (Optional)

DD6H-20R01	SM40-100-R0	DS-A00T	DS-T156B	SD-06-47	SD-06-89
DD6H-25R01	SM40-100-R0	DS-A00T	DS-T156B	SD-06-46	SD-06-89
DD6H-30R01	SM40-100-R0	DS-A00T	DS-T156B	SD-08-46	SD-08-92
DD6H-40R01	SM40-100-R0	DS-A00T	DS-T156B	SD-12-82	SD-12-99
DD6H-50R01	SM40-100-R0	DS-A00T	DS-T156B	SD-12-82	SD-12-99
DD6H-60R01	SM40-100-R0	DS-A00T	DS-T156B	-	-

DIPOSOTETRA™

4D 90

90 DEGREE LINE WITH 4 CUTTING EDGES

- High Density Cutter Maximizes Productivity
- High Positive Cutting Edges - Smooth Cutting Action
- Thick Insert Design - Stable and Reliable Performance
- Ground Edge & Top Polished Insert Available for Aluminum Machining



DIPOSOTETRA™ SERIES 1TJ1Q

4D 90

0 DEGREE LEAD ENDMILL WITH 4 INDEXES

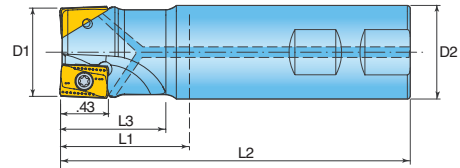

Cutter Number	D1 Effective Diameter	L1 Extension Length	L2 Overall Length	L3 Projection Length	D2 Shank Size/Style	# of Inserts	Ramp Angle
1TJ1Q-1001784R01	1.000	1.75	3.75	1.75	.750 W	2	1.09
1TJ1Q-1001780R01	1.000	1.75	4.00	1.55	1.00 W	2	1.09
1TJ1Q-1003780R01	1.000	3.75	6.00	3.55	1.00 W	2	1.09
1TJ1Q-1201784R01	1.250	1.75	3.75	1.75	.750 W	3	.73
1TJ1Q-1202281R01	1.250	2.25	4.50	2.22	1.25 W	3	.73
1TJ1Q-1204281R01	1.250	4.25	6.50	4.22	1.25 W	3	.73
1TJ1Q-1502281R01	1.500	2.25	4.50	2.25	1.25 W	4	.58
1TJ1Q-2002281R01	2.000	2.25	4.50	2.22	1.25 W	5	.40

Operating Guidelines on page 97.



DIPOSOTETRA™ SERIES 1TJ1Q (TOP•ON STYLE)

0 DEGREE LEAD ENDMILL WITH 4 INDEXES

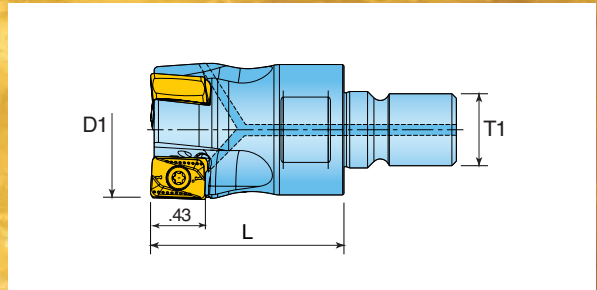

Cutter Number	D1 Effective Diameter	T1 Adaption	L1 Extension Length	Number of Inserts	Wrench Size	Ramp Angle
1TJ1Q-10015X7R01	1.000	M12	1.50	2	17mm	1.09
1TJ1Q-12017X8R01	1.250	M16	1.75	3	22mm	.73
1TJ1Q-15017X8R01	1.500	M16	1.75	4	22mm	.58

Operating Guidelines on page 97.

DIPOSOTETRA™ SERIES TJ5Q, TJ6Q
4D 50

0 DEGREE LEAD FACEMILL WITH 4 INDEXES

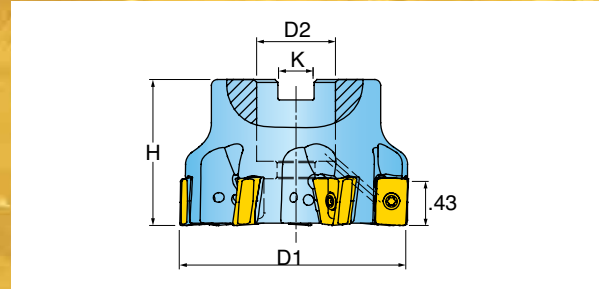

Cutter Number	D1 Effective Diameter	# of Inserts	H Height	D2 Bore Diameter	Retention Bolt	Optional Coolant Bolt	K Keyway	Ramp Angle
TJ5Q-20R01	2.000	6	1.570	0.75	SD-06-46	SD-06-89	0.31	.40
TJ6Q-20R01	2.000	3	1.570	0.75	SD-06-46	SD-06-89	0.31	.40
TJ6Q-25R01	2.500	6	1.570	0.75	SD-06-46	SD-06-89	0.31	.30
TJ5Q-30R01	3.000	9	1.750	1.00	SD-08-46	SD-08-92	0.38	.25
TJ6Q-30R01	3.000	7	1.750	1.00	SD-08-46	SD-08-92	0.38	.25
TJ5Q-40R01	4.000	11	2.375	1.50	SD-12-82	SD-12-99	0.62	.18
TJ6Q-40R01	4.000	7	2.375	1.50	SD-12-82	SD-12-99	0.62	.18

Operating Guidelines on page 97.

DIPOSOTETRA™ INSERTS

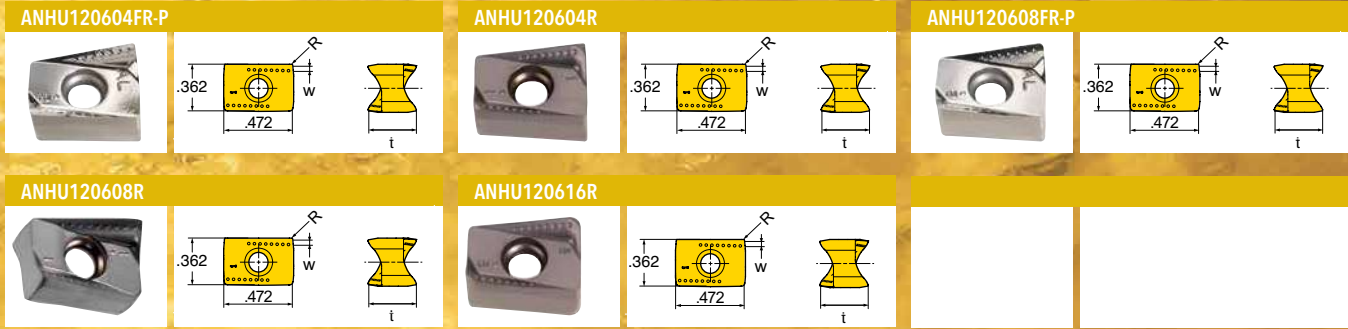

Part Number	Application	R Corner	w Wiper	t Thick.	Grate	IN10K	IN2505	IN2510	IN2530	IN2540
ANHU120604R	Multi-Purpose	.015" R	0.060	0.338			•			
ANHU120608R	Multi-Purpose	.031" R	0.043	0.338			•	•	•	•
ANHU120616R	Multi-Purpose	.062" R	0.028	0.338			•		•	
ANHU120604FR-P	Ground/Polished for Alum.	.015" R	0.060	0.338		•				
ANHU120608FR-P	Ground/Polished for Alum.	.031" R	0.047	0.338		•				

DIPOSOTETRA™ HARDWARE

		
	Screw	
ANHU12	SM35-088-10	DS-T10T

DIPOSOTETRA™

4D 90

DOUBLE YOUR CUTTING EDGES FROM 2 TO 4!

- Two Sided Insert Adds Value by Doubling You Cutting Edges!
- Thick and Robust Insert Adds Durability to Demanding Cutting Conditions
- Double Positive Geometry Benefits Machining Efficiency and Slices Super Alloy Msterials
- Integrated Wiper Flat Produces Exceptional Surface Finishes
- Coolant Through the Tool Offered
- Various Corner Radii Offered



DIPOSOTETRA™ SERIES 1TJ1N

4D 90

0 DEGREE LEAD ENDMILL WITH 4 INDEXES

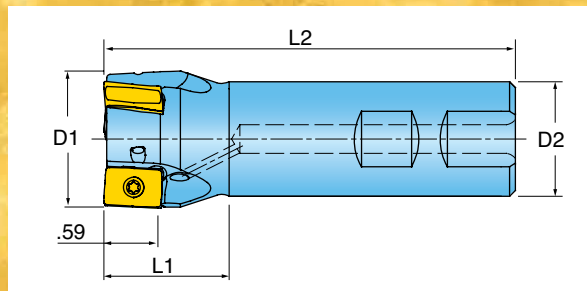

Cutter Number	D1 Nominal Diameter	L1 Extension Length	L2 Overall Length	D2 Shank Size/Style	Number of Inserts	Ramp Angle
1TJ1N-1202281R01	1.250	2.25	4.50	1.250" Weldon	2	1.2
1TJ1N-1204281R01	1.250	4.25	6.50	1.250" Weldon	2	1.2
1TJ1N-1206281R01	1.250	6.25	8.50	1.250" Weldon	2	1.2
1TJ1N-1502281R01	1.500	2.25	4.50	1.250" Weldon	3	1.1
1TJ1N-1504281R01	1.500	4.25	6.50	1.250" Weldon	3	1.1
1TJ1N-2002281R01	2.000	2.25	4.50	1.250" Weldon	4	1.0

Operating Guidelines on page 97.



DIPOSOTETRA™ SERIES 1TJ1N (TOP•ON STYLE)

0 DEGREE LEAD ENDMILL WITH 4 INDEXES

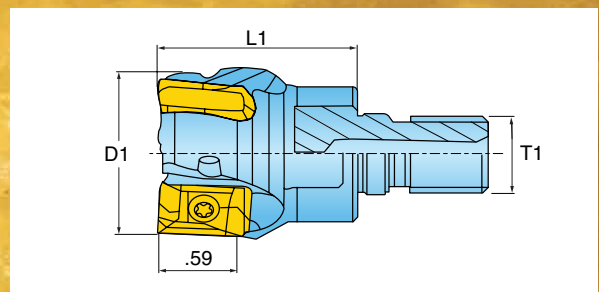

Cutter Number	D1 Nom. Dia.	T1 Adaption	L1 Extension Length	Number of Inserts	Wrench Size	Ramp Angle
1TJ1N-12015X8R01	1.250	M16	1.50	2	22mm	1.2
1TJ1N-15015X8R01	1.500	M16	1.50	3	22mm	1.1

Operating Guidelines on page 97.

DIPOSOTETRA™ SERIES TJ5N, TJ6N

0 DEGREE LEAD FACEMILL WITH 4 INDEXES

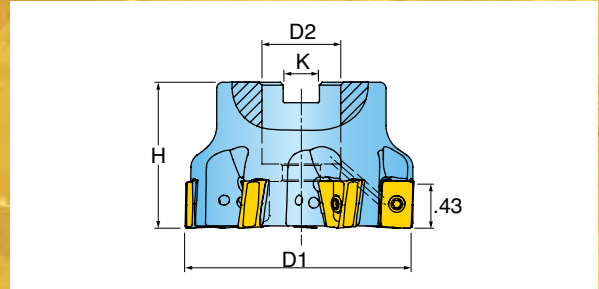

Cutter Number	D1 Nominal Diameter	Number of Inserts	H Height	D2 Bore Dia.	K Keyway	Bolt Circle Diameter	Ramp Angle
TJ5N-20R01	2.000	4	1.570	0.750	0.312	NA	1.0
TJ6N-20R01	2.000	3	1.570	0.750	0.312	NA	1.0
TJ5N-25R01	2.500	5	1.750	1.000	0.375	NA	.60
TJ5N-30R01	3.000	7	1.750	1.000	0.375	NA	.50
TJ6N-30R01	3.000	5	1.750	1.000	0.375	NA	.50
TJ5N-40R01	4.000	8	2.000	1.500	0.625	NA	.35
TJ6N-40R01	4.000	5	2.000	1.500	0.625	NA	.35
TJ5N-50R01	5.000	10	2.000	1.500	0.625	NA	.25
TJ6N-50R01	5.000	7	2.000	1.500	0.625	NA	.25
TJ5N-60R01	6.000	11	2.480	1.500	0.625	NA	.15
TJ6N-60R01	6.000	8	2.480	1.500	0.625	NA	.15
TJ5N-80R01	8.000	14	2.480	2.500	1.000	4.00	.05

Operating Guidelines on page 97.

DIPOSOTETRA™ INSERTS



Part Number	Applications	Corner	Grade	IN10K	IN2510	IN2530	IN2505	IN2540	IN6515
ANHU160704FR-P	Ground/Polished for Alum.	0.015" R		•					
ANHU160704R	Multi-Purpose	0.015" R				•			
ANHU160708FR	Hi-Temp/Ti	0.031" R				•			
ANHU160708FR-P	Ground/Polished for Alum.	0.031" R		•					
ANHU160708R	Multi-Purpose	0.031" R			•	•	•	•	•
ANHU160716R	Multi-Purpose	0.062" R			•	•	•	•	
ZNHU160708R	Chip Splitters	0.031" R				•	•		

DIPOSOTETRA™ HARDWARE

				
	Screw	Retention Bolt	Retention Bolt	(Optional) Coolant Bolt
1TJ1N	SM40-120-20	DS-T15T	-	-
TJ5N-20R01	SM40-120-20	DS-T15T	SD-06-46	SD-06-89
TJ6N-20R01	SM40-120-20	DS-T15T	SD-06-46	SD-06-89
TJ5N-25R01	SM40-120-20	DS-T15T	SD-08-46	SD-08-92
TJ5N-30R01	SM40-120-20	DS-T15T	-	-
TJ6N-30R01	SM40-120-20	DS-T15T	-	-
TJ5N-40R01	SM40-120-20	DS-T15T	-	-
TJ6N-40R01	SM40-120-20	DS-T15T	-	-
TJ5N-50R01	SM40-120-20	DS-T15T	-	-
TJ6N-50R01	SM40-120-20	DS-T15T	-	-
TJ5N-60R01	SM40-120-20	DS-T15T	-	-
TJ6N-60R01	SM40-120-20	DS-T15T	-	-
TJ5N-80R01	SM40-120-20	DS-T15T	-	-

DIPOSOTETRA™

4D 45

HIGH SHEAR 45° LEAD WITH 4 CUTTING EDGES

- Combination of High Positive Insert with 45° Entry Angle: Extremely Smooth and Silent Cutting Action
- High Helix 4 Corner Insert
- Excellent Surface Finish with Wide Wiper Flat
- Maximum .31" Depth of Cut



DIPOSOTETRA™ SERIES TN1N

4D 90

45 DEGREE LEAD FACEMILL WITH 4 INDEXES

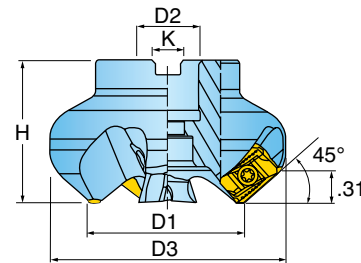

Cutter Number	D1 Nominal Diameter	D3 Overall Diameter	Number of Inserts	D2 Bore Dia.	H Height	K Keyway
TN1N-20R01	2.000	2.68	4	0.750	1.750	0.312
TN1N-30R01	3.000	3.68	5	1.000	1.750	0.375
TN1N-30R02	3.000	3.68	7	1.000	1.750	0.375
TN1N-40R01	4.000	4.67	6	1.500	2.375	0.625
TN1N-40R02	4.000	4.67	8	1.500	2.375	0.625
TN1N-60R01	6.000	6.67	10	1.500	2.375	0.625

Operating Guidelines on page 97.



DIPOSOTETRA™ INSERTS
4D 90

ANHU1607ANR

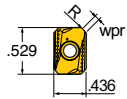

Part Number	Applications	Wiper	R Corner	Grade	IN2510	IN2530	IN2540
ANHU1607ANR	Multi-Purpose	.062	0.015" R		•	•	•

DIPOSOTETRA™ HARDWARE
4D 90



Screw

SM40-120-20



DS-T15T

FORMMASTER SHEAR™

ULTRA-SHEAR HIGH PERFORMANCE BUTTON CUTTER

- Robust thick insert design.
- Larger, stronger insert geometries promote longer tool life.
- Strong clamping screw for demanding applications.
- Anti-rotating system, inserts will not rotate during machining.
- Ultra reliable machining performance at high feed rates.
- Premium milling grades to cut all materials.
- Latest post coating treatment technology to ensure long lasting performance.



FORMMASTER SHEAR™ SERIES 15B1B

12MM IC BUTTON CUTTERS

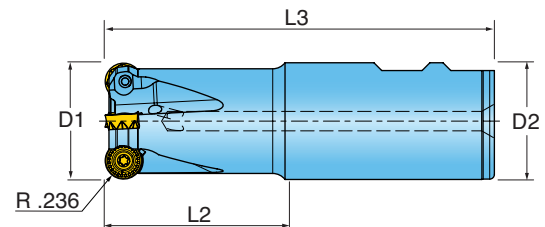
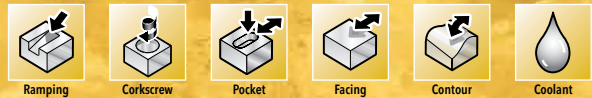

Cutter Number	D1 Nominal Diameter	L2 Extension Length	Number of Inserts	L3 Overall Length	D2 Shank Size/Style	Coolant Through	Max. Ramp Angle	Insert Series
15B1B02404480R00	24mm(.945)	1.750	2	4.000	1.00 Weldon	Yes	2.9	RJLT12
15B1B-1001780R01	1.000	1.750	2	4.500	1.00 Weldon	Yes	3.3	RJLT12
15B1B-1002051R01	1.000	2.000	2	6.000	1.000 Cyl.	Yes	3.3	RJLT12
15B1B-1202781R01	1.250	2.750	3	5.000	1.25 Weldon	Yes	5.0	RJLT12
15B1B-1202059R01	1.250	2.000	3	6.000	1.25 Cyl.	Yes	5.0	RJLT12
15B1B-1502386R01	1.500	2.340	4	5.000	1.500 Weldon	Yes	6.8	RJLT12
15B1B-1502055R01	1.500	2.000	4	6.000	1.500 Cyl.	Yes	6.8	RJLT12

Operating Guidelines on page 98.



FORMMASTER[®]SHEAR™ SERIES 15B1B (TOP-ON STYLE)

12MM IC BUTTON CUTTERS

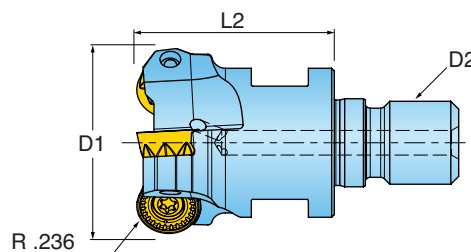
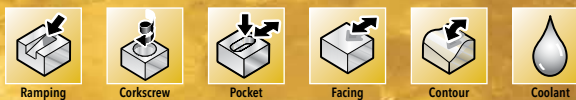

Cutter Number	D1 Nominal Diameter	L2 Extension Length	D2 Thread Size	Number of Inserts	Coolant Through	Max. Ramp Angle	Insert Series	Wrench Size
15B1B024044X7R00	24mm(.945)	1.500	M12	2	Yes	2.9	RJLT12	17mm
15B1B-10015X7R01	1.000	1.500	M12	2	Yes	3.3	RJLT12	17mm
15B1B-12015X8R01	1.250	1.500	M16	3	Yes	5.0	RJLT12	22mm
15B1B-15015X8R01	1.500	1.500	M16	3	Yes	6.8	RJLT12	22mm

Operating Guidelines on page 98.

FORMMASTER[®]SHEAR™ SERIES 1A7_

12MM AND 16MM IC BUTTON CUTTERS

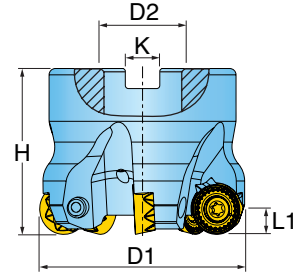
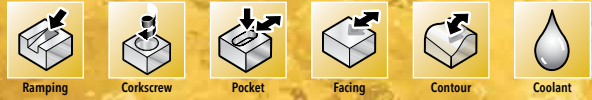

Cutter Number	D1 Nominal Diameter	D2 Bore Dia.	L1 Cut Length	H Height	Number of Insert	K Keyway	Coolant Through	Max. Ramp Angle	Insert Series
1A7H-20R01	2.000	0.750	0.236	1.570	5	0.312	Yes	6	RJLT12
1A7H-25R01	2.500	0.750	0.236	1.570	5	0.312	Yes	4	RJLT12
1A7H-30R01	3.000	1.000	0.236	1.750	6	0.375	Yes	3	RJLT12
1A7H-40R01	4.000	1.500	0.236	2.500	7	0.625	Yes	2	RJLT12
1A7H-50R01	5.000	1.500	0.236	2.500	8	0.625	No	1.75	RJLT12
1A7H-60R01	6.000	1.500	0.236	2.500	9	0.625	No	1.5	RJLT12
1A7K-20R01	2.000	0.750	0.315	1.570	4	0.312	Yes	9	RJLT16
1A7K-25R01	2.500	0.750	0.315	1.570	5	0.312	Yes	7	RJLT16
1A7K-30R01	3.000	1.000	0.315	1.750	5	0.375	Yes	5	RJLT16
1A7K-40R01	4.000	1.500	0.315	2.500	7	0.625	Yes	3.75	RJLT16
1A7K-50R01	5.000	1.500	0.315	2.500	7	0.625	No	2.75	RJLT16
1A7K-60R01	6.000	1.500	0.315	2.500	7	0.625	No	2	RJLT16

Operating Guidelines on page 98.

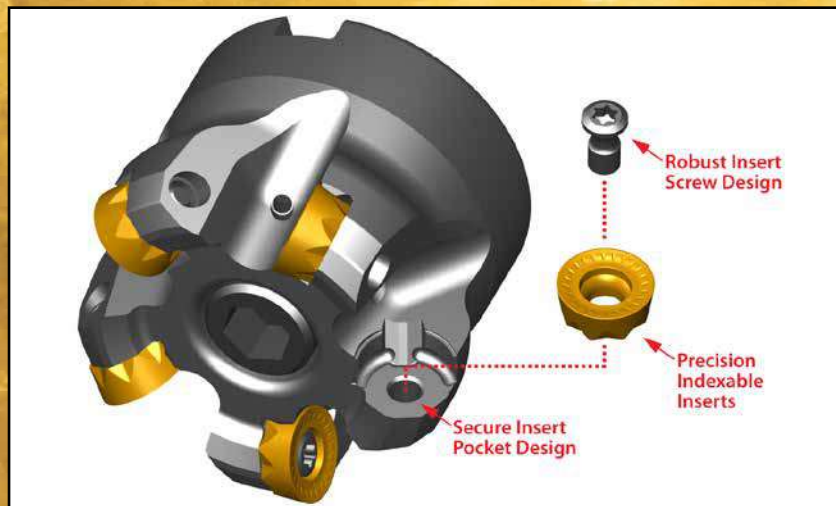



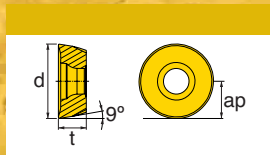
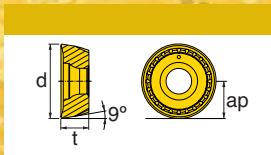

FORMMASTER^{SHEAR}™ INSERTS



Insert Number	Description	d	t	Grade	IN1030	IN6530	IN2530	IN2540	IN2505	IN055
RJLT1204MON	Precision, Pos - 6.000 mm R	12mm	.189		•	•	•		•	
RJLT1204MOTN	Standard, Pos - 6.000 mm R	12mm	.189			•	•	•	•	
RJLW1204MOTN	Heavy Duty, Flt - 6.000 mm R	12mm	.189				•	•	•	
RJET1204MOFN	Grd/Pol for Al - 6.000 mm R	12mm	.189							•
RJLT1605MON	Precision, Pos - 8.000 mm R	16mm	.240			•	•		•	
RJLT1605MOTN	Standard, Pos - 8.000 mm R	16mm	.240		•	•	•	•	•	
RJLW1605MOTN	Heavy Duty, Flt - 8.000 mm R	16mm	.240			•		•	•	
RJET1605MOFN	Grd/Pol for Al - 8.000 mm R	16mm	.240							•

FORMMASTER^{SHEAR}™ HARDWARE

Cutter Number	Insert Series					
		Screw	Driver Bit	Driver Bit	Retention Bolt	Retention Bolt
1A7H-20R01	RJLT12	SM40-093-20	DS-A00T	BLD T15/S7	SD06-46	SD-06-89
1A7H-25R01	RJLT12	SM40-093-20	DS-A00T	BLD T15/S7	SD06-46	SD-06-89
1A7H-30R01	RJLT12	SM40-093-20	DS-A00T	BLD T15/S7	SD08-46	SD-08-92
1A7H-40R01	RJLT12	SM40-093-20	DS-A00T	BLD T15/S7	SD-12-82	SD-12-99
1A7H-50R01	RJLT12	SM40-093-20	DS-A00T	BLD T15/S7	SD-12-82	n/a
1A7H-60R01	RJLT12	SM40-093-20	DS-A00T	BLD T15/S7	SD-12-82	n/a
1A7K-20R01	RJLT16	SM50-113-20	DS-A00T	BLD T20/S7	SD06-46	SD-06-89
1A7K-25R01	RJLT16	SM50-113-20	DS-A00T	BLD T20/S7	SD06-46	SD-06-89
1A7K-30R01	RJLT16	SM50-113-20	DS-A00T	BLD T20/S7	SD08-46	SD-08-92
1A7K-40R01	RJLT16	SM50-113-20	DS-A00T	BLD T20/S7	SD-12-82	SD-12-99
1A7K-50R01	RJLT16	SM50-113-20	DS-A00T	BLD T20/S7	SD-12-82	n/a
1A7K-60R01	RJLT16	SM50-113-20	DS-A00T	BLD T20/S7	SD-12-82	n/a
15B1B02404480R00	RJLT12	SM40-093-20	DS-A00T	BLD T15/S7	n/a	n/a
15B1B-1001780R01	RJLT12	SM40-093-20	DS-A00T	BLD T15/S7	n/a	n/a
15B1B-1002051R01	RJLT12	SM40-093-20	DS-A00T	BLD T15/S7	n/a	n/a
15B1B-1202781R01	RJLT12	SM40-093-20	DS-A00T	BLD T15/S7	n/a	n/a
15B1B-1202059R01	RJLT12	SM40-093-20	DS-A00T	BLD T15/S7	n/a	n/a
15B1B-1502386R01	RJLT12	SM40-093-20	DS-A00T	BLD T15/S7	n/a	n/a
15B1B-1502055R01	RJLT12	SM40-093-20	DS-A00T	BLD T15/S7	n/a	n/a
15B1B024044X7R00	RJLT12	SM40-093-20	DS-A00T	BLD T15/S7	n/a	n/a
15B1B-10015X7R01	RJLT12	SM40-093-20	DS-A00T	BLD T15/S7	n/a	n/a
15B1B-12015X8R01	RJLT12	SM40-093-20	DS-A00T	BLD T15/S7	n/a	n/a
15B1B-15015X8R01	RJLT12	SM40-093-20	DS-A00T	BLD T15/S7	n/a	n/a

ECONOMICAL DOUBLE SIDED INSERT FOR MOLD & DIE

- Anti-Rotation Insert Clamping System
- Two Different Double Sided Insert Designs, Round & Serrated
- Free Cutting Geometry for All Materials
- Serrated Style Insert for Extended Reach Applications Provides Increased Stability
- Though the Tool Coolant, Delivered to the Cutting Edge



FORMMASTER[®] PROFILE SERIES 1DE1H

BUTTON ENDMILL WITH 8-16 INDEXES

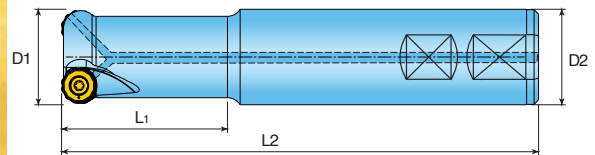

Cutter Number	D1 Nominal Diameter	L1 Extension Length	Number of Inserts	L2 Overall Length	D2 Shank Size/Style
1DE1H-1202781R01	1.250	2.750	3	5.000	1.250 Weldon
1DE1H-1202259R01	1.250	2.250	3	6.000	1.250 Cylindrical
1DE1H-1202059R01	1.250	2.000	3	9.000	1.250 Cylindrical
1DE1H-1502786R01	1.500	2.750	4	5.410	1.500 Weldon
1DE1H-1502255R01	1.500	2.250	4	6.000	1.500 Cylindrical
1DE1H-1502055R01	1.500	2.000	4	9.000	1.500 Cylindrical



FORMMASTER[®] PROFILE SERIES 1DE1H (TOP-ON STYLE)

BUTTON ENDMILL WITH 8-16 INDEXES

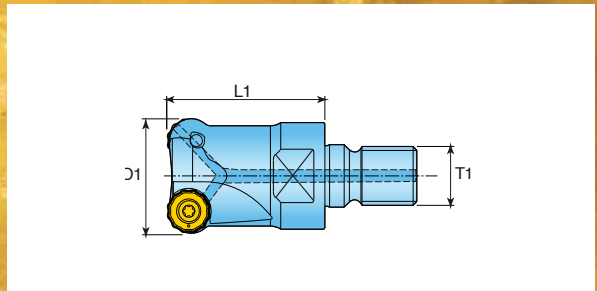

Cutter Number	D1 Nom. Dia.	L1 Extension Length	T1 Thread Size	Number of Inserts
1DE1H-12015X8R01	1.250	1.500	M16	3
1DE1H-15015X8R01	1.500	1.500	M16	4

Operating Guidelines on page 98.

BUTTON FACEMILL WITH 8-16 INDEXES

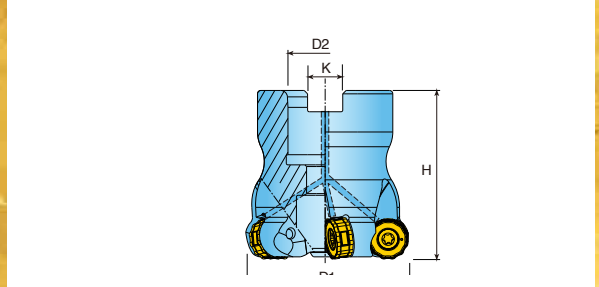

Cutter Number	D1 Nominal Diameter	Number of Inserts	L1 Max DOC	H Height	D2 Bore Diameter	K Keyway
DE6H-20R01	2.000	5	.236	1.750	0.750	0.312
DE6H-25R01	2.500	6	.236	1.750	0.750	0.312
DE6H-30R01	3.000	7	.236	1.750	1.000	0.375

Operating Guidelines on page 98.

FORMMASTER[®] PROFILE INSERTS

RNLU1205MON-M

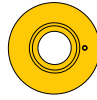
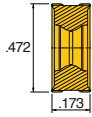

RNLU1205MON-S

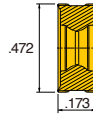

Part Number	Applications	Grade								
			IN6530	IN2530	IN2505					
RNLU1205MON-M*	Standard - 6.000 mm R		•	•	•					
RNLU1205MON-S**	Serrated - 6.000 mm R		•	•	•					

*16 Indexes (Achieved with DOC .070" or less.)

**8 Indexes

FORMMASTER[®] PROFILE HARDWARE



Screw



Driver

1DE1H / DE6H

SM40-110-00

DS-T15T



FINISH BALL™ SERIES 12A9, 12A5

BALL NOSE ENDMILL



Ramping



Corkscrew



Pocket



Contour



STEEL

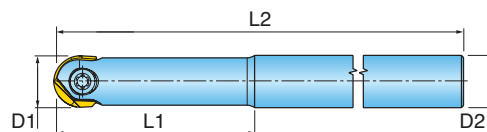

Cutter Number	D1 Effective Diameter	D2 Shank Size/Style	L1 Extension	L2 Overall Length	Effective Cutting Edge	Insert Series
12A9F-03017S4R01	0.375	.500" Cylindrical	1.85	6.00	2	09
12A9H-05019S4R01	0.500	.500" Cylindrical	1.92	7.00	2	12
12A9K-06015S6R01	0.625	.625" Cylindrical	1.58	8.00	2	15
12A9M-07018S7R01	0.750	.750" Cylindrical	1.85	8.00	2	19
12A9R-10018S1R01	1.000	1.000" Cylindrical	1.81	8.00	2	25
12A9S-12030S9R01	1.250	1.250" Cylindrical	3.03	11.81	2	31

CARBIDE

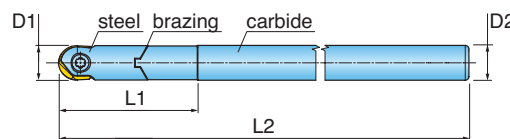

Cutter Number	D1 Effective Diameter	D2 Shank Size/Style	L1 Extension	L2 Overall Length	Effective Cutting Edges	Insert Series
12A5F-03015S8R01	0.375	.375" Cylindrical	1.50	6.00	2	09
12A5H-05015S4R02	0.500	.500" Cylindrical	1.50	4.00	2	12
12A5H-05015S4R01	0.500	.500" Cylindrical	1.50	7.00	2	12
12A5K-06018S6R02	0.625	.625" Cylindrical	1.88	4.00	2	15
12A5K-06018S6R01	0.625	.625" Cylindrical	1.88	7.00	2	15
12A5M-07022S7R02	0.750	.750" Cylindrical	2.25	4.00	2	19
12A5M-07022S7R01	0.750	.750" Cylindrical	2.25	7.50	2	19

BALL NOSE CUTTING SYSTEM FOR DIE & MOLD COUNTOUR MILLING

- Ultra Stable Clamping System and Excellent Repeatability
- Through the Tool Coolant, Delivered to the Cutting Edge (Top•On)
- Premium Ground Cutter Bodies
- Die & Mold, Aero Space and General Purpose
- End Mill, Top-On (Modular) and Solid Carbide (Brazed Shanks)



FINISH•BALL™ PROFILE SERIES 12A9 (TOP•ON STYLE)

BALL NOSE ENDMILL



Ramping

Corkscrew

Pocket

Contour

Coolant

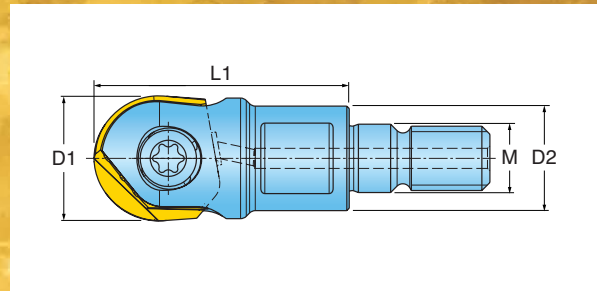

Cutter Number	D1 Effective Diameter	D2 Flange Diameter	T1 Thread Size	L1 Extension	Effective Cutting Edges	Wrench Size	Insert Series
12A9F-03011X5R01	.375	.510	M8	1.00	2	10mm	09
12A9H-05011X5R01	.500	.510	M8	1.00	2	10mm	12
12A9K-06015X5R01	.625	.510	M8	1.25	2	10mm	15
12A9M-07016X6R01	.750	.710	M10	1.25	2	15mm	19
12A9M-07021X7R01	.750	.830	M12	1.50	2	17mm	25
12A9R-10023X7R01	1.000	.975	M12	1.50	2	17mm	31
12A9R-10023X7R02	1.000	.820	M12	1.50	2		
12A9S-12063X8R01	1.250	1.140	M16	2.50	2		

Operating Guidelines on page 99.

FINISH BALL™ SERIES 12A8

PROFILE

BALL NOSE, TAPER STEEL CUTTER BODIES



Corkscrew

Pocket

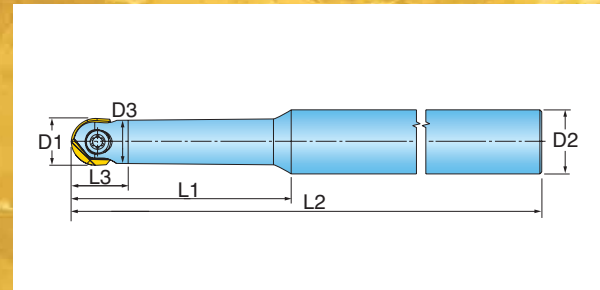

Contour

Coolant



12A8F-03013S4R01	0.375	0.500	.34	1.35	3.50	.63	2	09
12A8F-03018S4R01	0.375	0.500	.34	1.88	6.00	.63	2	09
12A8H-05025S4R01	0.500	0.625	.41	2.50	6.00	.75	2	12
12A8M-07035S7R01	0.750	1.000	.67	3.50	7.50	1.00	2	19

Operating Guidelines on page 99.

HARDWARE	  		
	Screw	Driver	
12A9F-03017S4R01	SM30-083-B1	DS-TP10S	-
12A9H-05019S4R01	SM40-106-B1	DS-TP15S	-
12A9K-06015S6R01	SM50-139-B1	-	DS-T20T
12A9M-07018S7R01	SM60-167-B1	-	DS-T25T
12A9R-10018S1R01	SM70-210-B1	-	DS-T25T
12A9S-12030S9R01	SM80-250-B1	-	DS-T30T
12A5F-03015S8R01	SM30-083-B1	DS-TP10S	-
12A5H-05015S4R02	SM40-106-B1	DS-TP15S	-
12A5H-05015S4R01	SM40-106-B1	DS-TP15S	-
12A5K-06018S6R02	SM50-139-B1	-	DS-T20T
12A5K-06018S6R01	SM50-139-B1	-	DS-T20T
12A5M-07022S7R02	SM60-167-B1	-	DS-T25T
12A5M-07022S7R01	SM60-167-B1	-	DS-T25T
12A8F-03013S4R01	SM30-083-B1	DS-TP10S	-
12A8F-03018S4R01	SM30-083-B1	DS-TP10S	-
12A8H-05025S4R01	SM40-106-B1	DS-TP15S	-
12A8M-07035S7R01	SM60-167-B1	-	DS-T25T
12A9F-03011X5R01	SM30-083-B1	DS-TP10S	-
12A9H-05011X5R01	SM40-106-B1	DS-TP15S	-
12A9K-06015X5R01	SM50-139-B1	-	DS-T20T
12A9M-07016X6R01	SM60-167-B1	-	DS-T25T
12A9R-07021X7R01	SM60-167-B1	-	DS-T25T
12A9S-10023X7R01	SM70-210-B1	-	DS-T25T
12A9R-10023X7R02	SM70-210-B1	-	DS-T25T

FINISH-BALL™ INSERTS

NQHG



GQHG



Eff. Dia.	Part Number	Applications	R Corner	Grade	IN2005	IN2006	IN05S		
0.375	NQHG090200R-FM	Ball Nose, coolant through	0.188		•	•			
0.500	NQHG120300R-FM	Ball Nose, coolant through	0.250		•	•			
0.625	NQHG150400R-FM	Ball Nose, coolant through	0.312		•	•			
0.750	NQHG190500R-FM	Ball Nose, coolant through	0.375		•	•			
1.000	NQHG250600R-FM	Ball Nose, coolant through	0.500		•	•			
1.250	NQHG310700R-FM	Ball Nose, coolant through	0.625		•	•			
0.375	NQHG090200R-SM	Ball Nose, coolant through	0.188		•	•	•		
0.500	NQHG120300R-SM	Ball Nose, coolant through	0.250		•	•	•		
0.625	NQHG150400R-SM	Ball Nose, coolant through	0.312		•	•			
0.750	NQHG190500R-SM	Ball Nose, coolant through	0.375		•	•	•		
1.000	NQHG250600R-SM	Ball Nose, coolant through	0.500		•	•	•		
1.250	NQHG310700R-SM	Ball Nose, coolant through	0.625		•	•			
0.375	GQHG090208R01	Backdraft Blade, coolant through	0.031		•	•			
0.500	GQHG120308R01	Backdraft Blade, coolant through	0.031		•	•			
0.500	GQHG120316R01	Backdraft Blade, coolant through	0.062		•	•			
0.625	GQHG150408R01	Backdraft Blade, coolant through	0.031		•	•			
0.625	GQHG150416R01	Backdraft Blade, coolant through	0.062		•	•			
0.750	GQHG190508R01	Backdraft Blade, coolant through	0.031		•	•			
0.750	GQHG190516R01	Backdraft Blade, coolant through	0.062		•	•			
0.750	GQHG190532R01	Backdraft Blade, coolant through	0.125		•	•			
1.000	GQHG250608R01	Backdraft Blade, coolant through	0.031		•	•			
1.000	GQHG250616R01	Backdraft Blade, coolant through	0.062		•	•			
1.000	GQHG250632R01	Backdraft Blade, coolant through	0.125		•	•			

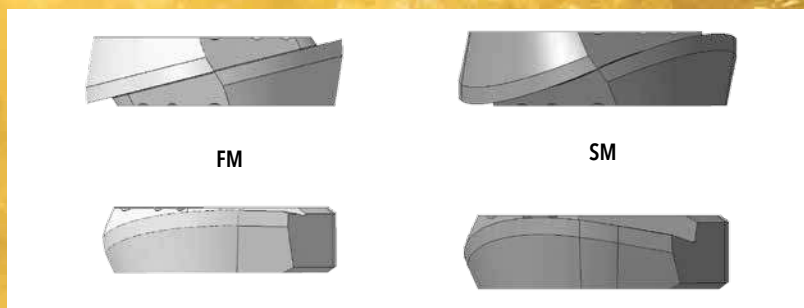

ROUGH BALL FOR TRIPLE FEED RATES!

- 3 Flute Design Enables Increased Feed Rates
- Unique Double-Sided Insert with 2 Cutting Edges
- Highly Stable Cutting Performance with Exceptionally Strong Cutting Edges
- Coolant Through Provides Excellent Chip Evacuation



PROTRIO SERIES 2TW7K

BALL NOSE ENDMILL, 3 FLUTES

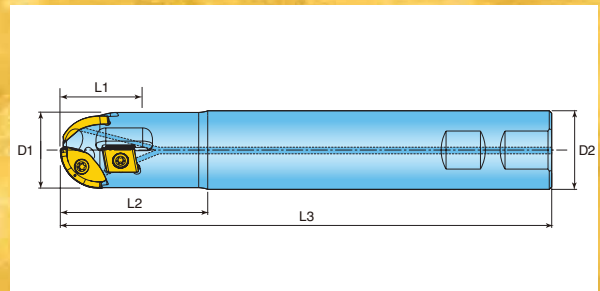

Cutter Number	D1 Effective Diameter	D2 Shank Size/Style	L1 Length of Cut	L2 Extension	L3 Overall Length	Effective Cutting Edges
2TW7K-1203781R01	1.250	1.250 Weldon	1.50	3.720	6.000	3
2TW7K-1205281R01	1.250	1.250 Weldon	1.50	5.220	7.500	3
2TW7K-1504386R01	1.500	1.500 Weldon	1.80	4.300	7.000	3
2TW7K-1506386R01	1.500	1.500 Weldon	1.80	6.300	9.000	3
2TW7K-2004782R01	2.000	2.000 Weldon	3.30	4.750	8.000	3
2TW7K-2007582R01	2.000	2.000 Weldon	3.30	7.750	11.000	3

Operating Guidelines on page 99.



PRO•TRIO PROFILE INSERTS

NCEU...R



NCEU...R-P

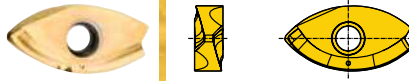

DCM

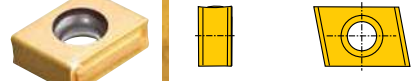

Cutter Dia.	Cutter Number	Center Ball Station	Side Ball Station	Side Station	Grade	IN2505	IN2530	IN6530
1.250	2TW7K-1203781R01	NCEU320500R (1)	NCEU320500R-P (2)	DCM323R01 (2)		•	•	•
1.250	2TW7K-1205281R01	NCEU320500R (1)	NCEU320500R-P (2)	DCM323R01 (2)		•	•	•
1.500	2TW7K-1504386R01	NCEU380600R (1)	NCEU380600R-P (2)	DCM323R01 (2)		•	•	•
1.500	2TW7K-1506386R01	NCEU380600R (1)	NCEU380600R-P (2)	DCM323R01 (2)		•	•	•
2.000	2TW7K-2004782R01	NCEU500700R (1)	NCEU500700R-P (2)	DCM324R01 (4)		•	•	•
2.000	2TW7K-2007582R01	NCEU500700R (1)	NCEU500700R-P (2)	DCM324R01 (4)		•	•	•

PRO•TRIO PROFILE HARDWARE



Screw



Driver

2TW7K-1203781R01	SM40-093-20	DS-T15T
2TW7K-1205281R01	SM40-093-20	DS-T15T
2TW7K-1504386R01	SM40-120-00	DS-T15T
2TW7K-1506386R01	SM40-120-00	DS-T15T
2TW7K-2004782R01	SM50-113-20	DS-T20T
2TW7K-2007582R01	SM50-113-20	DS-T20T

GOLD^oMAX⁴ FFIN™

SUPER FINISHING FACE MILL

- Cutter diameters from Ø3.00" thru Ø8.00"
- High precision cutter bodies with tangentially mounted inserts offering (4) insert indexes.
- Micro Finishing possible at 4X's the typical axial depth of cut.
- Large elliptical wiper follows lead cutting edge.
- Multiple carbide grades for all material types.



GOLD^oMAX⁴ FFIN™ SERIES EF6J

FINISHING FACEMILL

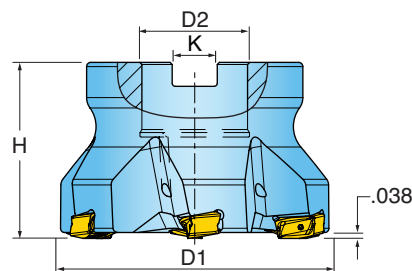

Cutter Number	D1 Nom. Diameter	# Effective Inserts	D2 Bore Diameter	D3 Effective Diameter	Max DOC	Bolt Circle	K Keyway	H Height	Coolant Thru	Insert Series
EF6J-03R01	3.000	5	1.000	2.243	0.038	-	0.380	1.750	Yes	DFH324L001
EF6J-04R01	4.000	6	1.500	3.234	0.038	-	0.630	2.500	Yes	DFH324L001
EF6J-05R01	5.000	7	1.500	4.237	0.038	-	0.630	2.500	Yes	DFH324L001
EF6J-06R01	6.000	9	1.500	5.234	0.038	-	0.630	2.500	Yes	DFH324L001
EF6J-08R01	8.000	9	2.500	7.235	0.038	4.000	1.010	2.500	Yes	DFH324L001

Operating Guidelines on page 100.

GOLD^oMAX⁴ FFIN™ INSERTS

DFH324

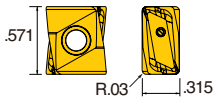
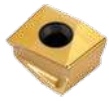

Insert Number	Corner Configuration	Application	Grade	IN2030	IN2505	IN2530	IN4015	IN4030
DFH324L001	4 x .030" R	Finishing Facemill		•	•	•	•	•

GOLD^oMAX⁴ FFIN™ HARDWARE



Screw

Driver

Retention Bolt

Coolant Plate

Coolant Plate Screw

EF6J-03R01	SM40-143-H0	DS-T15T	SD-08-46	-	-
EF6J-04R01	SM40-143-H0	DS-T15T	SD-12-82	-	-
EF6J-05R01	SM40-143-H0	DS-T15T	SD-12-82	-	-
EF6J-06R01	SM40-143-H0	DS-T15T	SD-12-82	-	-
EF6J-08R01	SM40-143-H0	DS-T15T	SD-10-70	CZ-0187	SE03-66

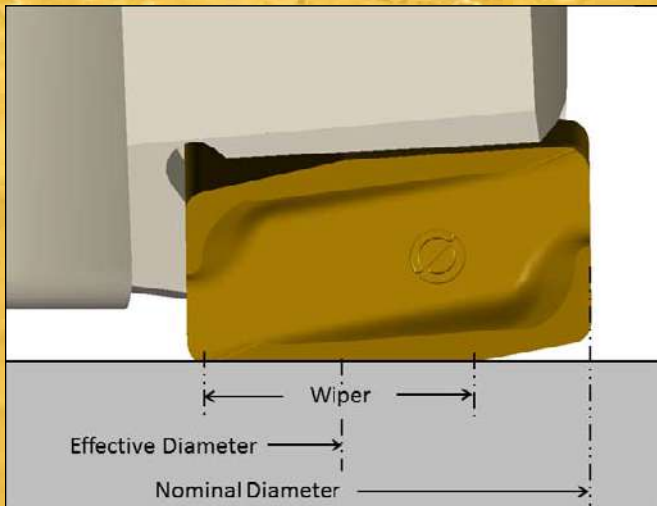

GOLD MAX⁸

DI-QUAD 90° LINE

DOUBLE-SIDED TANGENTIAL TECHNOLOGY

- Cutter Diameters from Ø2.00" thru Ø8.00"
- 8 Cutting Edges
- High Positive Geometry Produces True 90° Shoulders
- Unique Multifaceted Insert Offers High Efficiency and Productivity
- Stable Insert Seating Promotes Longer Tool Life

GOLD MAX⁸ SERIES VJ6K

0 DEGREE LEAD FACEMILL



Shoulder



Facing



Slabbing

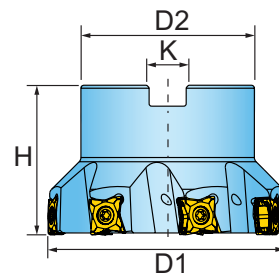

Cutter Number	D1 Nom. Diameter	Number of Inserts	H Height	D2 Bore Diameter	K Keyway	Bolt Circle
VJ6K-02R01	2.000	5	1.500	0.750	0.32	-
VJ6K-02R02	2.500	6	1.570	1.000	0.38	-
VJ6K-03R01	3.000	8	2.375	1.000	0.38	-
VJ6K-04R01	4.000	9	2.375	1.500	0.63	-
VJ6K-06R01	6.000	13	2.375	1.500	0.63	-
VJ6K-08R01	8.000	16	2.375	2.500	1.00	4.00

Operating Guidelines on page 100.

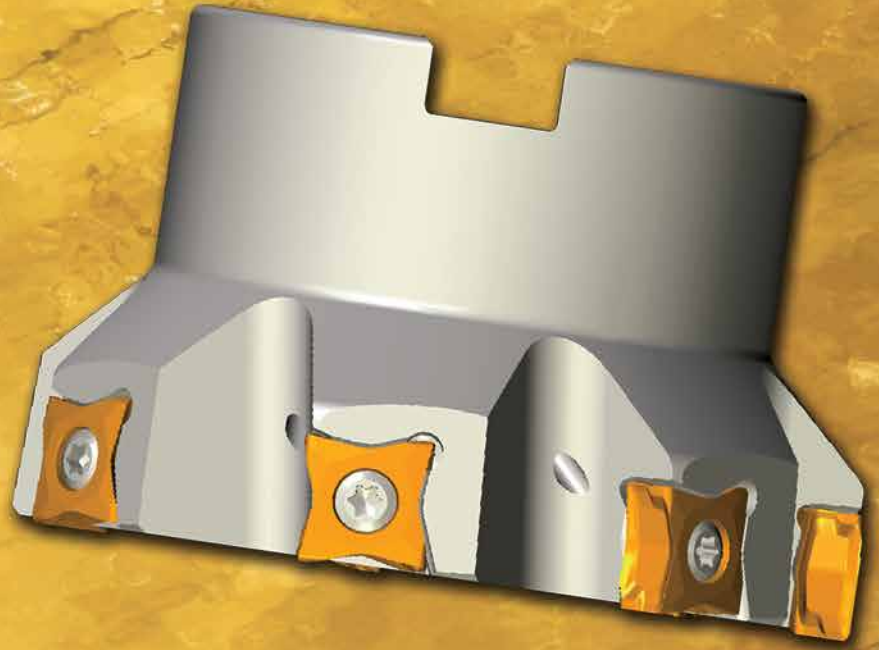

GOLD-MAX[®] INSERTS

SGM-44R001

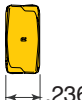
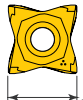

Cutter Number	Corner Configuration	Application	Grade	IN2030	IN2530	IN4030
SGM-44R001	8 x .031R	Multi-Purpose		•	•	•

GOLD-MAX[®] HARDWARE

HARDWARE



Screw

SM40-120-20



Driver

DS-T15T

GOLD MAX⁴

QUAD 90° LINE

THE EVOLUTION OF TECHNOLOGY CONTINUES WITH SLOTTERS

- Cutter Diameters from Ø4.00" thru Ø10.00"
- 4 insert indexes available in .031", .062", .093" & .125" corner radii
- Axial & radial drive available in .625", .750" & 1.00" widths of cut
- Same insert for both right-hand & left-hand stations
- Multiple grades for all material types



GOLD MAX⁴ SERIES 3EJ6

HEAVY DUTY AXIAL DRIVE SLOTTER



Slotting

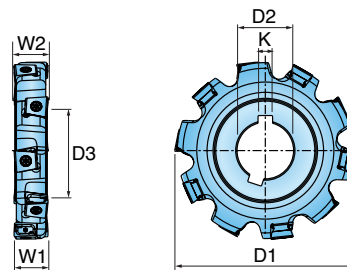

Cutter Number	W1 Cutter Width	D1 Nom. Diameter	D2 Bore Diameter	W2 Hub Width	D3 Hub Diameter	K Keyway	Total No. of Inserts	No. of Effective Inserts	Insert Series
3EJ6F-04062AG-01	0.625	4.000	1.250	0.595	2.25	0.312	10	5	DGM315
3EJ6J-04075AG-01	0.750	4.000	1.250	0.720	2.25	0.312	10	5	DGM325
3EJ6M-04100AG-01	1.000	4.000	1.250	0.970	2.25	0.312	8	4	DGM426
3EJ6F-05062AH-01	0.625	5.000	1.500	0.595	2.75	0.375	12	6	DGM315
3EJ6J-05075AH-01	0.750	5.000	1.500	0.720	2.75	0.375	12	6	DGM325
3EJ6M-05100AH-01	1.000	5.000	1.500	0.970	2.75	0.375	10	5	DGM426
3EJ6F-06062AH-01	0.625	6.000	1.500	0.595	3.50	0.375	14	7	DGM315
3EJ6J-06075AH-01	0.750	6.000	1.500	0.720	3.50	0.375	14	7	DGM325
3EJ6M-06100AH-01	1.000	6.000	1.500	0.970	3.50	0.375	12	6	DGM426
3EJ6F-08062AK-01	0.625	8.000	2.000	0.595	3.50	0.500	16	8	DGM315
3EJ6J-08075AK-01	0.750	8.000	2.000	0.720	3.50	0.500	16	8	DGM325
3EJ6M-08100AK-01	1.000	8.000	2.000	0.970	3.50	0.500	14	7	DGM426
3EJ6F-10062AK-01	0.625	10.000	2.000	0.595	3.50	0.500	18	9	DGM315
3EJ6J-10075AK-01	0.750	10.000	2.000	0.720	3.50	0.500	18	9	DGM325
3EJ6M-10100AK-01	1.000	10.000	2.000	0.970	3.50	0.500	16	8	DGM426

Operating Guidelines on page 101.



GOLD^{MAX}4 SERIES 3EJ6
GRADE 5000 VMC

HEAVY DUTY RADIAL DRIVE SLOTTER

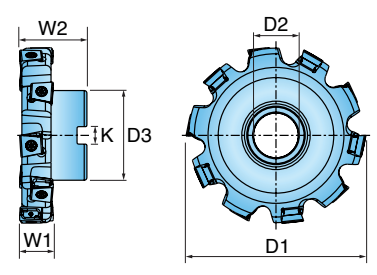

Cutter Number	W1 Cutter Width	D1 Nom. Diameter	D2 Bore Diameter	W2 Hub Width	D3 Hub Diameter	K Keyway	Total No. of Inserts	No. of Effective Inserts	Insert Series
3EJ6F-0406257R01	0.625	4.000	1.000	1.500	2.00	0.375	10	5	DGM315
3EJ6J-0407557R01	0.750	4.000	1.000	1.500	2.00	0.375	10	5	DGM325
3EJ6M-0410057R01	1.000	4.000	1.000	1.500	2.00	0.375	8	4	DGM426
3EJ6F-0506257R01	0.625	5.000	1.000	1.500	2.75	0.375	12	6	DGM315
3EJ6J-0507557R01	0.750	5.000	1.000	1.500	2.75	0.375	12	6	DGM325
3EJ6M-0510057R01	1.000	5.000	1.000	1.500	2.75	0.375	10	5	DGM426
3EJ6F-0606258R01	0.625	6.000	1.500	2.000	2.75	0.625	14	7	DGM315
3EJ6J-0607558R01	0.750	6.000	1.500	2.000	2.75	0.625	14	7	DGM325
3EJ6M-0610058R01	1.000	6.000	1.500	2.000	3.81	0.625	12	6	DGM426
3EJ6F-0806258R01	0.625	8.000	1.500	2.000	3.81	0.625	16	8	DGM315
3EJ6J-0807558R01	0.750	8.000	1.500	2.000	3.81	0.625	16	8	DGM325
3EJ6M-0810058R01	1.000	8.000	1.500	2.000	3.81	0.625	14	7	DGM426
3EJ6F-1006261R01	0.625	10.000	2.500	2.000	4.87	1.000	18	9	DGM315
3EJ6J-1007561R01	0.750	10.000	2.500	2.000	4.87	1.000	18	9	DGM325
3EJ6M-1010061R01	1.000	10.000	2.500	2.000	4.87	1.000	16	8	DGM426

Operating Guidelines on page 101.



DGM315



DGM325



DGM426



Part Number	R Corner	Applications	Grade								
				IN2505	IN2515	IN2530	IN2540	IN4005	IN4015	IN4030	IN4040
DGM315-001	0.031 R	Multi-Purpose		•	•	•	•	•	•	•	•
DGM315-002	0.062 R	Multi-Purpose		•	•	•	•	•	•	•	•
DGM315-003	0.093 R	Multi-Purpose		•	•	•	•	•	•	•	•
DGM315-004	0.125 R	Multi-Purpose		•	•	•	•	•	•	•	•
DGM325-001	0.031 R	Multi-Purpose		•	•	•	•	•	•	•	•
DGM325-002	0.062 R	Multi-Purpose		•	•	•	•	•	•	•	•
DGM325-003	0.093 R	Multi-Purpose		•	•	•	•	•	•	•	•
DGM325-004	0.125 R	Multi-Purpose		•	•	•	•	•	•	•	•
DGM426-001	0.031 R	Multi-Purpose		•	•	•	•	•	•	•	•
DGM426-002	0.062 R	Multi-Purpose		•	•	•	•	•	•	•	•
DGM426-003	0.093 R	Multi-Purpose		•	•	•	•	•	•	•	•
DGM426-004	0.125 R	Multi-Purpose		•	•	•	•	•	•	•	•



Screw



Driver

DGM315	SM40-143-H0	DS-T15T
DGM325	SM40-143-H0	DS-T15T
DGM426	SM50-160-10	DS-T20T

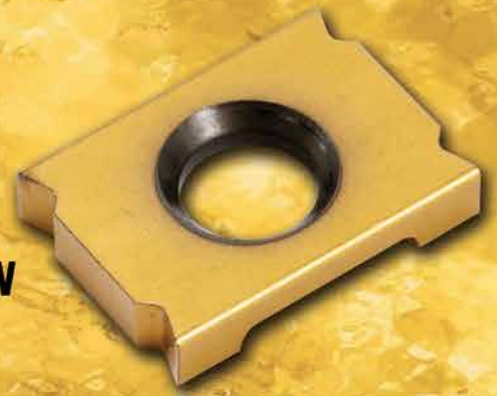

SUPER-MAX PERFORMANCE IN A THIN SLOTTER DESIGN

- Diameters from Ø3.00" thru Ø8.00"
- Cutting Widths Ranging From .125" thru .312"
- Same 4 Index Insert for Both RH and LH Stations
- Ridgid Bridge-Style Insert Mounting

THINOMAX™ SERIES 3VJ5V

AXIAL DRIVE SLOTTER

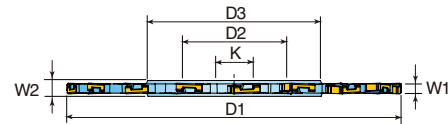

Cutter Number	W1 Cutter Width	D1 Nom. Diameter	D2 Bore Diameter	W2 Hub Width	D3 Hub Diameter	K Keyway	Total # of Inserts	# of Effective Inserts	Insert Series
3VJ5V-03012AF-01	0.125	3.000	1.000	0.375	1.560	0.250	10	5	IEE211-001
3VJ5V-04012AF-01	0.125	4.000	1.000	0.375	1.750	0.250	14	7	IEE211-001
3VJ5V-03015AF-01	0.156	3.000	1.000	0.375	1.560	0.250	10	5	IEE311-001
3VJ5V-04015AF-01	0.156	4.000	1.000	0.375	1.750	0.250	12	6	IEE311-001
3VJ5V-06015AG-01	0.156	6.000	1.250	0.375	1.870	0.312	18	9	IEE311-001
3VJ5V-03018AF-01	0.187	3.000	1.000	0.375	1.560	0.250	10	5	IEE312-001
3VJ5V-04018AF-01	0.187	4.000	1.000	0.375	1.750	0.250	12	6	IEE312-001
3VJ5V-05018AG-01	0.187	5.000	1.250	0.375	1.870	0.312	14	7	IEE312-001
3VJ5V-06018AG-01	0.187	6.000	1.250	0.375	1.870	0.312	18	9	IEE312-001
3VJ5V-04025AF-01	0.250	4.000	1.000	0.375	1.750	0.250	10	5	IXE412-001
3VJ5V-05025AF-01	0.250	5.000	1.000	0.375	1.870	0.250	12	6	IXE412-001
3VJ5V-06025AG-01	0.250	6.000	1.250	0.375	1.870	0.312	14	7	IXE412-001
3VJ5V-08025AH-01	0.250	8.000	1.500	0.375	2.750	0.375	18	9	IXE412-001
3VJ5V-04031AG-01	0.312	4.000	1.250	0.375	1.870	0.312	10	5	IXE413-001
3VJ5V-05031AG-01	0.312	5.000	1.250	0.375	1.870	0.312	12	6	IXE413-001
3VJ5V-06031AG-01	0.312	6.000	1.250	0.375	1.870	0.312	14	7	IXE413-001
3VJ5V-08031AH-01	0.312	8.000	1.500	0.375	2.750	0.375	18	9	IXE413-001
3VJ5V-04037AG-01	0.375	4.000	1.250	0.345	1.870	0.312	10	5	IXE414-001
3VJ5V-06037AG-01	0.375	6.000	1.250	0.345	1.870	0.312	14	7	IXE414-001
3VJ5V-08037AH-01	0.375	8.000	1.500	0.345	2.750	0.375	18	9	IXE414-001



THINOMAX™ SERIES 3VJ5V
TANGENTIAL

RADIAL DRIVE SLOTTOR



Slotting

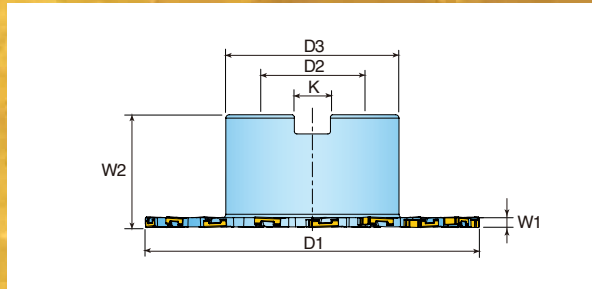

Cutter Number	W1 Cutter Width	D1 Nom. Diameter	D2 Bore Diameter	W2 Hub Width	D3 Hub Diameter	K Keyway	Total # of Inserts	# of Effective Inserts	Insert Series
3VJ5V-02012D1R01	0.125	2.500	0.750	1.375	1.180	0.312	8	4	IEE211-001
3VJ5V-03012D1R01	0.125	3.000	0.750	1.500	1.500	0.312	10	5	IEE211-001
3VJ5V-04012D3R01	0.125	4.000	1.000	1.500	1.750	0.375	14	7	IEE211-001
3VJ5V-02015D1R01	0.156	2.500	0.750	1.375	1.180	0.312	8	4	IEE311-001
3VJ5V-03015D1R01	0.156	3.000	0.750	1.500	1.500	0.312	10	5	IEE311-001
3VJ5V-04015D3R01	0.156	4.000	1.000	1.500	1.750	0.375	12	6	IEE311-001
3VJ5V-0601558R01	0.156	6.000	1.500	2.000	3.070	0.625	18	9	IEE311-001
3VJ5V-02018D1R01	0.187	2.500	0.750	1.375	1.180	0.312	8	4	IEE312-001
3VJ5V-03018D1R01	0.187	3.000	0.750	1.500	1.500	0.375	10	5	IEE312-001
3VJ5V-04018D3R01	0.187	4.000	1.000	1.500	1.750	0.375	12	6	IEE312-001
3VJ5V-05018D3R01	0.187	5.000	1.000	1.500	2.250	0.375	14	7	IEE312-001
3VJ5V-0601858R01	0.187	6.000	1.500	2.000	3.070	0.625	18	9	IEE312-001
3VJ5V-02025D1R01	0.250	2.500	0.750	1.500	1.180	0.312	6	3	IXE412-001
3VJ5V-03025D1R01	0.250	3.000	0.750	1.500	1.500	0.312	8	4	IXE412-001
3VJ5V-04025D3R01	0.250	4.000	1.000	1.500	1.750	0.312	10	5	IXE412-001
3VJ5V-05025D3R01	0.250	5.000	1.000	1.500	2.250	0.375	12	6	IXE412-001
3VJ5V-0602558R01	0.250	6.000	1.500	2.000	3.070	0.625	14	7	IXE412-001
3VJ5V-04031D3R01	0.312	4.000	1.000	1.500	1.750	0.375	10	5	IXE413-001
3VJ5V-0603158R01	0.312	6.000	1.500	2.000	3.070	0.625	14	7	IXE413-001
3VJ5V-0803158R01	0.312	8.000	1.500	2.000	3.800	0.625	18	9	IXE413-001
3VJ5V-04037D3R01	0.375	4.000	1.000	1.500	1.750	0.375	10	5	IXE414-001
3VJ5V-05037D3R01	0.375	5.000	1.000	1.500	2.250	0.375	12	6	IXE414-001
3VJ5V-0603758R01	0.375	6.000	1.500	2.000	3.070	0.625	14	7	IXE414-001
3VJ5V-0803758R01	0.375	8.000	1.500	2.000	3.800	0.625	18	9	IXE414-001

Operating Guidelines on page 101.

THINoMAX™ INSERTS
TANGENTIAL



Insert Number	Corner Configuration	Application	Grade						
				IN2505	IN2515	IN2530	IN4005	IN4015	IN4030
IEE211-001	4 x .015" R	Multi-Purpose		•		•	•		•
IEE311-001	4 x .015" R	Multi-Purpose		•	•	•	•	•	•
IEE311-002	4 x .031" R	Multi-Purpose		•	•	•	•	•	•
IEE312-001	4 x .015" R	Multi-Purpose		•	•	•	•	•	•
IEE312-002	4 x .031" R	Multi-Purpose		•	•	•	•	•	•
IXE412-001	4 x .015" R	Multi-Purpose		•	•	•	•	•	•
IXE412-002	4 x .031" R	Multi-Purpose		•	•	•	•	•	•
IXE412-003	4 x .062" R	Multi-Purpose		•	•	•	•	•	•
IXE413-001	4 x .015" R	Multi-Purpose		•	•	•	•	•	•
IXE413-002	4 x .031" R	Multi-Purpose		•	•	•	•	•	•
IXE413-003	4 x .062" R	Multi-Purpose		•	•	•	•	•	•
IXE414-001	4 x .015" R	Multi-Purpose		•	•	•	•	•	•
IXE414-002	4 x .031" R	Multi-Purpose		•	•	•	•	•	•
IXE414-003	4 x .062" R	Multi-Purpose		•	•	•	•	•	•



Screw



Driver

IEE211	SM25-025-80	DS-T06F	M2.5 x .45MM x 2.5MM
IEE311	SM35-034-50	DS-T09W	M3.5 x .60MM x 3.4MM
IEE312	SM35-042-50	DS-T09W	M3.5 x .60MM x 4.2MM
IXE412	SM40-055-50	DS-T15T	M4.0 x .70MM x 5.5MM
IXE413	SM40-070-50	DS-T15T	M4.0 x .70MM x 7.0MM
IXE414	SM40-080-50	DS-T15T	M4.0 x .70MM x 8.0MM

HiPos + - 12mm I.C. - Series 12S1X		Brinell Hardness	SFM	Feed per Insert	IN10K	IN2005/2505	IN2510	IN1030	IN2530	IN2040/2540	Coolant
Material											
Aluminum	6061-T6, 7075-T6, 2024	-	1500-8000	.004 - .010	1	3	2				Yes
Cast Iron	Gray	150 - 250	300 - 1000	.004 - .010		2	1				No
	Nodular		300 - 600								
Steel	Low Carbon 1018, 8620	100 - 250	400 - 1000	.004 - .010		2		1	1*	3	No
	High Carbon F-6180	250 - 400	350 - 500	.004 - .008							
	Alloyed Steel 4140, 4340	150 - 300	300 - 700	.004 - .010							
	Tool Steel A-6, D-1, D-2	Up to 300									
Stainless Steel	300 Series, 304, 316	-	300 - 700	.004 - .010		2		1	1*	3	May not be required at high speeds
	400 Series, 15-5 PH, 17-4 PH	-	400 - 900								Yes
	13-8 PH	-	200 - 400								Yes
Nickel Alloys	Inconel 600, 706, 718, 903, Hastelloy, Waspalloy	-	75-120	.003 - .006		2	3	1	1*		Yes
Titanium	6AL-4V, TI-10-2-3, TI-5553	-	100 - 150	.005 - .008		2		1	1		Yes

HiPos + - 18mm I.C. - Series 12S1E		Brinell Hardness	SFM	Feed per Insert	IN10K	IN2005/2505	IN2510	IN1030	IN2530	IN2040/2540	Coolant
Material											
Aluminum	6061-T6, 7075-T6, 2024	-	1500-8000	.004 - .018	1	3	2				Yes
Cast Iron	Gray	150 - 250	300 - 1000	.004 - .018		2					No
	Nodular		300 - 600								
Steel	Low Carbon 1018, 8620	100 - 250	400 - 1000	.004 - .018		2		1	1*	3	No
	High Carbon F-6180	250 - 400	350 - 500	.004 - .015							
	Alloyed Steel 4140, 4340	150 - 300	300 - 700	.004 - .018							
	Tool Steel A-6, D-1, D-2	Up to 300									
Stainless Steel	300 Series, 304, 316	-	300 - 700	.004 - .018		2	3	1	1*		May not be required at high speeds
	400 Series, 15-5 PH, 17-4 PH	-	400 - 900								Yes
	13-8 PH	-	200 - 400								Yes
Nickel Alloys	Inconel 600, 706, 718, 903, Hastelloy, Waspalloy	-	75-120	.003 - .006		1	3	2	2		Yes
Titanium	6AL-4V, TI-10-2-3, TI-5553	-	100 - 150	.005 - .008		2		1	1		Yes

HiPos Trio - 6mm I.C. - Series 1KJ1D, 1KV1D, KJ5D, KJ6D					IN10K	IN2505	IN2510	IN2530	IN2540	Coolant
Material	Brinnell Hardness	SFM	Feed per Insert							
Aluminum	6061 T6, 7075 T6, 2024	-	1500 - 8000	.003 - .006	1					Yes
Cast Iron	Gray	150 - 250	500 - 1200	.002 - .006		2	1			No
	Nodular		400 - 800							
Steel	Low Carbon 1018, 8620	150 - 250	600 - 1200	.002 - .006		2		1	3	No
	High Carbon F-6180, Nitalloy 52100	250 - 400	400 - 600	.002 .005						
	Alloyed Steel 4140, 4340, 6150	150 - 300	400 - 800							
	Tool Steel A-6, D-1, D-2, P20	Up to 300								
Stainless Steel	300 Series, 304, 316	-	400 - 800	.002 - .005		2		1	3	May not be required at high speeds
	400 Series 15-5 PH, 17-4 PH	Up to 320	500 - 1000							Yes
	13-8 PH	-	200 - 400							
Nickel Alloys	Inconel 600, 706, 718, 903, Hastelloy, Waspalloy	-	75-120	.002 - .004		2	3	1		Yes
Titanium	6AL-4V	-	100 - 150	.002 - .005		2		1		Yes

HiPos Trio - 10mm I.C. - Series 1KJ1G, KJ5G, KJ6G					IN10K	IN2505	IN2510	IN2530	IN2540	Coolant
Material	Brinnell Hardness	SFM	Feed per Insert							
Aluminum	6061 T6, 7075 T6, 2024	-	1500 - 8000	.004 - .010	1					
Cast Iron	Gray	150 - 250	300 - 1000	.004 - .008		2	1			No
	Nodular		300 - 600							
Steel	Low Carbon 1018, 8620	150 - 250	400 - 1000	.004 - .008		2		1	3	No
	High Carbon F-6180, Nitalloy 52100	250 - 400	350 - 500	.004 - .006						
	Alloyed Steel 4140, 4340, 6150	150 - 300	300 - 700	.004 - .008						
	Tool Steel A-6, D-1, D-2, P20	Up to 300								
Stainless Steel	300 Series, 304, 316	-	300 - 700	.004 - .006		2		1	3	May not be required at high speeds
	400 Series 15-5 PH, 17-4 PH	Up to 320	400 - 900							Yes
	13-8 PH	-	200 - 400							
Nickel Alloys	Inconel 600, 706, 718, 903, Hastelloy, Waspalloy	-	75-120	.003 - .005		2	3	1		Yes
Titanium	6AL-4V	-	100 - 150	.005 - .005		2		1		Yes

HiPos Trio - 13mm I.C. - Series 1KJ1P, KJ5P, KJ6P										
Material	Brinnell Hardness	SFM	Feed per Insert	IN10K	IN2505	IN2510	IN2530	IN2540	Coolant	
Aluminum	6061 T6, 7075 T6, 2024	-	1500 - 8000	.004 - .010	1					
Cast Iron	Gray	150 - 250	300 - 1000	.004 - .010		2	1			No
	Nodular		300 - 600							
Steel	Low Carbon 1018, 8620	150 - 250	400 - 1000	.004 - .010		2		1	3	No
	High Carbon F-6180, Nitr alloy 52100	250 - 400	350 - 500	.004 - .008						
	Alloyed Steel 4140, 4340, 6150	150 - 300	300 - 700	.004 - .010						
	Tool Steel A-6, D-1, D-2, P20	Up to 300								
Stainless Steel	300 Series, 304, 316	-	300 - 700	.004 - .008		2		1		May not be required at high speeds
	400 Series 15-5 PH, 17-4 PH	Up to 320	400 - 900							Yes
	13-8 PH	-	200 - 400							
Nickel Alloys	Inconel 600, 706, 718, 903, Hastelloy, Waspalloy	-	75-120	.003 - .006		2	3	1		Yes
Titanium	6AL-4V	-	100 - 150	.005 - .006		2		1		Yes

DiPos Hexa - Series 1DJ1F, DJ5F, 1DJ1P, DJ5P, DJ6P										
Material	Brinnell Hardness	SFM	Feed per Insert	IN10K	IN2505	IN2510	IN2530	IN2540	Coolant	

Aluminum	6061 T6, 7075 T6, 2024	-	1500-8000	.004 - .010	1					
Cast Iron	Gray	150 - 250	300 - 1000	.004 - .010		2	1			No
	Nodular		300 - 600							
Steel	Low Carbon 1018, 8620	150 - 250	400 - 1000	.004 - .010		2		1	3	No
	High Carbon F-6180, Nitr alloy 52100	250 - 400	350 - 500	.004 - .008						
	Alloyed Steel 4140, 4340, 6150	150 - 300	300 - 700	.004 - .010						
	Tool Steel A-6, D-1, D-2, P20	Up to 300								
Stainless Steel	300 Series, 304, 316	-	300 - 700	.004 - .010		2		1		May not be required at high speeds
	400 Series 15-5 PH, 17-4 PH	Up to 320	400 - 900							Yes
	13-8 PH	-	200 - 400							
Nickel Alloys	Inconel 600, 706, 718, 903, Hastelloy, Waspalloy	-	75-120	.003 - .006		2		1		Yes
Titanium	6AL-4V	-	100 - 150	.005 - .008		2		1		Yes

Hi-Quad Long Edge Cutters - Series 25J3P					IN4005	IN4030	IN4035	IN4015	Coolant
Material	Brinnell Hardness	SFM	Feed per Insert						
Aluminum	6061 T6, 7075 T6, 2024	-	1000 - 5000	.004 - .018				1	Yes
Cast Iron	Gray	150 - 250	300 - 800	.004 - .010	2			1	No
	Nodular		300 - 500						
Steel	Low Carbon 1018, 8620	100 - 250	400 - 800	.004 - .010	3	2	1		No
	High Carbon F-6180	250 - 400	350 - 500	.004 - .008					
	Alloyed Steel 4140, 4340	150 - 300	300 - 600	.004 - .010					
	Tool Steel A-6, D-1, D-2	Up to 300							
Stainless Steel	300 Series, 304, 316	-	300 - 450	.004 - .010	3	2	1		May not be required at high speeds
	400 Series 15-5 PH	Up to 320	350 - 500						Yes
	13-8 PH	-	200 - 400						
Nickel Alloys	Inconel, Hastelloy, Waspalloy	-	65-110	.003 - .006	3	2	1		Yes
Titanium	6AL-4V	-	90 - 120	.005 - .008	3	2	1		Yes

STARTING FEED RATE GUIDELINES FOR EXTENDED FLUTE MILL BASED ON WIDTH OF CUT

Material	Material Specification	Radial WOC	Feed Rate (APT)			
			2.00 Diameter	2.50 Diameter	3.00 Diameter	4.00 Diameter
Aluminum	7075 - T6, 6061 - T6, 2024	0.02	0.050	0.060	0.070	0.080
		Diameter / 8	0.015	0.015	0.015	0.015
		Diameter / 4	0.012	0.012	0.012	0.012
		Diameter / 2	0.010	0.010	0.010	0.010
Cast Iron	Gray / Nodular	0.02	0.035	0.048	0.056	0.064
		Diameter / 8	0.009	0.011	0.011	0.011
		Diameter / 4	0.007	0.008	0.008	0.008
		Diameter / 2	0.006	0.006	0.006	0.006
Steel	Low / Med Carbon 1018, 1045, 8620	0.02	0.035	0.048	0.056	0.064
		Diameter / 8	0.009	0.011	0.011	0.011
		Diameter / 4	0.007	0.008	0.008	0.008
		Diameter / 2	0.006	0.006	0.006	0.006
	Alloyed Steel, 4140, 4340, Tool Steel A-6, D-1, D-2	0.02	0.030	0.042	0.049	0.056
		Diameter / 8	0.008	0.009	0.009	0.009
		Diameter / 4	0.006	0.007	0.007	0.007
		Diameter / 2	0.005	0.005	0.005	0.005
Stainless Steel	300 Series, 304, 316, 13-8PH	0.02	0.030	0.042	0.049	0.056
		Diameter / 8	0.008	0.009	0.009	0.009
		Diameter / 4	0.006	0.007	0.007	0.007
		Diameter / 2	0.005	0.005	0.005	0.005
	400 Series 15-5PH, 17-4PH	0.02	0.035	0.048	0.056	0.064
		Diameter / 8	0.009	0.011	0.011	0.011
		Diameter / 4	0.007	0.008	0.008	0.008
		Diameter / 2	0.006	0.006	0.006	0.006
Nickel Alloys & Titanium	Inconel, Hastelloy, Waspalloy, 6AL-4V	0.02	0.030	0.042	0.049	0.056
		Diameter / 8	0.008	0.009	0.009	0.009
		Diameter / 4	0.006	0.007	0.007	0.007
		Diameter / 2	0.005	0.005	0.005	0.005

IsoPlus - Series DJ6T, DJ5T					IN2510	IN2530	IN2505	IN2540	IN6515	IN71N	Coolant
Material	Brinnell Hardness	SFM	Feed per Insert								
Aluminum	7075 - T6, 6061 - T6, 2024	-	1500-10000	.006-.012	1						Yes
Cast Iron	Gray	150-250	500-1000	.008-.010	1				2		No
			1800+	.005-.008					1		
	Nodular		400-800	.007-.009	2				1		
			1500+	.004-.007						1	
Steel	Low Carbon 1018, 8620	100-250	400-1000	.006-.010							No
	High Carbon F-6180	250-400	400-800			1	3	2			
	Alloyed Steel 4140, 4340	150-300	300-700								
	Tool Steel A-6, D-1, D-2	Up to 300	300-500								
Stainless Steel	300 Series, 304, 316	-	300-700	.005-.008							May not be required at high speeds
	400 Series 15-5 PH	Up to 320	400-700			1	2				
	13-8 PH	-	200-400							Yes	
Nickel Alloys	Inconel, Hastelloy, Waspalloy	-	75-120	.003-.006		2	1				Yes
Titanium	6AL-4V	-	100-150	.004-.007		1	2				Yes

OctoPlus - Series ON5H, ON6H, OP6N										IN10K	IN2004	IN2005/2505	IN2030	IN2035	IN2040	IN6510/2510	IN6515	IN70N	Coolant	
Material	Brinnell Hardness	SFM	Feed per Insert																	
Aluminum	7075 - T6, 6061 - T6, 2024	-	1500-10000	.006-.012	1															Yes
Cast Iron	Gray	150-250	500-1000	.008-.016		3					1	2								No
			1800+	.005-.008										1						
	Nodular		400-800	.007-.014		3						2	1							
			1500+	.004-.007										1						
Steel	Low Carbon 1018, 8620	100-250	400-1000	.006-.015																No
	High Carbon F-6180	250-400	400-800	.006-.012			2	1		3										
	Alloyed Steel 4140, 4340	150-300	300-700																	
	Tool Steel A-6, D-1, D-2	Up to 300	300-500																	
Stainless Steel	300 Series, 304, 316	-	300-700		.005-.009															
	400 Series 15-5 PH	Up to 320	400-700			3	2	1	4											
	13-8 PH	-	200-400											Yes						
Nickel Alloys	Inconel, Hastelloy, Waspalloy	-	75-120	.003-.006			1	3	2											Yes
Titanium	6AL-4V	-	100-150	.004-.007			3	1	2											Yes

FormMaster F - Series 1DG1H, DG6H					IN2030	IN2505	IN2540	IN6530	Coolant
Material	Brinnell Hardness	SFM	Feed per Insert						
Steel	Mild 1018 - 1045	125 - 425	300 - 650	.035 - .157	1				No
	Low Alloy 4140, 8620, 4340	150 - 425			300 - 700	1	1	3	
	Med Alloy P20, S7, H13, O1, A2								
Stainless Steel	Free Machining 303, 416	150 - 425	200 - 550	.030 - .100	1	2	3	4	No
	300 Series 304, 310, 316								
	400 Series 410, 420, 15-5PH, 17-4 PH								
	PH Series 13-8								
Hardened Steel	ALL	-	200 - 400	.030 - .075	1	2			No

HiFeedMini - Series 1TG1F, TG1F					IN2030	IN2505	IN2540	IN6530	Coolant
Material	Brinnell Hardness	SFM	Feed per Insert						
Steel	Mild 1018 - 1045	125 - 425	500 - 1100	.010 - .035		1	2	2	No
	Low Alloy 4140, 8620, 4340	150 - 425	400 - 1000	.008 - .018	1	3	2	4	
	Med Alloy P20, S7, H13, O1, A2	150 - 425	300 - 900						
	High Alloy A7-D2	200 - 425	300 - 600	.005 - .015	1	2		3	
Stainless Steel	Free Machining 303, 416	150 - 425	300 - 800	.010 - .030	2	1		3	No
	300 Series 304, 310, 316	150 - 425	200 - 600	.005 - .015					
	400 Series 410, 420, 15-5PH, 17-4 PH	150 - 425							
	PH Series 13-8	150 - 425	200 - 500						
Hardened Steel	ALL	-	200 - 400	.002 - .010	1		2	3	No

HiQuad F - Series 15M1P, 5M_P, 5G_M					IN2505	IN2530	IN4005	IN4030	IN4035	Coolant
Material	Brinnell Hardness	SFM	Feed per Insert							
Steel	Mild 1018-1045	125-425	300-650	.025-.115	2	1		3	NO	
	Low Alloy 4140, 8620, 4340	150-425			2	1		3	NO	
	Med Alloy P20, S7, H13, O1, A2		2		3	1		3	NO	
Stainless Steel	Free Machining 303, 416	150-425	220-550	.025-.110	5	3	4	1	2	NO
	300 Series 304, 310, 316				5	3	4	1	2	NO
	400 Series 410, 420, 15-5PH, 17-4 PH				5	3	4	1	2	YES
	PH Series 13-8				5	3	4	1	2	YES
Hardened Steel	ALL	-	200-400	.030-.050	2		1		3	NO
Titanium	6AL-4V	-	90-200	.030-.060	5	3	4	1	2	YES

Note: Feed and speed recommendations are starting operating parameters. They are only guidelines from which further optimization should take place. Operating parameters are influenced by many machining variables. These variables may cause for reductions in feeds and speed or dramatic increases. Additionally, DOC and WOC may need to be revised to optimize the tools performance.

HiQuad Plungers - Series QHU, 5J1P					IN4005	IN4030	IN4035	IN4015	Coolant
Material	Brinnell Hardness	SFM	Feed per Insert						
Aluminum	6061 T6, 7075 T6, 2024	-	1500 - 8000	.004 - .010				1	Yes
Cast Iron	Gray	150 - 250	250 - 800	.005 - .012	2			1	No
	Nodular		200 - 800						
Steel	Low Carbon 1018, 8620	100 - 250	250 - 800	.004 - .012	2	1			No
	High Carbon F-6180	250 - 400	200 - 700	.005 - .012					
	Alloyed Steel 4140, 4340	150 - 300	250 - 700						
	Tool Steel A-6, D-1, D-2	Up to 300							
Stainless Steel	300 Series, 304, 316	-	250 - 600	.004 - .008	3	2	1		May not be required at high speeds
	400 Series 15-5 PH	Up to 320	300 - 700	.005 - .010					
	13-8 PH	-	200 - 250	.004 - .008					Yes
Nickel Alloys	Inconel, Hastelloy, Waspalloy	-	75-120	.004 - .008	3	2	1		Yes
Titanium	6AL-4V	-	100 - 150	.004 - .008	3	2	1		Yes

IsoPlus High Feed - Series DD6H					IN2530	IN2505	IN2540	IN2510	IN6515	IN2035	Coolant
Material	Brinnell Hardness	SFM	Feed per Insert								
Cast Iron	Gray	150-250	600-1000	.030-.130				1	2		No
	Nodular		150-250					2	1		
Steel	Mild 1018, 1045	125-425	300-650	.025-.115	1	2	3				No
	Low Alloy 4140, 4340, 8620	150-425						300-700			
	Med Alloy P20, S7, H13, A2										
Stainless Steel	300 Series, 304, 316	Up to 320	200-550	.025-.110	2	3	4			1	May not be required at high speeds
	400 Series, 15-5 PH, 17-4 PH										
	13-8 PH										
Hardened Steel	All	-	200-400	.030-.050	2	1					No
Nickel Alloys	Inconel, Hastelloy, Waspalloy	-	75-120	.030-.080		3	2			1	Yes
Titanium	6AL-4V	-	100-150	.030-.060		2	3			1	Yes

DiPos TETRA - Series 1TJ10, TJ50, TJ60, 1TJ1N, TJ5N, TJ6N, TN1N											
Material	Brinnell Hardness	SFM	Feed per Insert	IN10K	IN2505	IN2510	IN2530	IN2540	IN6515	Coolant	
Aluminum	6061-T6, 7075-T6, 2024	-	1500 - 8000	.004 - .018	1					Yes	
Cast Iron	Gray	150 - 250	300 - 1000	.004 - .009		3	1			2	No
	Nodular		300 - 600			3	2			1	
Steel	Low Carbon 1018, 8620	150 - 250	400 - 1000	.004 - .009	2		1	3		No	
	High Carbon F-6180, Nitalloy 52100	250 - 400	350 - 500	.004 - .007							
	Alloyed Steel 4140, 4340, 6150	150 - 300	300 - 700	.004 - .009							
	Tool Steel A-6, D-1, D-2, P20	Up to 300									
Stainless Steel	300 Series, 304, 316	-	300 - 550	.004 - .009	2		1	3		May not be required at high speeds	
	400 Series 15-5 PH, 17-4 PH	Up to 320	350 - 600							Yes	
	13-8 PH	-	200 - 400								
Nickel Alloys	Inconel 600, 706, 718, 903, Hastelloy, Waspalloy	-	75-120	.003 - .006	2		1			Yes	
Titanium	6AL-4V	-	100 - 150	.005 - .008	2		1			Yes	

FormMasterShear - Series 15B1B, 1A7_					IN1030	IN6530	IN2530	IN2540	IN2505	IN055	Coolant
Material	Brinnell Hardness	SFM	Feed per Insert								
Aluminum	6061-T6, 7075-T6		1300-1650	.0075 - .047						1	YES
Cast Iron	Gray	190-220	360 - 690	.005 - .022		3	2		1		NO
	Nodular	140-200	140-200			3	2		1		NO
Steel	Low Carbon 1018-8620	85-175	721 - 985	.005 - .024			2		1		NO
	High Carbon F-6180	175 - 225	490 - 820	.005 - .024			2		1		NO
	Alloyed Steel 4140	275-325	325 - 590	.005 - .022			2	3	1		NO
	Tool Steel P20-H13	200-250	275 - 495	.005 - .022			2		1		NO
Stainless Steel	300 Series, 304, 316	-	360 - 590	.005 - .021	3	2	1		4		OPTIONAL
	400 Series 15-5 PH, 17-4 PH	-	360 - 720	.005 - .021	3	2	1		4		OPTIONAL
	13-8 PH	-	200 - 600	.005 - .015	3	2	1		4		OPTIONAL
Nickel Alloys	Inconel 600, 706, 718,	-	80 - 150	.004 - .017		2	1		3		YES
Titanium	903, Hastelloy	-	115 - 195	.004 - .017		2	1		3		YES

FormMaster R - Series 1DE1H, DE6H					Feed per Insert			Coolant	
Material	Brinnell Hardness	SFM	RNLU1205 MON-S	RNLU1205 MON-M	IN2505	IN6530	IN2530		
Cast Iron	Gray	150 - 250	500 - 800	.007 - .020	.015 - .035	2	1		No
	Nodular		450 - 800						
Steel	Low Carbon 1018, 8620	150 - 250	500 - 700	.007 - .020	.015 - .035	1	3	2	No
	High Carbon F-6180	250 - 400	450 - 500	.007 - .020	.015 - .040	1	3	2	
	Alloyed Steel 4140	150 - 300							
	Tool Steel P20 - H13	Up to 300							
Stainless Steel	300 Series, 304, 316	Up to 320	250 - 500	.005 - .015	.010 - .020	2	3	1	Yes
	400 Series 15-5 PH, 17-4 PH								
	13-8 PH								
Nickel Alloys	Inconel 600, 706, 718, 903, Hastelloy	-	50 - 250	.003 - .015	.003 - .012	2	3	1	Yes
Titanium	6AL-4V	-	50 - 250	.003 - .008	.003 - .008	2		1	Yes

Note: Feed and speed recommendations are starting operating parameters. They are only guidelines from which further optimization should take place. Operating parameters are influenced by many machining variables. These variables may cause for reductions in feeds and speed or dramatic increases. Additionally, DOC and WOC may need to be revised to optimize the tools performance.

FinishBall - Series 12A9, 12A5, 12A8					IN2005	IN2006	IN055	Coolant
Material		Brinnell Hardness	SFM	Feed per Insert				
Aluminum	6061-T6, 7075-T6	-	1000 - 8000	.003 - .006	2		1	Yes
Cast Iron	Gray	150 - 250	500 - 1200	.002 - .006	1			No
	Nodular		400 - 800					
Steel	Low Carbon 1018, 8620	150 - 250	600 - 1200	.002 - .006	1			No
	High Carbon F-6180	250 - 400*	400 - 600	.002 - .005	2	1		
	Alloyed Steel 4140	150 - 300	400 - 800		1	2		
	Tool Steel P20 - H13	Up to 460*			2	1		
Stainless Steel	300 Series, 304, 316	-	400 - 800	.002 - .005	1	2		No
	400 Series 15-5 PH, 17-4 PH	Up to 320	500-1000					Yes
	13-8 PH	-	200 - 400					
Nickel Alloys	Inconel 600, 706, 718, 903, Hastelloy	75-120	75-120	.002 - .004	1	2		Yes
Titanium	6AL-4V	-	80 - 150	.002 - .005	1	2		Yes

*58 Rc & Above use IN2006

Pro-Trio - Series 2TW7K					IN2505	IN2530	IN6530	Coolant
Material		Brinnell Hardness	SFM	Feed per Insert				
Cast Iron	Gray	-	785-1250	.004-.020	1	2	3	No
	Nodular		590-940					
Steel	Low Carbon 1018, 8620	85-175	650-1150	.004-.020	1	2	3	No
	High Carbon F-6180	175-225	590-1050	.004-.016				
	Alloyed Steel 4140	275-325	390-820	.002-.014				
	Tool Steel P20 - H13	200-250	330-660	.006-.016				
Stainless Steel	300 Series, 304, 316	-	590-918	.003-.014	2	1	3	No
	400 Series 15-5 PH, 17-4 PH	-	650-985	.002-.018				Yes
	13-8 PH	-	200-400	.003-.015				
Nickel Alloys	Inconel 600, 706, 718, 903, Hastelloy	-	65-265	.002-.008	2	1	3	Yes
Titanium	6AL-4V	-	130-360	.002-.012	2	1	3	Yes

*58 Rc & Above use IN2006

GoldMax4FFin - Series EF6J		Brinnell Hardness	SFM	Feed per Insert	IN2505	IN2530	IN4015	IN4030	Coolant
Material									
Cast Iron	Gray	150 - 250	800 - 1200	.025 - .050	2		1		No
	Nodular		500 - 900						
Steel	Carbon Steel 1018, A-36, 1045	100 - 250	600 - 900	.025 - .050	1	3		2	No
	Alloyed Steel 4140, 4340, 8620		500 - 800						
	Tool Steel A2, 01, P20, H13	200 - 400							
Stainless Steel	Free Machining 303, 416	150 - 250	500 - 800	.025 - .050	3	2		1	Yes
	300 Series, 304, 316		300 - 500						
	400 Series 15-5 PH	200 - 400							
	13-8 PH								
Nickel Alloys	Inconel 600, 706, 718, 903, Hastelloy, Waspalloy	200 - 350	75-150	.010 - .030	3	2		1	Yes
Titanium	6AL-4V, Ti-10-2-3, Ti-5553	250 - 450	75 - 200	.020 - .040	3	2		1	Yes

GoldMax 8 - Series VJ6V		Brinnell Hardness	SFM	Feed per Insert	IN2030	IN2530	IN4030	Coolant
Material								
Aluminum	6061-T6, 7075-T6, 2024	-	1500 - 8000	.004 - .016	1			Yes
Cast Iron	Gray	150 - 250	400 - 750	.004 - .012	2	3	1	No
	Nodular		300 - 650					
Steel	Low Carbon 1018, 8620	100 - 250	350 - 650	.004 - .012	2	3	1	No
	High Carbon F-6180	250 - 400	300 - 600	.004 - .008				
	Alloyed Steel 4140, 4340	150 - 300	250 - 500	.004 - .008				
	Tool Steel A2, 01, D2, P20	Up to 300						
Stainless Steel	300 Series, 304, 316	-	250 - 450	.004 - .010	2	3	1	May not be required at high speeds
	400 Series, 15-5 PH	Up to 320	300 - 600					
	13-8 PH	-	200 - 400					Yes
Nickel Alloys	Inconel, Hastelloy, Waspalloy	-	75-120	.003 - .006	2	3	1	Yes
Titanium	6-4, 10-2-3, 5-5-5-3	-	75 - 200	.003 - .006	2	3	1	Yes

*IN6515 preferred for higher SFM

GoldMax4 - Series 3EJ6_					IN2515	IN4015	IN2505	IN4005	IN2530	IN4030	IN2540	IN4040	Coolant
Material	Brinnell Hardness	SFM	Feed per Insert										
Cast Iron	Gray	150 - 280	400 - 750	.003 - .010	2	1		3					No
	Nodular		300 - 650										
Steel	Low Carbon 1018, 8620	100 - 250	250 - 500	.003 - .010									No
	High Carbon F-6180	250 - 400	200 - 350										
	Alloyed Steel 4140, 4340	150 - 300	250 - 400										
	Tool Steel A2, 01, D2, P20	Up to 300											
Stainless Steel	300 Series, 304, 316	-	400 - 600	.003 - .008				3	2	1			Yes
	400 Series, 15-5 PH	Up to 320	300 - 600										
	13-8 PH	-	200 - 600										
Nickel Alloys	Inconel 600, 706, 718, 903, Hastelloy, Waspalloy	-	75 - 150	.003 - .005				3	2	1			Yes
Titanium	6-4, 10-2-3, 5-5-5-3	-	75 - 150	.003 - .008				3	2	1			Yes

ThinMax - Series 3VJ5V					Feed per Insert WOC		IN2505	IN2515	IN2530	IN4005	IN4015	IN4030	Coolant
Material	Brinnell Hardness	SFM	.125"-.156"	.187"-.375"									
Aluminum	6062 T-6, 70705 T6	-	1500-1800	.004 - .008	.006 - .015		1						Yes
Cast Iron	Gray	150 - 250	400 - 750	.002 - .006	.004 - .010		2				1		No
	Nodular		300 - 650										
Steel	Low Carbon 1018, 8620	100 - 250	250 - 500	.002 - .006	.004 - .010	2		4	1		3		No
	High Carbon F-6180, Nitralloy 52100	250 - 400	250 - 350										
	Alloyed Steel 4140, 4340, 6150	150 - 300	250 - 400										
	Tool Steel A2, 01, D2, P20	Up to 300											
Stainless Steel	300 Series, 304, 316	-	250 - 400	.002 - .006	.004 - .010	4		2	3		1		Yes
	400 Series 15-5 PH, 17-4 PH	Up to 320	300 - 600										
	13-8 PH	-	200 - 250										
Nickel Alloys	Inconel 600, 706, 718, 903, Hastelloy, Waspalloy	-	75-120	.002 - .006	.004 - .010	4		2	3		1		Yes
Titanium	6AL-4V	-	100 - 150	.002 - .006	.004 - .010	4		2	3		1		Yes



GOLD RUSH GRADES

The ingenious solution that takes cutting tool materials to another level

Features

- Excellent surface finish on the workpiece
- Improved coating adhesion and insert chipping resistance
- Stable and extended tool life in continuous and interrupted cutting operations
- Reduced cutting friction and minimized built-up edge on exotic materials

Benefit of new cutting edge technology

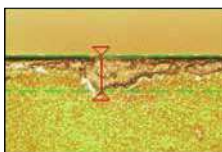

Improved

Material: 0.2% Carbon Steel (HB145-160)

Insert: CNMG 432 TT8115

Cutting Condition

V=330 sfm

f=.004 ipr

d=.120"

Facing, Interrupted cut

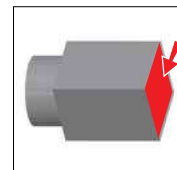

GOLD RUSH GRADES FOR STEEL APPLICATIONS

TT8115 (CVD)	P05	—	P25
<ul style="list-style-type: none"> • For high speed continuous turning on steels • Excellent wear and heat-resistance 			
TT8125 (CVD)	P15	—	P35
<ul style="list-style-type: none"> • For a wide range of steel turning applications • Very good combination of wear resistance and toughness • For general use on steels 			
TT5100 (CVD)	P20	—	P40
<ul style="list-style-type: none"> • For a wide range of turning operations on mild steel, low carbon steel and low carbon alloy steels • Excellent chipping and sticking resistance 			
TT8135 (CVD)	P25	—	P40
<ul style="list-style-type: none"> • Tough carbide substrate with good fracture resistance • For a wide range of medium to roughing applications at low cutting speed on steels • For heavy turning 			
TT7100 (CVD)	P30	—	P45
<ul style="list-style-type: none"> • Very tough carbide substrate base with a CVD coating • Excellent toughness and chipping resistance • For heavy turning 			

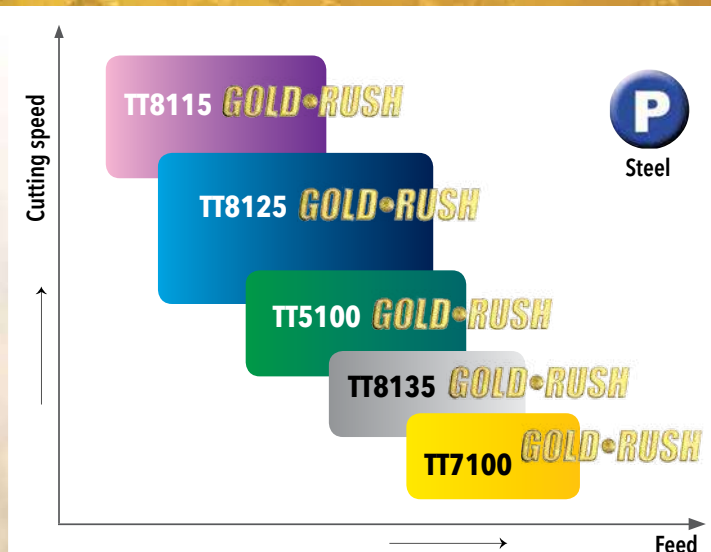

GOLD RUSH GRADES FOR STAINLESS STEELS AND HIGH-TEMP ALLOY APPLICATIONS

TT5080 (PVD)	M05	—	M15
	S05	—	S15
<ul style="list-style-type: none"> • For turning a wide range of high-temp alloys • Very hard submicron substrate with good fracture toughness 			
TT9215 (CVD)	M10	—	M25
	S10	—	S25
<ul style="list-style-type: none"> • Excellent wear resistance • For high cutting speed & continuous cutting on stainless steels 			
TT9080 (PVD)	M10	—	M30
	S15	—	S25
<ul style="list-style-type: none"> • For general machining of stainless steels and high-temp alloys • Submicron substrate with good fracture toughness 			
TT9225 (CVD)	M20	—	M35
	S20	—	S35
<ul style="list-style-type: none"> • Good combination of insert wear resistance & fracture toughness • For general use on stainless steels • Suitable for continuous and interrupted cutting on stainless steels 			
TT9235 (CVD)	M30	—	M45
	S30	—	S45
<ul style="list-style-type: none"> • Excellent fracture resistance & toughness • For low cutting speed & interrupted cutting on stainless steels 			

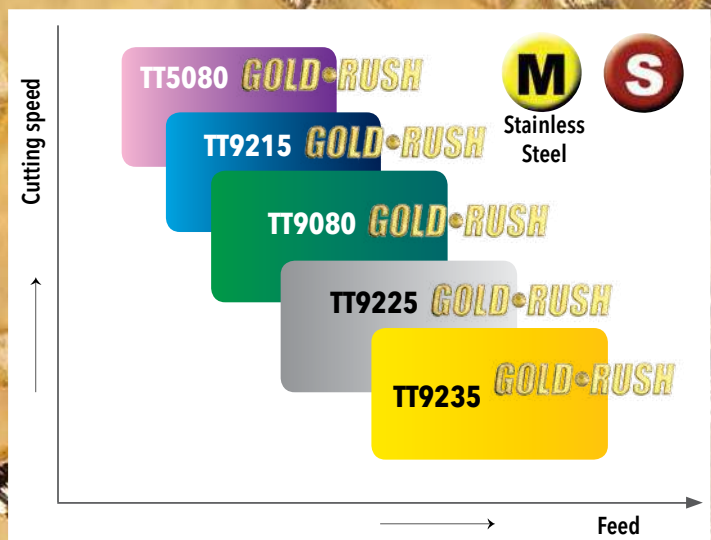

BLACKRUSH

New!

TURNING GRADES FOR HIGH SPEED MACHINING OF CAST IRON AND ALLOY STEEL

- Special "Black Rush" alumina CVD coating eliminates flaking and crater wear.
- Post coat surface treatment reduces build up and provides longer, more consistent tool life.

New!

- Positive chip breakers for alloy steel applications.
- "KT" chip breaker for interrupted cuts in cast iron.

TT7005

K05 — K15
P05 — P15

For High Speed Machining of Gray & Ductile Cast Iron & Alloy Steel

TT7015

K10 — K25
P10 — P20

For General Machining of Gray & Ductile Cast Iron & Alloy Steel



All BLACKRUSH inserts feature a new coating technology which contains a special Al₂O₃ outer layer that maximizes hardness while providing thermal stability, an important consideration when machining cast iron especially at high cutting speeds. Following this alumina coating process, a special surface treatment is applied that greatly reduces friction, cutting force and build-up on the insert cutting edge. The result is stable and consistent tool life and an excellent surface finish on the work piece.



104

FINE GOLD 2013/2014

INSERTS

	ANSI DESCRIPTION	ISO DESCRIPTION	Grade	
			TT7005	TT7015
NEW! CCMT21.51FG	CCMT21.51FG	CCMT060204FG	•	•
CCMT21.51MT	CCMT21.51MT	CCMT060204MT	•	•
CCMT21.52MT	CCMT21.52MT	CCMT060208MT	•	•
CCMT32.51FG	CCMT32.51FG	CCMT09T304FG	•	•
CCMT32.51MT	CCMT32.51MT	CCMT09T304MT	•	•
CCMT32.52FG	CCMT32.52FG	CCMT09T308FG	•	•
CCMT32.52MT	CCMT32.52MT	CCMT09T308MT	•	•
CCMT32.52WT	CCMT32.52WT	CCMT09T308WT	•	•
CCMT431MT	CCMT431MT	CCMT120404MT	•	•
CCMT432FG	CCMT432FG	CCMT120408FG	•	•
CCMT432MT	CCMT432MT	CCMT120408MT	•	•
CCMT433MT	CCMT433MT	CCMT120412MT	•	•
CNMA431	CNMA431	CNMA120404	•	•
CNMA432	CNMA432	CNMA120408	•	•
CNMA432WT	CNMA432WT	CNMA120408WT	•	•
CNMA433	CNMA433	CNMA120412	•	•
CNMA434	CNMA434	CNMA120416	•	•
CNMA543	CNMA543	CNMA160612	•	•
CNMA544	CNMA544	CNMA160616	•	•
CNMA642	CNMA642	CNMA190608	•	•
CNMA643	CNMA643	CNMA190612	•	•
CNMA644	CNMA644	CNMA190616	•	•
CNMG322	CNMG322	CNMG090308	•	•
CNMG322MT	CNMG322MT	CNMG090308MT	•	•
CNMG431	CNMG431	CNMG120404	•	•
NEW! CNMG431FG	CNMG431FG	CNMG120404FG	•	•
CNMG431MT	CNMG431MT	CNMG120404MT	•	•
CNMG432	CNMG432	CNMG120408	•	•
NEW! CNMG432FG	CNMG432FG	CNMG120408FG	•	•
NEW! CNMG432KT	CNMG432KT	CNMG120408KT	•	•
CNMG432MC	CNMG432MC	CNMG120408MC	•	•
NEW! CNMG432MP	CNMG432MP	CNMG120408MP	•	•
CNMG432MT	CNMG432MT	CNMG120408MT	•	•
CNMG432RT	CNMG432RT	CNMG120408RT	•	•
CNMG432WT	CNMG432WT	CNMG120408WT	•	•
CNMG433	CNMG433	CNMG120412	•	•
NEW! CNMG433KT	CNMG433KT	CNMG120412KT	•	•
CNMG433MT	CNMG433MT	CNMG120412MT	•	•
CNMG433RT	CNMG433RT	CNMG120412RT	•	•
CNMG433WT	CNMG433WT	CNMG120412WT	•	•
NEW! CNMG434KT	CNMG434KT	CNMG120416KT	•	•
CNMG434RT	CNMG434RT	CNMG120416RT	•	•
CNMG542MT	CNMG542MT	CNMG160608MT	•	•
CNMG543MT	CNMG543MT	CNMG160612MT	•	•
CNMG543RT	CNMG543RT	CNMG160612RT	•	•
CNMG544RT	CNMG544RT	CNMG160616RT	•	•
CNMG642	CNMG642	CNMG190608	•	•

	ANSI DESCRIPTION	ISO DESCRIPTION	Grade	
			TT7005	TT7015
CNMG642MT	CNMG642MT	CNMG190608MT	•	•
CNMG642RT	CNMG642RT	CNMG190608RT	•	•
CNMG643	CNMG643	CNMG190612	•	•
CNMG643MT	CNMG643MT	CNMG190612MT	•	•
CNMG643RT	CNMG643RT	CNMG190612RT	•	•
CNMG644RT	CNMG644RT	CNMG190616RT	•	•
CNMM432RH	CNMM432RH	CNMM120408RH	•	•
NEW! CPMT21.51PC	CPMT21.51PC	CPMT060204PC	•	•
NEW! CPMT21.52PC	CPMT21.52PC	CPMT060208PC	•	•
NEW! CPMT32.51PC	CPMT32.51PC	CPMT09T304PC	•	•
NEW! CPMT32.52PC	CPMT32.52PC	CPMT09T308PC	•	•
NEW! DCMT32.51FG	DCMT32.51FG	DCMT11T304FG	•	•
DCMT32.51MT	DCMT32.51MT	DCMT11T304MT	•	•
NEW! DCMT32.52FG	DCMT32.52FG	DCMT11T308FG	•	•
DCMT32.52MT	DCMT32.52MT	DCMT11T308MT	•	•
DCMT32.53MT	DCMT32.53MT	DCMT11T312MT	•	•
DNMA432	DNMA432	DNMA150408	•	•
DNMA433	DNMA433	DNMA150412	•	•
DNMA442	DNMA442	DNMA150608	•	•
DNMA443	DNMA443	DNMA150612	•	•
DNMG332MT	DNMG332MT	DNMG110408MT	•	•
DNMG333MT	DNMG333MT	DNMG110412MT	•	•
DNMG431	DNMG431	DNMG150404	•	•
NEW! DNMG431FG	DNMG431FG	DNMG150404FG	•	•
DNMG431MT	DNMG431MT	DNMG150404MT	•	•
DNMG432	DNMG432	DNMG150408	•	•
NEW! DNMG432FG	DNMG432FG	DNMG150408FG	•	•
NEW! DNMG432KT	DNMG432KT	DNMG150408KT	•	•
DNMG432MT	DNMG432MT	DNMG150408MT	•	•
DNMG432RT	DNMG432RT	DNMG150408RT	•	•
DNMG432WS	DNMG432WS	DNMG150408WS	•	•
DNMG433	DNMG433	DNMG150412	•	•
NEW! DNMG433KT	DNMG433KT	DNMG150412KT	•	•
DNMG433MT	DNMG433MT	DNMG150412MT	•	•
DNMG433RT	DNMG433RT	DNMG150412RT	•	•
DNMG441	DNMG441	DNMG150604	•	•
DNMG441MT	DNMG441MT	DNMG150604MT	•	•
DNMG442	DNMG442	DNMG150608	•	•
NEW! DNMG442KT	DNMG442KT	DNMG150608KT	•	•
DNMG442MT	DNMG442MT	DNMG150608MT	•	•
DNMG442RT	DNMG442RT	DNMG150608RT	•	•
DNMG443	DNMG443	DNMG150612	•	•
NEW! DNMG443KT	DNMG443KT	DNMG150612KT	•	•
DNMG443MT	DNMG443MT	DNMG150612MT	•	•
DNMG443RT	DNMG443RT	DNMG150612RT	•	•
HNMG432GU	HNMG432GU	HNMG050408GU	•	•
HNMG643GU	HNMG643GU	HNMG100612GU	•	•

• Marked : Standard item

INSERTS

ANSI DESCRIPTION	ISO DESCRIPTION	Grade	
		TT7005	TT7015
KNUX3331R11	KNUX160405R11	•	•
RCMT10T300MT	RCMT10T300MT	•	•
RCMT120400MT	RCMT120400MT	•	•
RCMT160600MT	RCMT160600MT	•	•
RCMX100300	RCMX100300	•	•
RCMX120400	RCMX120400	•	•
RCMX160600	RCMX160600	•	•
RCMX200600	RCMX200600	•	•
RCMX250700	RCMX250700	•	•
RCMX250700	RCMX250700	•	•
RCMX250700MT	RCMX250700MT	•	•
RCMX320900	RCMX320900	•	•
SCMT32.51MT	SCMT09T304MT	•	•
SCMT32.52MT	SCMT09T308MT	•	•
SCMT431MT	SCMT120404MT	•	•
SCMT432MT	SCMT120408MT	•	•
SCMT433MT	SCMT120412MT	•	•
SNMA432	SNMA120408	•	•
SNMA433	SNMA120412	•	•
SNMA434	SNMA120416	•	•
SNMA543	SNMA150612	•	•
SNMA544	SNMA150616	•	•
SNMA643	SNMA190612	•	•
SNMA644	SNMA190616	•	•
SNMA856	SNMA250724	•	•
SNMG431	SNMG120404	•	•
SNMG432	SNMG120408	•	•
new! SNMG432KT	SNMG120408KT	•	•
SNMG432MT	SNMG120408MT	•	•
SNMG432RT	SNMG120408RT	•	•
SNMG433	SNMG120412	•	•
new! SNMG433KT	SNMG120412KT	•	•
SNMG433MT	SNMG120412MT	•	•
SNMG433RT	SNMG120412RT	•	•
SNMG543RT	SNMG150612RT	•	•
SNMG642	SNMG190608	•	•
SNMG643	SNMG190612	•	•
SNMG643RT	SNMG190612RT	•	•
SPG421	SPGN120304	•	•
TCMT21.51MT	TCMT110204MT	•	•
new! TCMT21.52FG	TCMT110208FG	•	•
TCMT21.52MT	TCMT110208MT	•	•
new! TCMT32.51FG	TCMT16T304FG	•	•
TCMT32.51MT	TCMT16T304MT	•	•
new! TCMT32.52FG	TCMT16T308FG	•	•
TCMT32.52MT	TCMT16T308MT	•	•
TCMT32.53MT	TCMT16T312MT	•	•

ANSI DESCRIPTION	ISO DESCRIPTION	Grade	
		TT7005	TT7015
TCMT731MT	TCMT090204MT	•	•
TCMT732MT	TCMT090208MT	•	•
TNMA331	TNMA160404	•	•
TNMA332	TNMA160408	•	•
TNMA333	TNMA160412	•	•
TNMA334	TNMA160416	•	•
TNMA432	TNMA220408	•	•
TNMA433	TNMA220412	•	•
TNMA434	TNMA220416	•	•
TNMG331	TNMG160404	•	•
TNMG331MT	TNMG160404MT	•	•
TNMG332	TNMG160408	•	•
new! TNMG332KT	TNMG160408KT	•	•
TNMG332MT	TNMG160408MT	•	•
TNMG332RT	TNMG160408RT	•	•
new! TNMG333KT	TNMG160412KT	•	•
TNMG333MT	TNMG160412MT	•	•
TNMG333RT	TNMG160412RT	•	•
TNMG431	TNMG220404	•	•
TNMG432	TNMG220408	•	•
new! TNMG432KT	TNMG220408KT	•	•
TNMG432MT	TNMG220408MT	•	•
TNMG432RT	TNMG220408RT	•	•
TNMG433	TNMG220412	•	•
new! TNMG433KT	TNMG220412KT	•	•
TNMG433RT	TNMG220412RT	•	•
TNMG434	TNMG220416	•	•
TPG322	TPGN160308	•	•
TPMR732	TPMR090208	•	•
TPMR221	TPMR110304	•	•
TPMR222	TPMR110308	•	•
TPMR321	TPMR160304	•	•
TPMR322	TPMR160308	•	•
TPMR432	TPMR220408	•	•
new! TPMT21.51PC	TPMT110204PC	•	•
new! TPMT21.52PC	TPMT110208PC	•	•
TPMT221FG	TPMT110304FG	•	•
new! VBMT331FG	VBMT160404FG	•	•
VBMT331MT	VBMT160404MT	•	•
new! VBMT332FG	VBMT160408FG	•	•
VBMT332MT	VBMT160408MT	•	•
VBMT333MT	VBMT160412MT	•	•
VNMG2.531MT	VNMG130404MT	•	•
VNMG2.532MT	VNMG130408MT	•	•
VNMG331	VNMG160404	•	•
new! VNMG331FG	VNMG160404FG	•	•
VNMG332	VNMG160408	•	•

INSERTS

ANSI DESCRIPTION	ISO DESCRIPTION	Grade	
		TT7005	TT7015
NEW! VNMG332FG	VNMG160408FG	•	•
VNMG332MT	VNMG160408MT	•	•
VNMG333	VNMG160412	•	•
WNMA332	WNMA060408	•	•
WNMA333	WNMA060412	•	
WNMA432	WNMA080408	•	•
WNMA433	WNMA080412	•	•
WNMA434	WNMA080416	•	•
WNMG331MT	WNMG060404MT	•	•
WNMG332MT	WNMG060408MT	•	
WNMG332WT	WNMG060408WT	•	
WNMG333MT	WNMG060412MT	•	
WNMG333WT	WNMG060412WT		•
WNMG431	WNMG080404	•	•
WNMG431MT	WNMG080404MT	•	•
WNMG432	WNMG080408	•	•
NEW! WNMG432FG	WNMG080408FG	•	•
NEW! WNMG432KT	WNMG080408KT	•	•
NEW! WNMG432MP	WNMG080408MP	•	•
WNMG432MT	WNMG080408MT	•	•
WNMG432RT	WNMG080408RT	•	•
WNMG432WT	WNMG080408WT	•	•
WNMG433	WNMG080412	•	•
NEW! WNMG433KT	WNMG080412KT	•	•
WNMG433MT	WNMG080412MT	•	•
WNMG433RT	WNMG080412RT	•	•
WNMG433WT	WNMG080412WT	•	•
WNMG434RT	WNMG080416RT	•	

• Marked : Standard item

TOTURN™

CERAMIC GRADE

TC430 WHISKER REINFORCED CERAMIC GRADE FOR MACHINING HIGH STRENGTH AND HIGH TEMPERATURE ALLOY MATERIAL

- SiC whisker reinforced ceramics grade.
- High hardness and high fracture toughness.
- Suitable for general turning and milling applications.
- Excellent for high speed cutting of Ni-based superalloys (Inconel, Waspaloy, Rene, etc.), hardened steels and hard castings

MICROSTRUCTURE

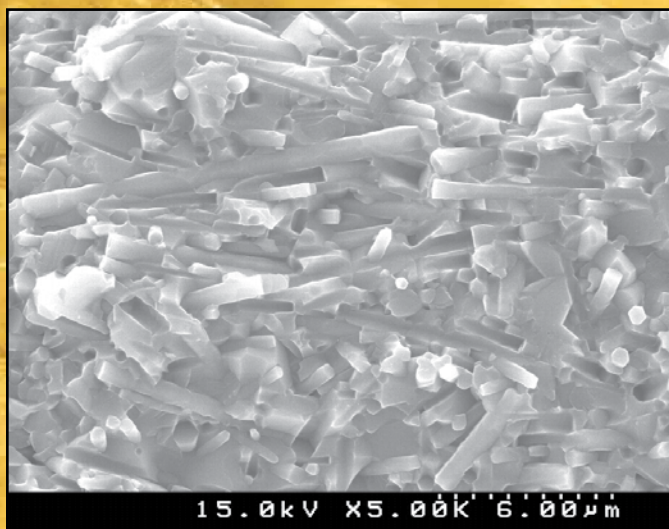

PHYSICAL PROPERTIES

Density	Hardness (Hv)	Fracture Toughness, KIC
3.7	2,050 ~ 2,100	4.5 ~ 5.5

RECOMMENDED CUTTING CONDITIONS FOR HIGH TEMPERATURE ALLOYS

Density	V(sfm)	F(ipr)
Turning	500-1300	.004-.012
Milling	1300-3280	.004-.008

APPLICATION RANGE

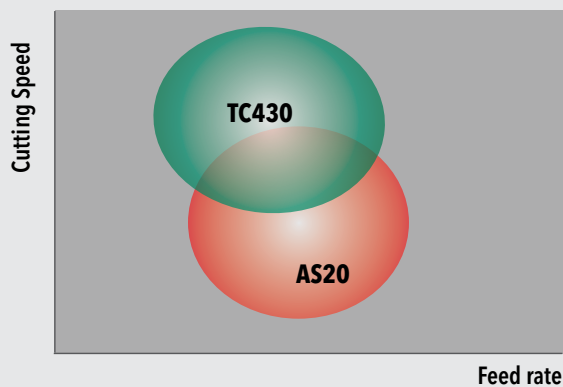

CNG T6

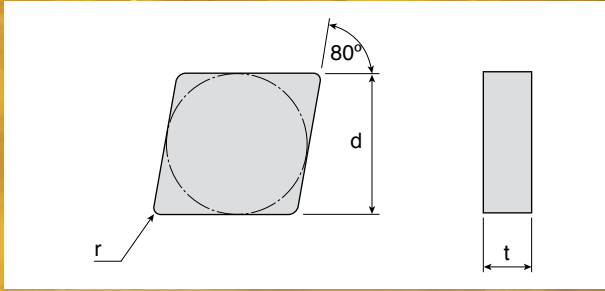

ANSI Number	ISO Number	Dimensions (inch)			Grade	TC430
		d	t	r		
CNG 432 T6	CNGN 120408 T6	.500	.187	.031		•
CNG 433 T6	CNGN 120412 T6	.500	.187	.047		•
CNG 452 T6	CNGN 120708 T6	.500	.312	.031		•
CNG 453 T6	CNGN 120712 T6	.500	.312	.047		•

RCGX T6

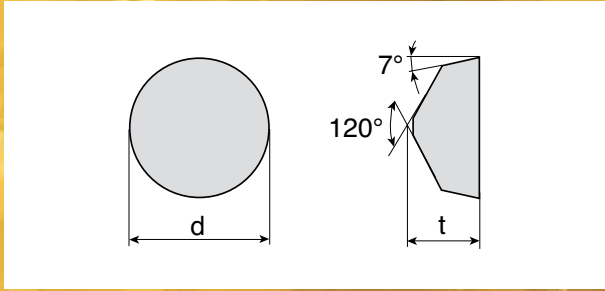

ANSI Number	ISO Number	Dimensions (inch)			Grade	TC430
		d	t	r		
RCGX 35 T6	RCGX 090700 T6	.375	.315	-		•
RCGX 45 T6	RCGX 120700 T6	.500	.315	-		•

RNG T6

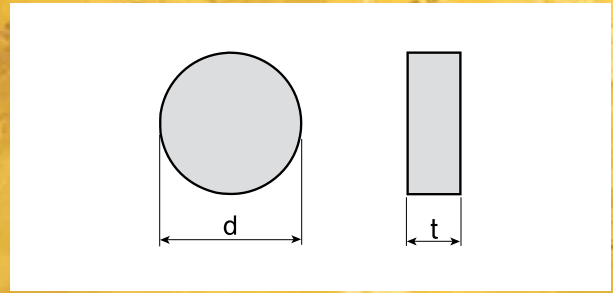

ANSI Number	ISO Number	d	t	r	Grade	TC430
RNG 32 T6	RNGN 090300 T6	.375	.125	-		•
RNG 43 T6	RNGN 120400 T6	.500	.187	-		•
RNG 45 T6	RNGN 120700 T6	.500	.312	-		•
RNG 65 T6	RNGN 190700 T6	.750	.312	-		•

RPG T6

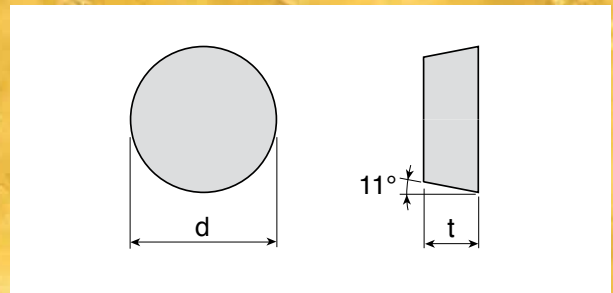

ANSI Number	ISO Number	d	t	r	Grade	TC430
RPG 43 T6	RPGN 120400 T6	.500	.187	-		•

RPGX T6

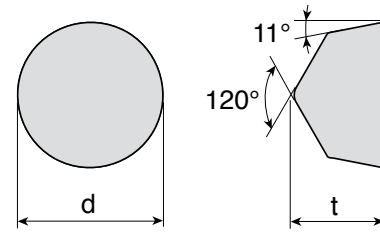

ANSI Number	ISO Number	d	t	r	Grade	TC430
RPGX 35 T6	RPGX 090700 T6	.375	.312	-		•
RPGX 45 T6	RPGX 120700 T6	.500	.312	-		•

SNG T6

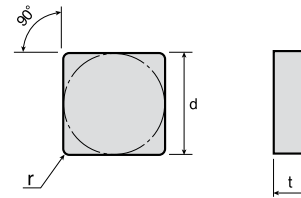
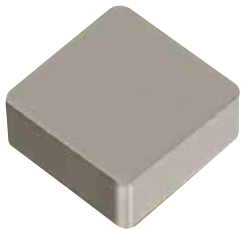

ANSI Number	ISO Number	Dimensions (inch)			Grade	TC430
		d	t	r		
SNG 432 T6	SNGN 120408 T6	.500	.187	.031		•
SNG 433 T6	SNGN 120412 T6	.500	.187	.047		•
SNG 452 T6	SNGN 120708 T6	.500	.312	.031		•
SNG 453 T6	SNGN 120712 T6	.500	.312	.047		•

TOTURN™

CBN GRADES

TB610, TB670, TB730

EXCELLENT CUTTING PERFORMANCE IN HARDENED STEEL AND CAST IRON



TB610

- Excellent oxidation resistance and chemical stability.
- For continuous to light interrupted turning.
- For machining hard steel, alloy steel, tool steel and case hardened steel.

TB670

- High hardness and impact resistance.
- For continuous to severe interrupted turning.
- For alloy steel, tool steel, case hardened steel and chilled cast iron.

TB730

- High hardness and high fracture toughness.
- General turning and milling.
- For gray cast iron, nodular cast iron and carbide rolls.

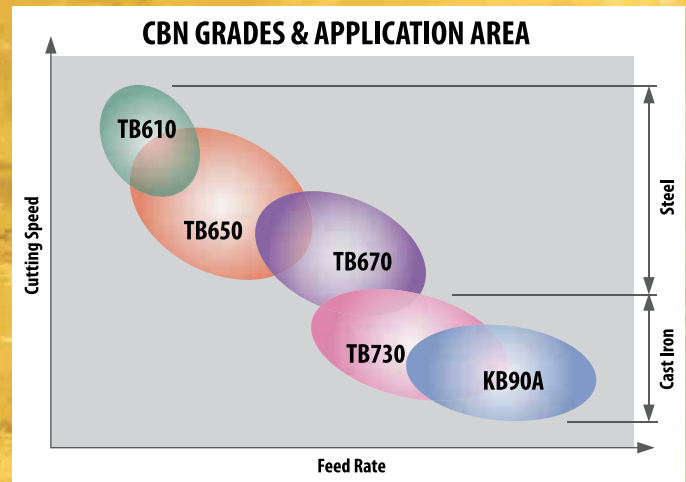

RECOMMENDED CUTTING CONDITIONS

Materials		TB610	TB670	TB730
Gray Cast Iron (HB 180-230)	V (sfm)			1640 - 3280
	f (ipr)			.004 - .012
Chilled Cast Iron (> HB 400)	V (sfm)		260 - 490	260 - 490
	f (ipr)		.004 - .008	.004 - .012
Hardened Steel (HRc 40-65)	V (sfm)	490 - 1150	330 - 980	
	f (ipr)	.002 - .008	.004 - .012	
Sintered Metal (Hv 200-600)	V (sfm)		330 - 980	330 - 820
	f (ipr)		.002 - .008	.004 - .010
DCI or HSS Roll	V (sfm)		650 - 1640	
	f (ipr)		.002 - .008	
Super Alloy (Ni-base)	V (sfm)			330 - 980
	f (ipr)			.002 - .008

■ CCGW CBN

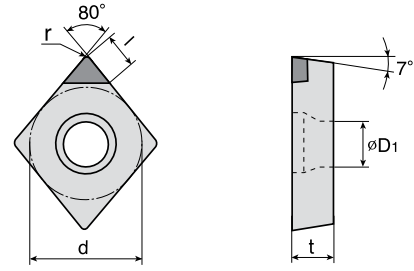

ANSI DESIGNATION	ISO DESIGNATION	Dimension (inches)					D1	Grade	TB610	TB670	TB730
		l	d	t	r						
CCGW 21.50.5LS2	CCGW 060202 LS2	.087	.250	.094	.008	.110			●	●	●
CCGW 21.51LS2	CCGW 060204 LS2	.083	.250	.094	.016	.110		○	●	●	●
CCGW 21.52LS2	CCGW 060208 LS2	.083	.250	.094	.031	.110		○	●	●	●
CCGW 32.51LS2	CCGW 09T304 LS2	.094	.375	.157	.016	.173		○	●	●	●
CCGW 32.51WZ-LS2	CCGW 09T304 WZ-LS2	.094	.375	.157	.016	.173		○	●	●	●
CCGW 32.52LS2	CCGW 09T308 LS2	.091	.375	.157	.031	.173		○	●	●	●
CCGW 32.52WZ-LS2	CCGW 09T308 WZ-LS2	.091	.375	.157	.031	.173			●	●	●
CCGW 431LS2	CCGW 120404 LS2	.083	.500	.187	.016	.216					●
CCGW 432LS2	CCGW 120408 LS2	.083	.500	.187	.031	.216					●

LS2 - Insert with 2 tips WZ - Insert with wiper geometry

■ CNGA CBN

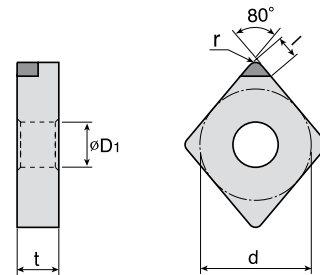

ANSI DESIGNATION	ISO DESIGNATION	Dimension (inches)					D1	Grade	TB610	TB670	TB730
		l	d	t	r						
CNGA 431WZ-LS2	CNGA 120404 WZ-LS2	.083	.500	.187	.016	.203		○	●		
CNGA 431WZ-LS4	CNGA 120404 WZ-LS4	.083	.500	.187	.016	.203			●		
CNGA 432WZ-LS2	CNGA 120408 WZ-LS2	.083	.500	.187	.031	.203		○	●	●	●
CNGA 432WZ-LS4	CNGA 120408 WZ-LS4	.083	.500	.187	.031	.203		○	●	●	●
CNGA 433WZ-LS2	CNGA 120412 WZ-LS2	.098	.500	.187	.047	.203			●	●	●
CNGA 433WZ-LS4	CNGA 120412 WZ-LS4	.098	.500	.187	.047	.203			●		●

LS2 - Insert with 2 tips LS4 - Insert with 4 tips WZ - Insert with wiper geometry

■ CNMA CBN - LN/LS

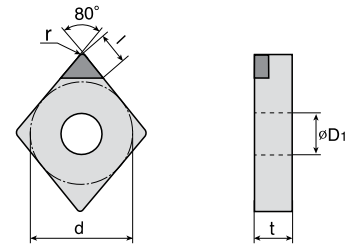

ANSI DESIGNATION	ISO DESIGNATION	Dimension (inches)						Grade	TB610	TB670	TB730
		l	d	t	r	D1					
CNMA 431LN	CNMA 120404 LN	.165	.500	.188	.016	.203	○	○	○	○	
CNMA 431LN2	CNMA 120404 LN2	.165	.500	.188	.016	.203	○	○	○	●	
CNMA 431LS2	CNMA 120404 LS2	.087	.500	.188	.016	.203	○	○	○	●	
CNMA431LS4	CNMA 120404 LS4	.087	.500	.188	.016	.203	○	○	○	●	
CNMA 432LN	CNMA 120408 LN	.157	.500	.188	.031	.203	○	○	○	●	
CNMA 432LS2	CNMA 120408 LS2	.083	.500	.188	.031	.203	○	○	○	●	
CNMA 432LS4	CNMA 120408 LS4	.083	.500	.188	.031	.203	○	○	○	●	
CNMA433LN	CNMA 120412 LN	.154	.500	.188	.047	.203	○	○	○	●	
CNMA433LS2	CNMA 120412 LS2	.098	.500	.188	.047	.203	○	○	○	●	
CNMA 433LS4	CNMA 120412 LS4	.098	.500	.188	.047	.203	○	○	○	●	

LN - Insert with longer tip LS2 - Insert with 2 tips LS4 - Insert with 4 tips

■ DCGW CBN - LS

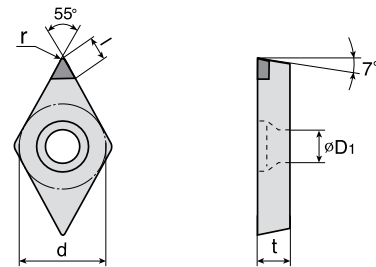

ANSI DESIGNATION	ISO DESIGNATION	Dimension (inches)						Grade	TB610	TB670	TB730
		l	d	t	r	D1					
DCGW21.50.5LS2	DCGW 070202 LS2	.102	.250	.094	.008	.110	○	○	○	○	
DCGW21.51LS2	DCGW 070204LS2	.094	.250	.094	.016	.110	○	○	○	●	
DCGW21.52LS2	DCGW 070208 LS2	.083	.250	.094	.031	.110	○	○	○	●	
DCGW32.51LS2	DCGW 11T304 LS2	.102	.375	.157	.016	.173	○	○	○	●	
DCGW32.52LS2	DCGW 11T308 LS2	.087	.375	.157	.031	.173	○	○	○	●	

LS2 - Insert with 2 tips

■ DNMA - LN/LS

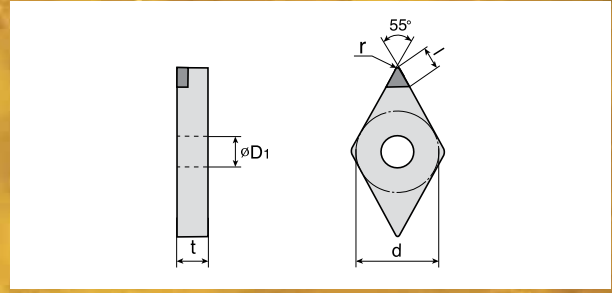
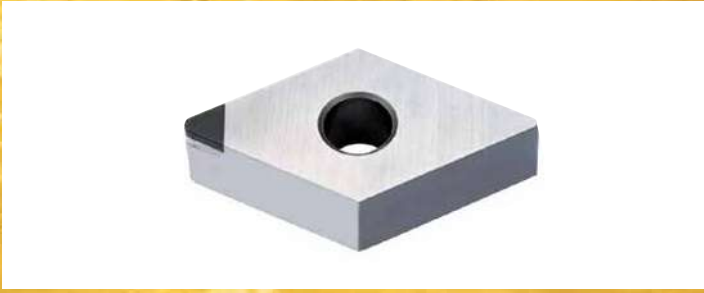

ANSI DESIGNATION	ISO DESIGNATION	Dimension (inches)						Grade	TB610	TB670	TB730
		l	d	t	r	D1					
DNMA 431LN	DNMA 150404 LN	.165	.500	.187	.016	.203	○	◐	◑	◒	
DNMA 431LS2	DNMA 150404 LS2	.102	.500	.187	.016	.203	○	◐	◑	◒	
DNMA 431LS4	DNMA 150404 LS4	.102	.500	.187	.016	.203	○	◐	◑	◒	
DNMA 432LN	DNMA 150408 LN	.154	.500	.187	.031	.203	○	◐	◑	◒	
DNMA 432LS2	DNMA 150408 LS2	.102	.500	.187	.031	.203	○	◐	◑	◒	
DNMA 432LS4	DNMA 150408 LS4	.091	.500	.187	.031	.203	○	◐	◑	◒	
DNMA 433LN	DNMA 150412 LN	.138	.500	.187	.047	.203	○	◐	◑	◒	
DNMA 433LS2	DNMA 150412 LS2	.087	.500	.187	.047	.203			◐	◑	
DNMA 433LS4	DNMA 150412 LS4	.087	.500	.187	.047	.203			◐	◑	
DNMA 441LN	DNMA 150604 LN	.165	.500	.250	.016	.203	○	◐	◑	◒	
DNMA 441LS2	DNMA 150604 LS2	.102	.500	.250	.016	.203	○	◐	◑	◒	
DNMA 442LN	DNMA 150608 LN	.154	.500	.250	.031	.203	○	◐	◑	◒	
DNMA 442LS2	DNMA 150608 LS2	.091	.500	.250	.031	.203	○	◐	◑	◒	
DNMA 442LS4	DNMA 150608 LS4	.091	.500	.250	.031	.203			◐	◑	
DNMA 443LS2	DNMA 150612 LS2	.087	.500	.250	.047	.203	○	◐	◑	◒	

LN - Insert with longer tip LS2 - Insert with 2 tips LS4 - Insert with 4 tips

RCGX CBN

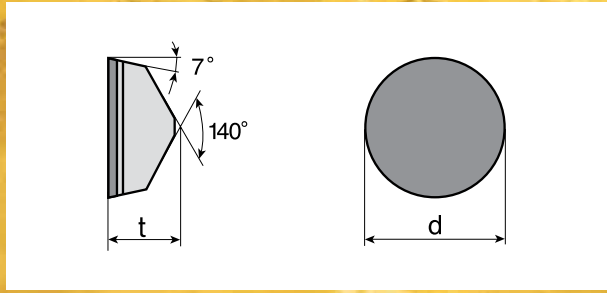

ANSI DESIGNATION	ISO DESIGNATION	Dimensions (inches)						Grade	TB610	TB670	TB730
		l	d	t	r	D1					
RCGX 22FT	RCGX 060300 FT	-	.250	.125	-	-				●	
RCGX 32FT	RCGX 090300 FT	-	.375	.125	-	-				●	
RCGX 43FT	RCGX 120400 FT	-	.500	.187	-	-				●	

FT - Full top CBN

RNMN FT

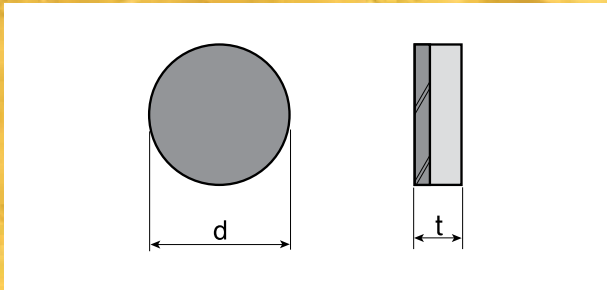

ANSI DESIGNATION	ISO DESIGNATION	Dimension (inches)						Grade	TB610	TB670	TB730
		l	d	t	r	D1					
RNMN32FT	RNMN 090300 FT	-	.375	.125	-	-				●	

FT - Full top CBN

■ SCGW CBN

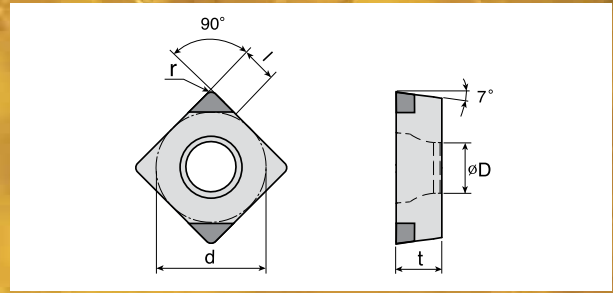
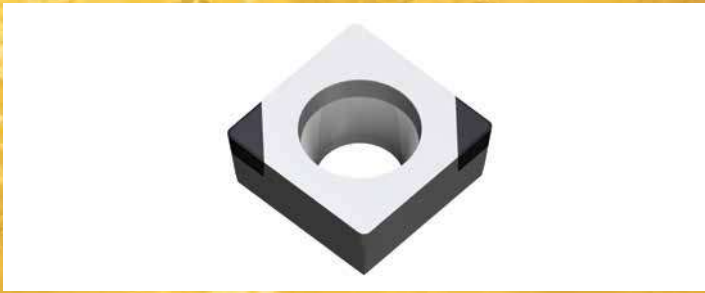

ANSI DESIGNATION	ISO DESIGNATION	Dimension (inches)					D1	Grade	TB610	TB670	TB730
		l	d	t	r						
SCGW 32.51LS2	SCGW 09T304 LS2	.106	.375	.157	.016	.173					●
SCGW 32.52LS2	SCGW 09T308 LS2	.106	.375	.157	.031	.173					●

LS2 - Insert with 2 tips

■ SNMA CBN

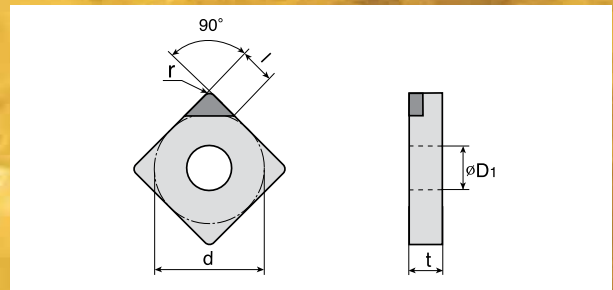

ANSI DESIGNATION	ISO DESIGNATION	Dimension (inches)					D1	Grade	TB610	TB670	TB730
		l	d	t	r						
SNMA 431LN	SNMA 120404 LN	.165	.500	.187	.016	.203					●
SNMA 431LS2	SNMA 120404 LS2	.098	.500	.187	.016	.203					●
SNMA 431LS4	SNMA 120404 LS4	.098	.500	.187	.016	.203					●
SNMA 432LN	SNMA 120408 LN	.165	.500	.187	.031	.203		○	●		●
SNMA 432LS2	SNMA 120408 LS2	.098	.500	.187	.031	.203		○	●		●
SNMA 432LS4	SNMA 120408 LS4	.098	.500	.187	.031	.203					●
SNMA 432LS8	SNMA 120408 LS8	.098	.500	.187	.031	.203					●

LN - Insert with longer tip LS2 - Insert with 2 tips LS4 - Insert with 4 tips LS8 - Insert with 8 tips

TCGW LS

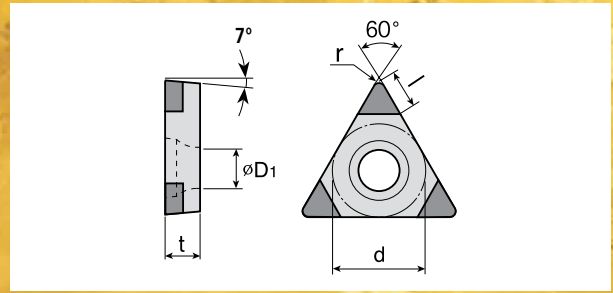
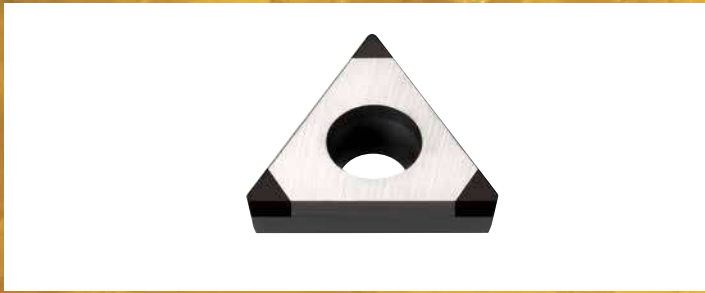

ANSI DESIGNATION	ISO DESIGNATION	Dimensions (inches)					D1	Grade	TB610	TB670	TB730
		l	d	t	r						
TCGW 731LS3	TCGW 090204 LS3	.090	.219	.094	.016	.098	○	◐	◑	●	
TCGW 732LS3	TCGW 090208 LS3	.082	.219	.094	.031	.098			◐	◑	
TCGW 21.51LS3	TCGW 110204 LS3	.090	.250	.094	.016	.110	○	◐	◑	●	
TCGW 21.52LS3	TCGW 110208 LS3	.090	.250	.094	.031	.110			◐	◑	●
TCGW 32.51LS3	TCGW 16T304 LS3	.082	.375	.157	.016	.173	○	◐	◑	●	
TCGW 32.52LS3	TCGW 16T308 LS3	.082	.375	.157	.031	.173	○	◐	◑	●	

LS3 - Insert with 3 tips

TNMA CBN

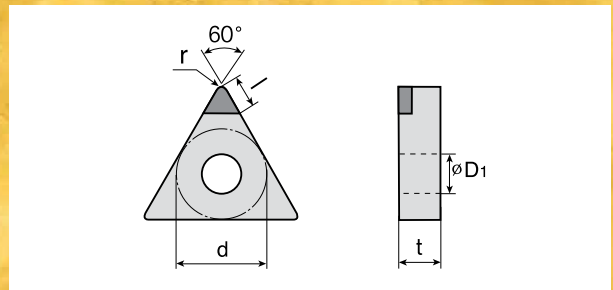

ANSI DESIGNATION	ISO DESIGNATION	Dimension (inches)					D1	Grade	TB610	TB670	TB730
		l	d	t	r						
TNMA 331LN	TNMA 160404 LN	.169	.375	.187	.016	.150			◐	◑	
TNMA 331LS3	TNMA 160404 LS3	.086	.375	.187	.016	.150	○	◐	◑	●	
TNMA 331LS6	TNMA 160404 LS6	.086	.375	.187	.016	.150			◐	◑	
TNMA 332LN	TNMA 160408 LN	.157	.375	.187	.031	.150			◐	◑	
TNMA 332LS3	TNMA 160408 LS3	.082	.375	.187	.031	.150	○	◐	◑	●	
TNMA 332LS6	TNMA 160408 LS6	.082	.375	.187	.031	.150			◐	◑	
TNMA 333LS3	TNMA 160412 LS3	.100	.375	.187	.047	.150			◐	◑	●

LN - Insert with longer tip LS3 - Insert with 3 tips LS6 - Insert with 6 tips

TPG LS

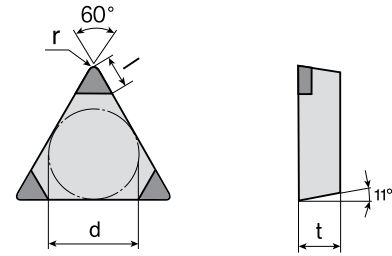
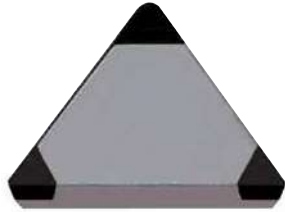

ANSI DESIGNATION	ISO DESIGNATION	Dimensions (inches)						Grade	TB610	TB670	TB730
		l	d	t	r	D1					
TPG 731LS3	TPGN 090204 LS3	.090	0.219	0.094	0.016	-		○			
TPG 2205 LS3	TPGN 110302 LS3	.110	0.250	0.125	0.008	-				●	
TPG 221 LS3	TPGN 110304 LS3	.102	0.250	0.125	0.016	-		○	◐	●	
TPG 222 LS3	TPGN 110308 LS3	.090	0.250	0.125	0.031	-		○	◐	●	
TPG 321 LS3	TPGN 160304 LS3	.110	0.375	0.125	0.016	-		○	◐	●	
TPG 322 LS3	TPGN 160308 LS3	.100	0.375	0.125	0.031	-		○	◐	●	

LS3 - Insert with 3 tips

TPGW CBN

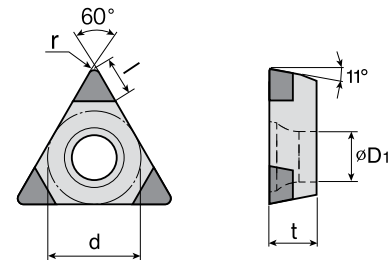

ANSI DESIGNATION	ISO DESIGNATION	Dimensions (inches)						Grade	TB610	TB670	TB730
		l	d	t	r	D1					
TPGW631LS3	TPGW080204LS3	.082	.187	.094	.016	.098			◐		
TPGW731LS3	TPGW090204LS3	.090	.219	.094	.016	.098			◐	●	
TPGW732LS3	TPGW090208LS3	.078	.219	.094	.031	.098			◐		
TPGW220.5LS3	TPGW110302LS3	.110	.250	.125	.008	.134		○		●	
TPGW221LS	TPGW110304LS	.102	.250	.125	.016	.134			◐		
TPGW221LS3	TPGW110304LS3	.102	.250	.125	.016	.134		○		●	
TPGW222LS3	TPGW110308LS3	.090	.250	.125	.031	.134		○	◐	●	
TPGW331LS3	TPGW160404LS3	.110	.375	.187	.016	.173			◐		
TPGW332LS3	TPGW160408LS3	.100	.375	.187	.031	.173			◐		

LS3 - Insert with 3 tips

VBGW CBN

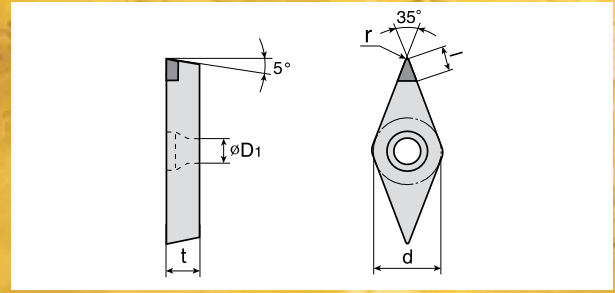
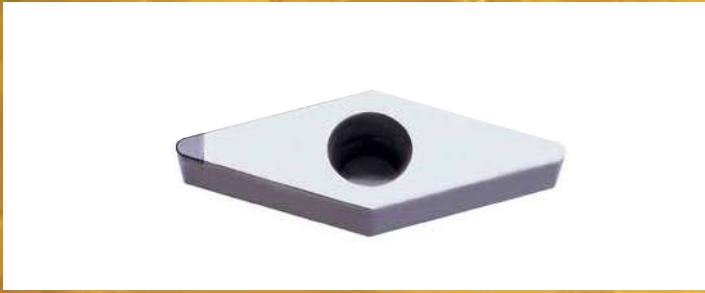

ANSI DESIGNATION	ISO DESIGNATION	Dimensions (inches)					D1	Grade	TB610	TB670	TB730
		l	d	t	r						
VBGW 222LS2	VBGW 110308 LS2	.094	.250	.125	.031	.110	○	○	○	●	
VBGW 332LS2	VBGW 160408 LS2	.090	.375	.187	.031	.173	○	○	○	●	

LS2 - Insert with 2 tips

VNGA CBN

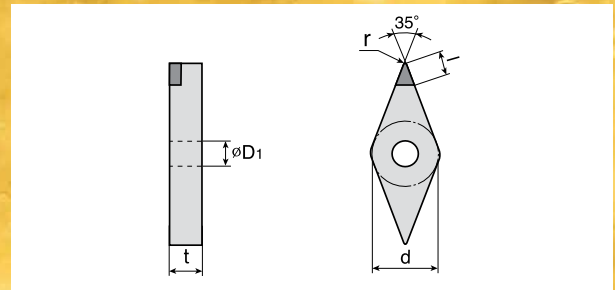

ANSI DESIGNATION	ISO DESIGNATION	Dimensions (inches)					D1	Grade	TB610	TB670	TB730
		l	d	t	r						
VNGA 331LN	VNGA 160404 LN	.197	.375	.187	.016	.150		○	○	○	
VNGA 331LS2	VNGA 160404 LS2	.126	.375	.187	.016	.150		○	○	●	
VNGA 332LN	VNGA 160408 LN	.161	.375	.187	.031	.150		○	○	○	
VNGA 332LS2	VNGA 160408 LS2	.094	.375	.187	.031	.150		○	○	●	
VNGA 332LS4	VNGA 160408 LS4	.094	.375	.187	.031	.150		○	○	●	

LN - Insert with longer tip LS2 - Insert with 2 tips LS4 - Insert with 4 tips

WNGA CBN

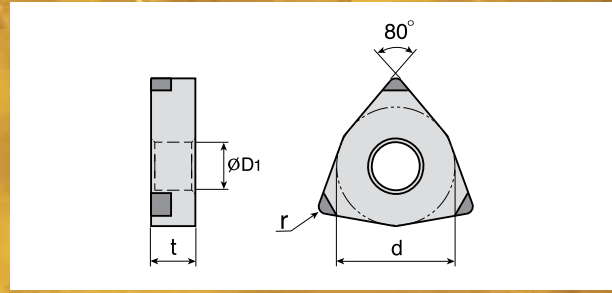

ANSI DESIGNATION	ISO DESIGNATION	Dimensions (inches)					D1	Grade	TB610	TB670	TB730
		l	d	t	r						
WNGA332WZ-LS6	WNGA060408WZ-LS6	.083	.375	.187	.031	.150					
WNGA432WZ-LS3	WNGA080408WZ-LS3	.083	.500	.187	.031	.203					
WNGA432WZ-LS6	WNGA080408WZ-LS6	.083	.500	.187	.031	.203					
WNGA433WZ-LS3	WNGA080412WZ-LS3	.083	.500	.187	.047	.203					

LS3 - Insert with 3 tips LS6 - Insert with 6 tips

WNMA CBN

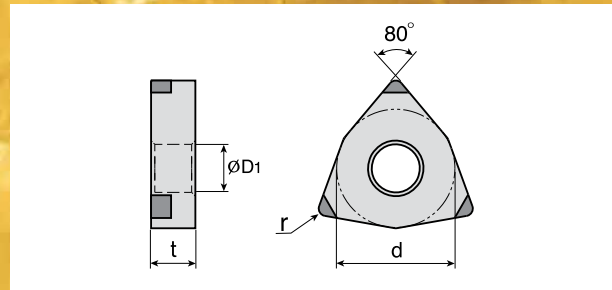

ANSI DESIGNATION	ISO DESIGNATION	Dimensions (inches)					D1	Grade	TB610	TB670	TB730
		l	d	t	r						
WNMA 432LS3	WNMA 080408 LS3	.083	.500	.187	.031	.203					
WNMA 432LS6	WNMA 080408 LS6	.083	.500	.187	.031	.203					

LS3 - Insert with 3 tips LS6 - Insert with 6 tips

TOTURN™

PCD CHIPBREAKER INSERT CB - PCD INSERT WITH SPECIAL TOP FACE GEOMETRY

- Serrated cutting edge ensures maximum chip control and low cutting resistance
- Performs remarkably well even in low depth of cut and low feed
- Unique cutting edge geometry guarantees excellent chipping resistance

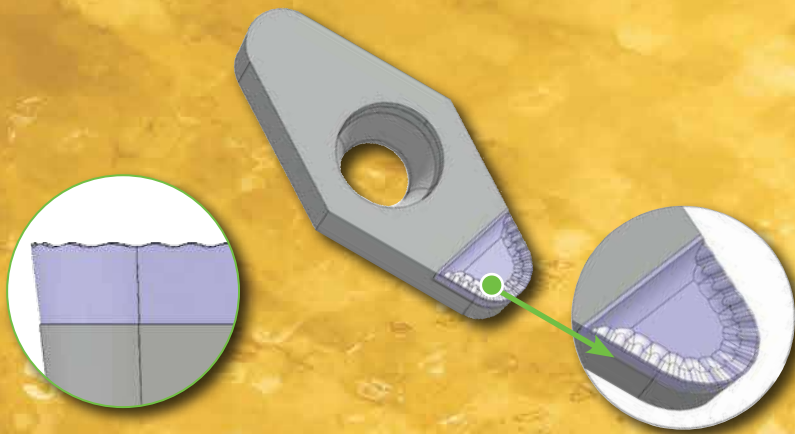

■ CCGT CB

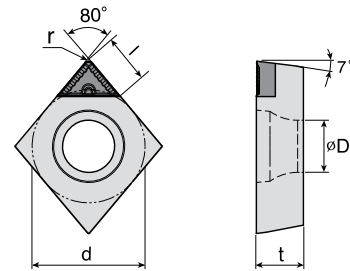
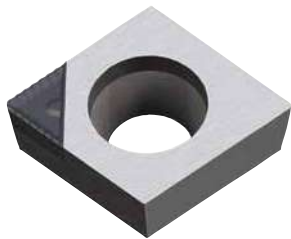

ANSI DESIGNATION	ISO DESIGNATION	Dimensions (inch)					Grade	KP300
		l	d	t	r	D1		
CCGT21.51CB	CCGT060204CB	0.122	0.250	0.094	0.016	0.110	●	
CCGT32.50.5CB	CCGT09T302CB	0.163	0.375	0.156	0.008	0.173	●	
CCGT32.51CB	CCGT09T304CB	0.161	0.375	0.156	0.016	0.173	●	
CCGT32.52CB	CCGT09T308CB	0.157	0.375	0.156	0.031	0.173	●	
CCGT431CB	CCGT120404CB	0.161	0.500	0.187	0.016	0.217	●	
CCGT432CB	CCGT120408CB	0.157	0.500	0.187	0.031	0.217	●	

DCGT CB

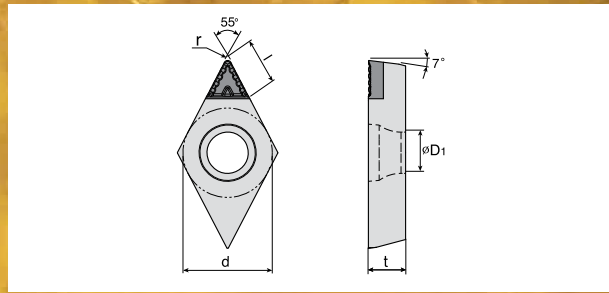
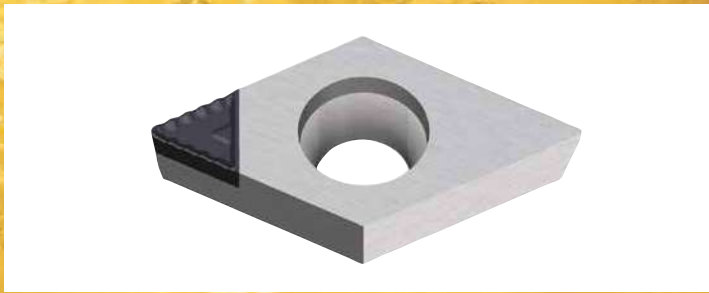

ANSI DESIGNATION	ISO DESIGNATION	Dimensions (inch)					D1	Grade	KP300
		l	d	t	r				
DCGT21.50.5CB	DCGT070202CB	0.134	0.250	0.094	0.008	0.110	●		
DCGT21.51CB	DCGT070204CB	0.130	0.250	0.094	0.016	0.110	●		
DCGT32.50.5CB	DCGT11T302CB	0.193	0.375	0.156	0.008	0.173	●		
DCGT32.51CB	DCGT11T304CB	0.185	0.375	0.156	0.016	0.173	●		
DCGT32.52CB	DCGT11T308CB	0.173	0.375	0.156	0.031	0.173	●		

TCGT CB

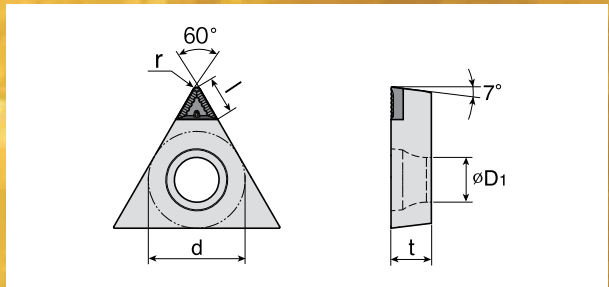

ANSI DESIGNATION	ISO DESIGNATION	Dimensions (inch)					D1	Grade	KP300
		l	d	t	r				
TCGT731CB	TCGT090204CB	0.110	0.219	0.094	0.016	0.098	●		
TCGT21.51CB	TCGT110204CB	0.150	0.250	0.094	0.016	0.173	●		
TCGT32.51CB	TCGT16T304CB	0.154	0.375	0.156	0.016	0.173	●		
TCGT32.52CB	TCGT16T308CB	0.142	0.375	0.156	0.031	0.173	●		

VCGT CB

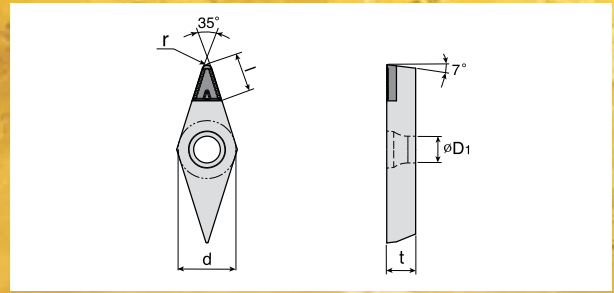
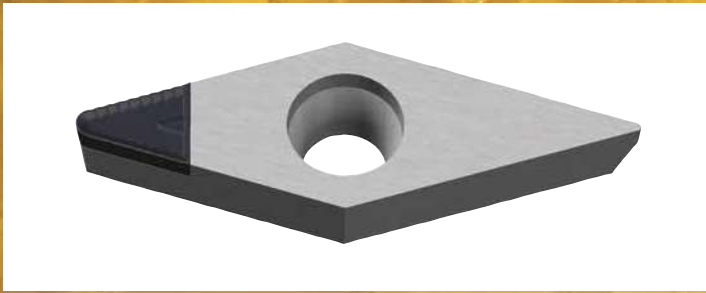

ANSI DESIGNATION	ISO DESIGNATION	Dimensions (inch)					D1	Grade	KP300
		l	d	t	r				
VCGT220.5CB	VCGT110302CB	0.185	0.250	0.125	0.008	0.110	●		
VCGT221CB	VCGT110304CB	0.197	0.250	0.125	0.016	0.110	●		
VCGT331CB	VCGT160404CB	0.287	0.375	0.187	0.016	0.150	●		
VCGT332CB	VCGT160408CB	0.252	0.375	0.187	0.031	0.150	●		
VCGT333CB	VCGT160412CB	0.244	0.375	0.187	0.047	0.150	●		
VCGT43.57.5CB	VCGT220530CB	0.252	0.500	0.219	0.118	0.217	●		



SAME PERFORMANCE AT 20-25% LOWER PRICE!

SMALL inserts with superior durability and the **SAME THICKNESS** as ISO inserts

ISO TURN
(CNMG 12)

TOTANK™



Actual size of insert



CNMG

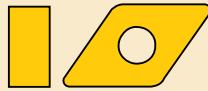

DNMG



SNMG



TNMG

Current trends in manufacturing feature work piece components with reduced stock conditions due to improved casting and forging technology. In these cases, depths of cut in rough turning are predominantly in the range of .040"~.080" per side, rendering conventional ISO turning inserts with .500" long cutting edges inefficient due to their disproportionate size.

In the modern machining environment with high focus on cost reduction, Ingersoll is pleased to launch T-Tank, a series of smaller, but robust, ISO turning inserts to meet the manufacturing industry's needs of reduced machining costs and increased competitiveness.

Excellent insert rigidity! Strong clamping holder! "Next generation clamping system"

Conventional ISO clamping structure

Single directional clamping force

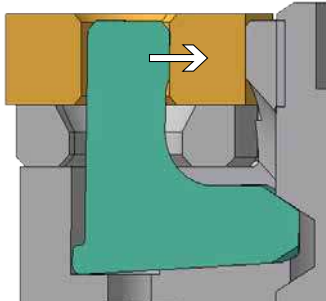

TOTANK™ clamping structure

Multi-directional clamping forces

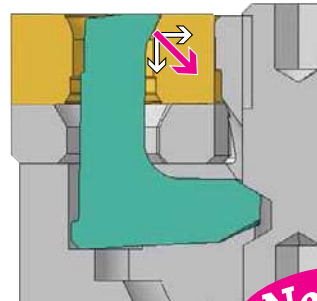

New



Features

- Exceptionally stable machining due to multi-directional clamping forces over the existing conventional ISO lever holder's single direction clamping force
- Excellent productivity and longer, stable tool life in high feed turning applications
- Optimal performance in interrupted cutting on weak/old machine set-ups

Detailed product marking

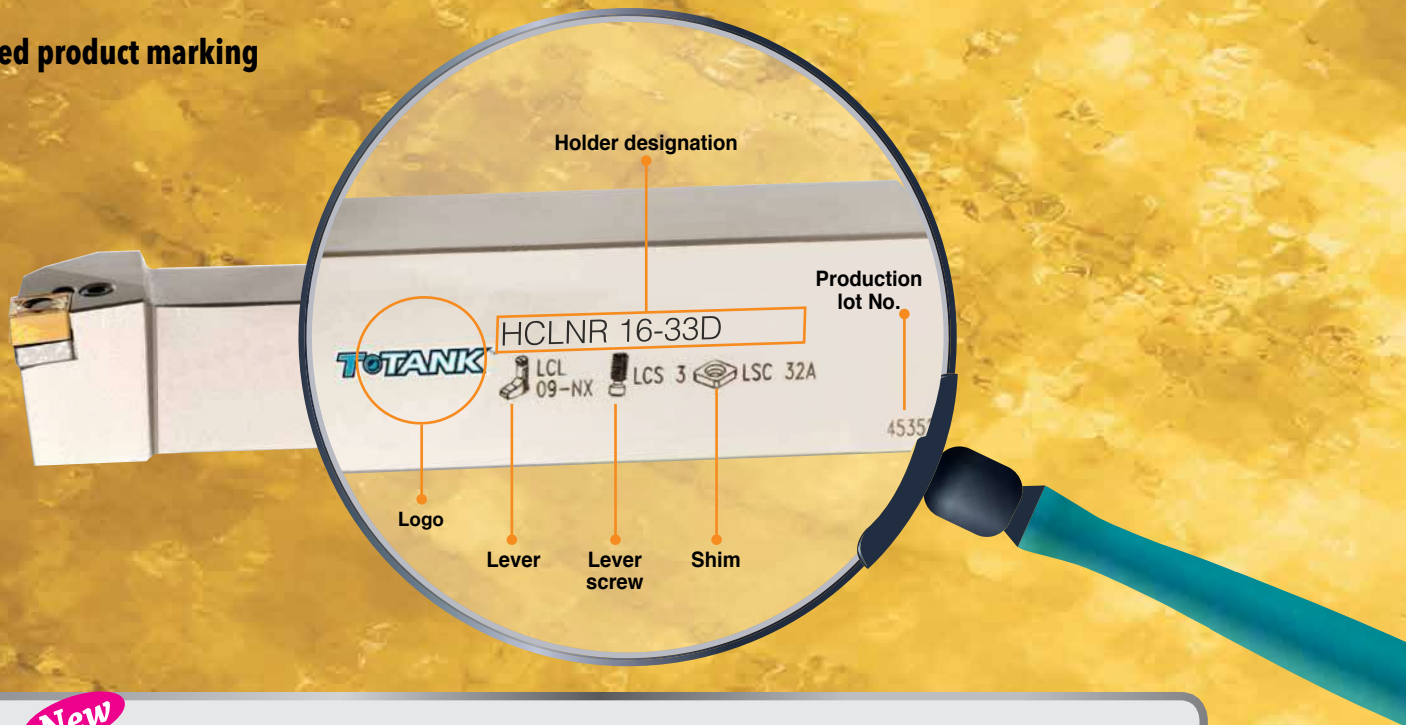

New

T•TANK holder vs. ISO standard holder tool life comparison test

Interrupted cut (Ingersoll tech center)

- Work piece: Medium carbon alloy steel
- Process: Interrupted facing
- Cutting condition: $V=330\text{sfm}$, $f=.024\text{ipr}$, $d=.160"$, Dry

Comparison test

- 1 CNMG 432 + PCLNR 2525 M12 holder (ISO standard holder)
- 2 CNMG 332 + HCLNR 16-33D (T•TANK holder)





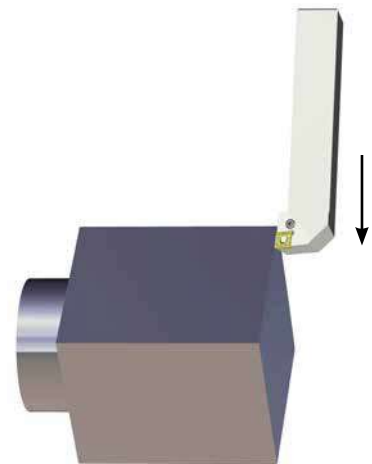
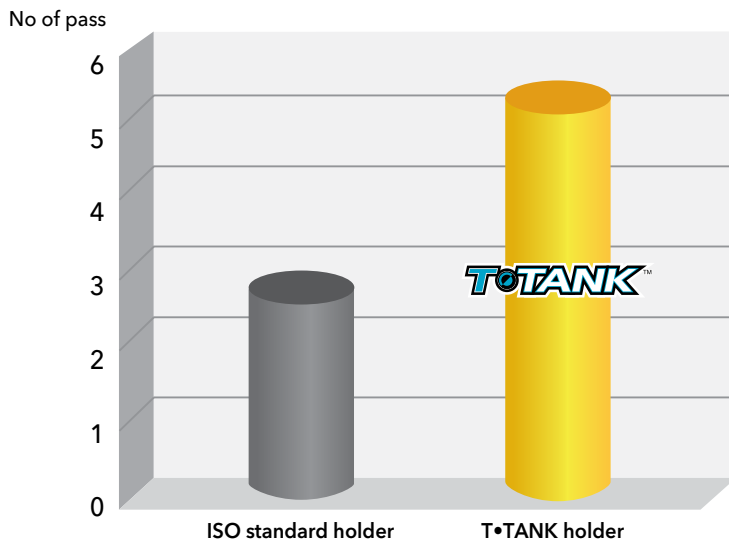

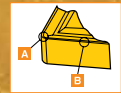





















* Chip breaker & grade are the same

Insert life



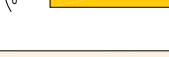

Chipbreakers

Chipbreaker		Range & Features	
FG		 	<ul style="list-style-type: none"> • For finishing and semi-finishing applications • For steel application • Low cutting forces
FM		 	<ul style="list-style-type: none"> • For steel machining • Solution for a wide range from semi-finishing to semi-medium machining
FT		 	<ul style="list-style-type: none"> • For steel machining • Strong, serrated cutting edge for excellent chip evacuation in wider depth of cut range for both profiling and step machining • Semi-finishing and medium machining • Excellent chip breaking for automotive components
PC		 	<ul style="list-style-type: none"> • For semi-finishing to medium applications • Ideal for Steel & Automotive components • Excellent chip control on medium applications
MT		 	<ul style="list-style-type: none"> • Suitable for continuous and interrupted cutting • For medium rough applications • Steel, cast iron and stainless steel • Tough rake angle for general use
EA		 	<ul style="list-style-type: none"> • For finishing applications • Exotic materials • Excellent chip control at low feeds and depths of cut
EM		 	<ul style="list-style-type: none"> • For medium applications • Stainless steel machining • Sharp land design for low cutting force
MM		 	<ul style="list-style-type: none"> • For general machining on stainless steel and steel • Positive rake angle provides excellent chip evacuation
MG-		 	<ul style="list-style-type: none"> • For medium rough applications • For general machining on cast iron • Strong rake geometry
TNGG			<ul style="list-style-type: none"> • Ground Insert • Suitable for general purpose machining • Lower cutting force and increased adhesion force • Improved dimension and finishing surface accuracy

Chipbreakers

Steel - Workpiece: Medium carbon steel / Cutting speed (Vc): 650 sfm

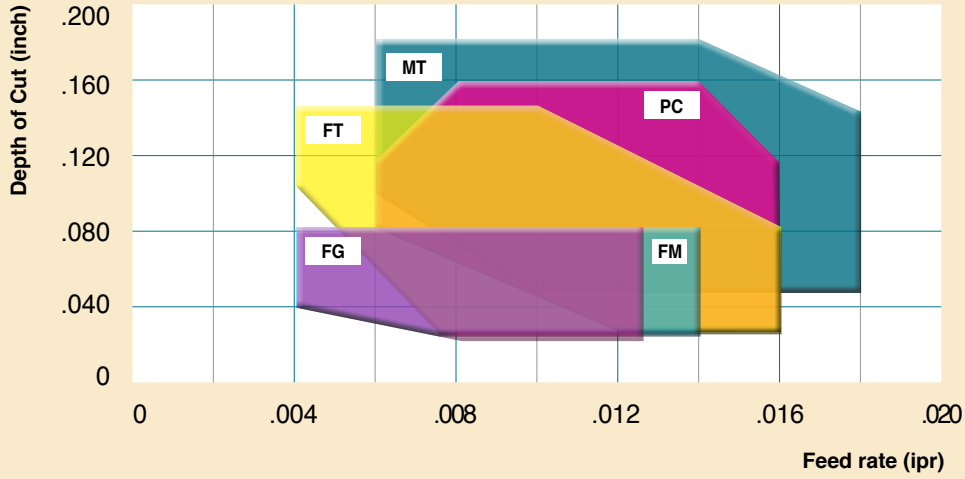

Stainless Steel - Workpiece: Stainless steel / Cutting speed (Vc): 650 sfm

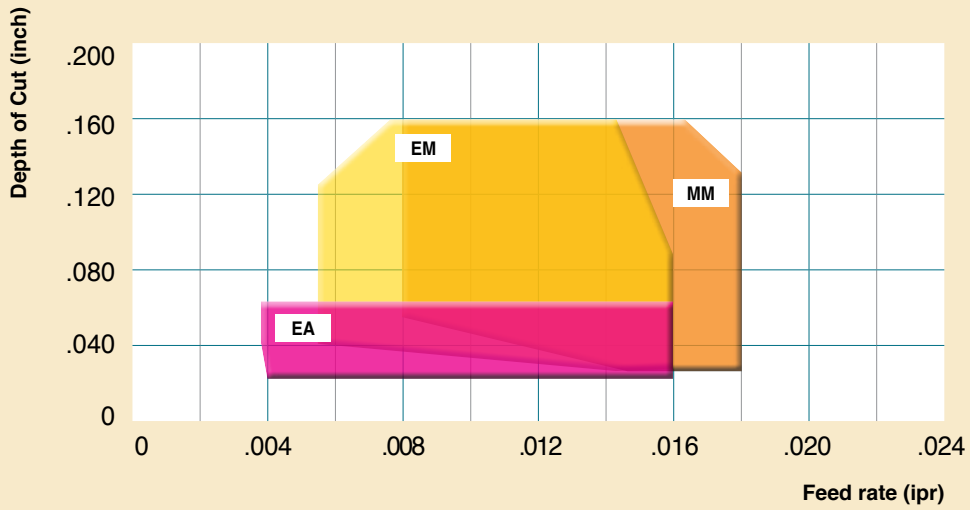

CNMG Negative 80° Rhombic Inserts

Designation	d	t	r
CNMG 331	0.375	0.187	0.016
CNMG 332	0.375	0.187	0.031
CNMG 333	0.375	0.187	0.047



Insert	Designation		Recommended Parameters		Grade												
	ANSI	ISO	feed (ipr)	ap (inch)	Cermet	CVD Coated										PVD Coated	
					CT3000	TT7005	TT7015	TT8115	TT8125	TT8135	TT9215	TT9225	TT9235	TT5100	TT5080	TT9080	
	CNMA332	CNMA090408	.006-.024	.039-.157		●	●										
	CNMA333	CNMA090412	.006-.028	.039-.157		●	●										
	CNMG331	CNMG090404	.004-.018	.020-.157		●	●										
	CNMG332	CNMG090408	.004-.020	.020-.157		●	●										
	CNMG333	CNMG090412	.004-.022	.020-.157		●	●										
	CNMG331EA	CNMG090404EA	.002-.012	.005-.059							●	●	●		●	●	
	CNMG332EA	CNMG090408EA	.003-.020	.006-.059							●	●	●		●	●	
	CNMG332EM	CNMG090404EM	.005-.020	.020-.157							●	●	●		●	●	
	CNMG333EM	CNMG090408EM	.006-.020	.028-.157							●	●	●		●	●	
	CNMG331FG	CNMG090404FG	.003-.012	.008-.079				●	●						●		
	CNMG332FG	CNMG090408FG	.004-.014	.020-.079				●	●						●		
	CNMG333FG	CNMG090412FG	.006-.016	.020-.079				●	●						●		
	CNMG331FM	CNMG090404FM	.003-.012	.010-.079	●			●	●	●					●		
	CNMG332FM	CNMG090408FM	.004-.014	.012-.079	●			●	●	●					●		
	CNMG333FM	CNMG090412FM	.006-.016	.014-.079	●			●	●	●					●		
	CNMG331FT	CNMG090404FT	.003-.012	.016-.138				●	●	●					●		
	CNMG332FT	CNMG090408FT	.004-.016	.020-.138				●	●	●					●		
	CNMG333FT	CNMG090412FT	.006-.020	.024-.138				●	●	●					●		
	CNMG331MM	CNMG090404MM	.006-.018	.016-.157				●	●	●	●	●	●	●	●		
	CNMG332MM	CNMG090408MM	.008-.020	.020-.157				●	●	●	●	●	●	●	●		
	CNMG333MM	CNMG090412MM	.009-.020	.028-.157				●	●	●	●	●	●	●	●		
	CNMG331MT	CNMG090404MT	.004-.014	.031-.177				●	●	●					●		
	CNMG332MT	CNMG090408MT	.006-.018	.039-.177				●	●	●					●		
	CNMG333MT	CNMG090412MT	.008-.022	.047-.177				●	●	●					●		
	CNMG331PC	CNMG090404PC	.004-.012	.016-.157				●	●	●					●		
	CNMG332PC	CNMG090408PC	.006-.016	.020-.157				●	●	●					●		
	CNMG333PC	CNMG090412PC	.007-.020	.024-.157				●	●	●					●		

DNMG Negative 55° Rhombic Inserts

Designation	d	t	r
DNMG 3.53.51	0.437	0.219	0.016
DNMG 3.53.52	0.437	0.219	0.031
DNMG 3.53.53	0.437	0.219	0.047

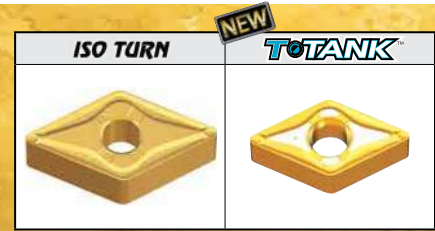

Insert	Designation		Recommended Parameters		Grade												
	ANSI	ISO	feed (ipr)	ap (inch)	CVD Coated												
					CT3000	TT7005	TT7015	TT8115	TT8125	TT8135	TT9215	TT9225	TT9235	TT15100	TT5080	TT9080	
	DNMG3.53.51	DNMG130504	.004-.018	.020-.157		•	•										
	DNMG3.53.52	DNMG130508	.004-.020	.020-.157		•	•										
	DNMG3.53.53	DNMG130512	.004-.022	.020-.157		•	•										
	DNMG3.53.51EA	DNMG130504EA	.002-.012	.005-.059							•	•	•		•	•	
	DNMG3.53.52EA	DNMG130508EA	.003-.016	.006-.059							•	•	•		•	•	
	DNMG3.53.52EM	DNMG130504EM	.005-.016	.020-.157							•	•	•		•	•	
	DNMG3.53.53EM	DNMG130508EM	.006-.016	.028-.157							•	•	•		•	•	
	DNMG3.53.51FG	DNMG130504FG	.003-.012	.008-.079				•	•						•		
	DNMG3.53.52FG	DNMG130508FG	.004-.014	.020-.079				•	•						•		
	DNMG3.53.53FG	DNMG130512FG	.006-.016	.020-.079				•	•						•		
	DNMG3.53.51FM	DNMG130504FM	.003-.012	.010-.079	•			•	•	•					•		
	DNMG3.53.52FM	DNMG130508FM	.004-.014	.012-.079	•			•	•	•					•		
	DNMG3.53.53FM	DNMG130512FM	.006-.016	.014-.079	•			•	•	•					•		
	DNMG3.53.51FT	DNMG130504FT	.003-.012	.010-.138				•	•	•					•		
	DNMG3.53.52FT	DNMG130508FT	.004-.016	.012-.138				•	•	•					•		
	DNMG3.53.53FT	DNMG130512FT	.006-.020	.014-.118				•	•	•					•		
	DNMG3.53.51MM	DNMG130504MM	.006-.018	.016-.177				•	•	•	•	•	•	•			
	DNMG3.53.52MM	DNMG130508MM	.008-.020	.020-.177				•	•	•	•	•	•	•			
	DNMG3.53.53MM	DNMG130512MM	.009-.020	.028-.177				•	•	•	•	•	•	•			
	DNMG3.53.51MT	DNMG130504MT	.004-.014	.031-.177				•	•	•					•		
	DNMG3.53.52MT	DNMG130508MT	.006-.018	.039-.177				•	•	•					•		
	DNMG3.53.53MT	DNMG130512MT	.008-.022	.047-.177				•	•	•					•		
	DNMG3.53.51PC	DNMG130504PC	.004-.012	.016-.157				•	•	•					•		
	DNMG3.53.52PC	DNMG130508PC	.006-.016	.020-.157				•	•	•					•		
	DNMG3.53.53PC	DNMG130512PC	.007-.020	.024-.157				•	•	•					•		

SNMG Negative 90° Square Inserts

Designation	d	t	r
SNMG 331	0.375	0.187	0.016
SNMG 332	0.375	0.187	0.031
SNMG 333	0.375	0.187	0.047



Insert	Designation		Recommended Parameters		Grade												
	ANSI	ISO	feed (mm/rev)	ap (mm)	Cermets		CVD Coated							PVD Coated			
					CT3000	TT7005	TT7015	TT8115	TT8125	TT8135	TT9215	TT9225	TT9235	TT5100	TT5080	TT9080	
	SNMG331	SNMG090404	.004-.018	.020-.157		●	●										
	SNMG332	SNMG090408	.004-.020	.020-.157		●	●										
	SNMG333	SNMG090412	.004-.022	.020-.157		●	●										
	SNMG331EA	SNMG090404EA	.002-.012	.005-.059							●	●	●		●	●	
	SNMG332EA	SNMG090408EA	.003-.016	.006-.059							●	●	●		●	●	
	SNMG332EM	SNMG090404EM	.005-.016	.020-.157							●	●	●		●	●	
	SNMG333EM	SNMG090408EM	.006-.016	.028-.157							●	●	●		●	●	
	SNMG331FG	SNMG090404FG	.003-.012	.008-.079				●	●						●		
	SNMG332FG	SNMG090408FG	.004-.014	.020-.079				●	●						●		
	SNMG333FG	SNMG090412FG	.006-.016	.020-.079				●	●						●		
	SNMG331FM	SNMG090404FM	.003-.012	.010-.079	●			●	●	●					●		
	SNMG332FM	SNMG090408FM	.004-.014	.012-.079	●			●	●	●					●		
	SNMG333FM	SNMG090412FM	.006-.016	.014-.079	●			●	●	●					●		
	SNMG331MM	SNMG090404MM	.006-.018	.016-.157				●	●	●	●	●	●	●	●		
	SNMG332MM	SNMG090408MM	.008-.020	.020-.157				●	●	●	●	●	●	●	●		
	SNMG333MM	SNMG090412MM	.009-.020	.028-.157				●	●	●	●	●	●	●	●		
	SNMG331MT	SNMG090404MT	.004-.014	.031-.157				●	●	●					●		
	SNMG332MT	SNMG090408MT	.006-.018	.039-.157				●	●	●					●		
	SNMG333MT	SNMG090412MT	.008-.022	.047-.157				●	●	●					●		
	SNMG331PC	SNMG090404PC	.004-.012	.016-.138				●	●	●					●		
	SNMG332PC	SNMG090408PC	.006-.016	.020-.138				●	●	●					●		
	SNMG333PC	SNMG090412PC	.007-.020	.024-.138				●	●	●					●		

TNMG Negative 60° Triangular Inserts

Designation	d	t	r
TNMG 2.531	0.313	0.187	0.016
TNMG 2.532	0.313	0.187	0.031
TNMG 2.533	0.313	0.187	0.047



Insert	Designation		Recommended Parameters		Grade												
	ANSI	ISO	feed (mm/rev)	ap (mm)	Cermet	CVD Coated									PVD Coated		
					CT3000	TT7005	TT7015	TT8115	TT8125	TT8135	TT9215	TT9225	TT9235	TT5100	TT5080	TT9080	
	TNMG2.531	TNMG130404	.004-.018	.020-.157		•	•										
	TNMG2.532	TNMG130408	.004-.020	.020-.157		•	•										
	TNMG2.533	TNMG130412	.004-.022	.020-.157		•	•										
	TNMG2.531EA	TNMG130404EA	.002-.012	.005-.059							•	•	•		•	•	
	TNMG2.532EA	TNMG130408EA	.003-.016	.006-.059							•	•	•		•	•	
	TNMG2.531EM	TNMG130404EM	.005-.016	.020-.157							•	•	•		•	•	
	TNMG2.532EM	TNMG130408EM	.006-.016	.028-.157							•	•	•		•	•	
	TNMG2.531FG	TNMG130404FG	.003-.012	.010-.059				•	•						•		
	TNMG2.532FG	TNMG130408FG	.004-.014	.012-.059				•	•						•		
	TNMG2.533FG	TNMG130412FG	.006-.016	.014-.059				•	•						•		
	TNMG2.531FM	TNMG130404FM	.003-.012	.010-.059	•			•	•	•					•		
	TNMG2.532FM	TNMG130408FM	.004-.014	.012-.059	•			•	•	•					•		
	TNMG2.533FM	TNMG130412FM	.006-.016	.014-.059	•			•	•	•					•		
	TNMG2.531FT	TNMG130404FT	.003-.012	.010-.098				•	•	•					•		
	TNMG2.532FT	TNMG130408FT	.004-.016	.012-.098				•	•	•					•		
	TNMG2.533FT	TNMG130412FT	.006-.020	.014-.098				•	•	•					•		
	TNMG2.531MM	TNMG130404MM	.006-.018	.016-.138				•	•	•	•	•	•	•	•		
	TNMG2.532MM	TNMG130408MM	.008-.020	.020-.138				•	•	•	•	•	•	•	•		
	TNMG2.533MM	TNMG130412MM	.009-.020	.028-.138				•	•	•	•	•	•	•	•		
	TNMG2.531MT	TNMG130404MT	.004-.014	.031-.138				•	•	•					•		
	TNMG2.532MT	TNMG130408MT	.006-.018	.039X				•	•	•					•		
	TNMG2.533MT	TNMG130412MT	.008-.022	.047-.138				•	•	•					•		
	TNMG2.531PC	TNMG130404PC	.004-.012	.016-.118				•	•	•					•		
	TNMG2.532PC	TNMG130408PC	.006-.016	.020-.118				•	•	•					•		
	TNMG2.533PC	TNMG130412PC	.007-.020	.024-.118				•	•	•					•		
	TNGG2.531R/L	TNMG130404R/L	.005-.012	.039-.118	•												
	TNGG2.532R/L	TNMG130408R/L	.006-.014	.051-.118	•												

HCLNR/L HCBNR/L

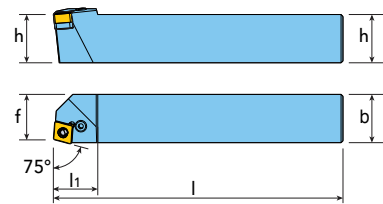
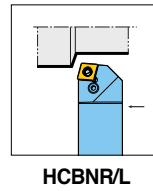
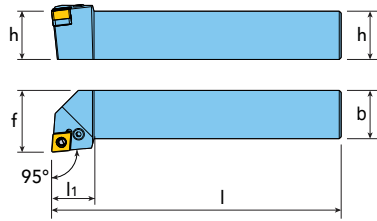
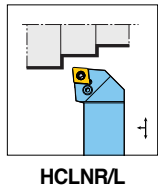

Designation	Dimensions (inch)					Insert	Components				
	h	b	l	l1	f		Lever	Screw	Seat	Seat Pin	Wrench
HCLNR/L 10-33A	0.625	0.625	4.00	0.87	0.750	CNMG33_	LCL09-NX	LCS3	LSC32A	LSP3A	L-W2.5
HCLNR/L 12-33B	0.750	0.750	4.50	0.87	1.000						
HCLNR/L 16-33D	1.000	1.000	6.00	0.87	1.250						
HCBNR/L 12-33B	0.750	0.750	4.50	0.91	0.691	CNMG33_	LCL09-NX	LCS3	LSC32A	LSP3A	L-W2.5
HCBNR/L 16-33D	1.000	1.000	6.00	0.91	0.941						

HDJNR/L HDNNR/L HDQNR/L

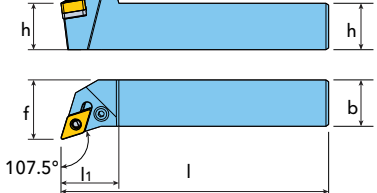
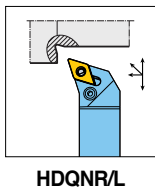
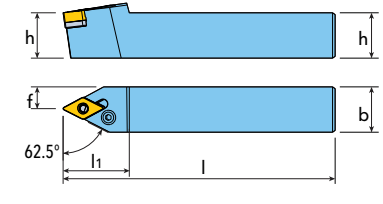
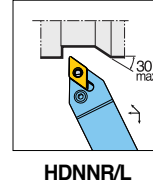
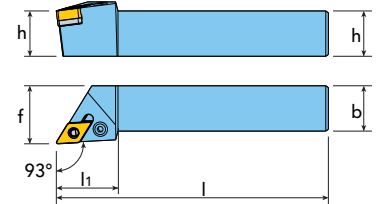
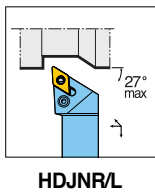

Designation	Dimensions (inch)					Insert	Components				
	h	b	l	l1	f		Lever	Screw	Seat	Seat Pin	Wrench
HDJNR/L 12-3.53.5B	0.750	0.750	4.50	1.34	1.000	DNMG3.53.5_	LCL11-NX	LCS4	LSD3.52	LSP4	L-W3
HDJNR/L 16-3.53.5D	1.000	1.000	6.00	1.34	1.250						
HDNNR/L 12-3.53.5B	0.750	0.750	4.50	1.44	0.375	DNMG3.53.5_	LCL11-NX	LCS4	LSD3.52	LSP4	L-W3
HDNNR/L 16-3.53.5D	1.000	1.000	6.00	1.44	0.500						
HDQNR/L 12-3.53.5B	0.750	0.750	4.50	1.22	1.000	DNMG3.53.5_	LCL11-NX	LCS4	LSD3.52	LSP4	L-W3
HDQNR/L 16-3.53.5D	1.000	1.000	6.00	1.22	1.250						

HSBNR/L HSDNN HSKNR/L HSSNR/L

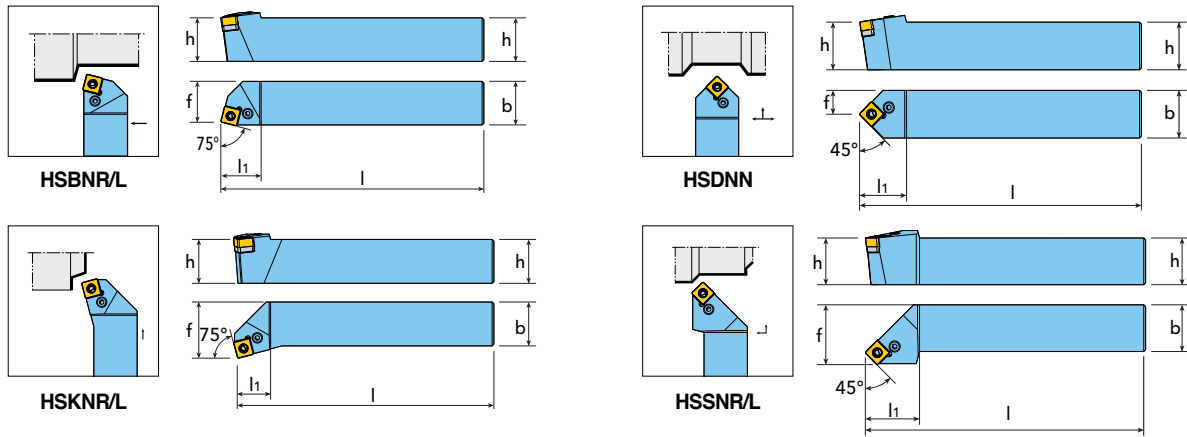

Designation	Dimensions (inch)					Insert	Components				
	h	b	l	l1	f		Lever	Screw	Seat	Seat Pin	Wrench
HSBNR/L 12-33B	0.750	0.750	4.50	0.91	0.691	SNMG33_	LCL09-NX	LCS3	LSS32A	LSP3A	L-W2.5
HSBNR/L 16-33D	1.000	1.000	6.00	0.91	0.941						
HSDNN 12-33B	0.750	0.750	4.50	0.98	0.375	SNMG33_	LCL09-NX	LCS3	LSS32A	LSP3A	L-W2.5
HSDNN 16-33D	1.000	1.000	6.00	0.98	0.500						
HSKNR/L 12-33B	0.750	0.750	4.50	0.75	1.000	SNMG33_	LCL09-NX	LCS3	LSS32A	LSP3A	L-W2.5
HSKNR/L 16-33D	1.000	1.000	6.00	0.75	1.250						
HSSNR/L 12-33B	0.750	0.750	4.50	0.85	1.000	SNMG33_	LCL09-NX	LCS3	LSS32A	LSP3A	L-W2.5
HSSNR/L 16-33D	1.000	1.000	6.00	1.14	1.250						

HTFNR/L HTGNR/L

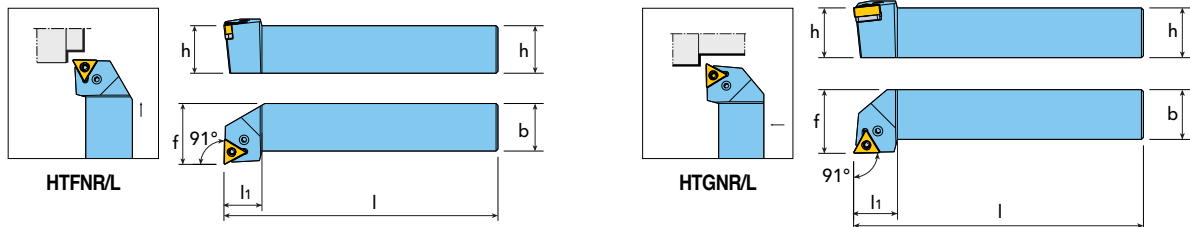

Designation	Dimensions (inch)					Insert	Components				
	h	b	l	l1	f		Lever	Screw	Seat	Seat Pin	Wrench
HTFNR/L 12-2.53B	0.750	0.750	4.50	0.79	1.000	TNMG2.53_	LCL08-NX	LCS3-NX	LST2.51.8	LSP3B	L-W2.5
HTFNR/L 16-2.53D	1.000	1.000	6.00	0.79	1.250						
HTGNR/L 10-2.53A	0.625	0.625	4.00	0.87	0.750	TNMG2.53_	LCL08-NX	LCS3-NX	LST2.51.8	LSP3B	L-W2.5
HTGNR/L 12-2.53B	0.750	0.750	4.50	0.87	1.000						
HTGNR/L 16-2.53D	1.000	1.000	6.00	0.87	1.250						

A-HCLNR/L

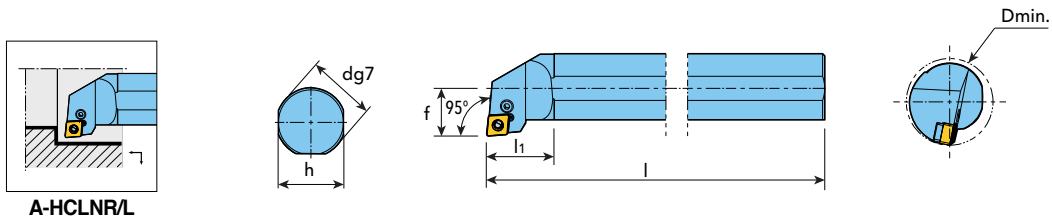

A-HCLNR/L

Designation	Dimensions (inch)						Insert	Components					
	d	h	l	l1	f	Dmin		Lever	Screw	Seat	Seat Pin	Snap Ring	Wrench
A10R-HCLNR/L-33	0.625	0.583	8.00	0.98	0.406	0.750	CNMG 33_	LCL09B-NX	LCS3B	-	-	LSR3B	L-W2
A12S-HCLNR/L-33	0.750	0.669	10.00	1.10	0.500	1.000							
A16T-HCLNR/L-33	1.000	0.921	12.00	1.22	0.640	1.250							
A20U-HCLNR/L-33	1.250	1.169	14.00	1.22	0.765	1.500							

A-HDUNR/L A-HDZNR/L

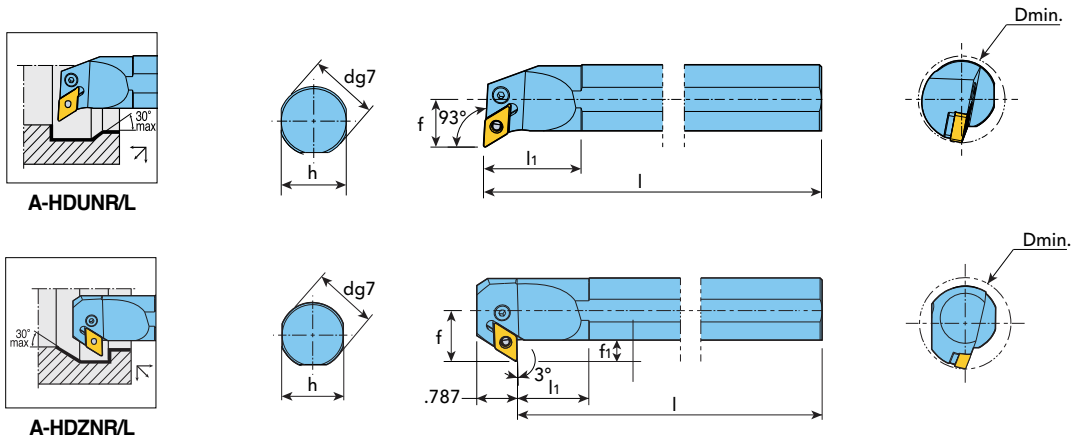

A-HDUNR/L

A-HDZNR/L

Designation	Dimensions (inch)							Insert	Components				
	d	h	l	l1	f	f1	Dmin		Lever	Screw	Seat	Seat Pin	Wrench
A20U-HDUNR/L-3.53.5	1.250	1.169	14.00	1.77	1.000	-	1.750	DNMG3.53.5_	LCL11-NX	LCS4S	LSD3.52B	LSP4	L-W3
A20U-HDZNR/L-3.53.5	1.250	1.169	14.00	1.36	1.000	0.434	1.750						

A-HSKNR/L

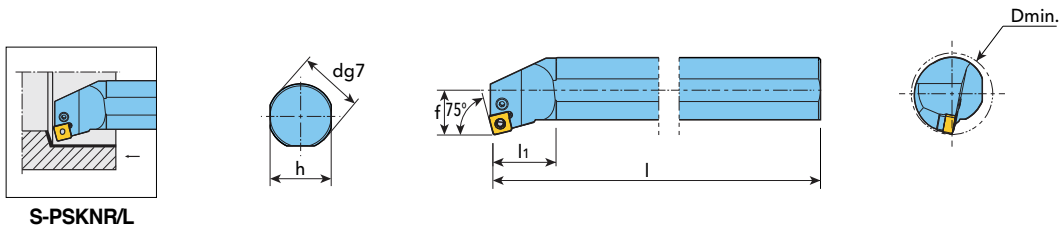

S-PSKNR/L

Designation	Dimensions (inch)						Insert	Components					
	d	h	l	l1	f	Dmin		Lever	Screw	Seat	Seat Pin	Snap Ring	Wrench
A16T-HSKNR/L-33	1.000	0.921	12.00	1.22	0.640	1.250	SNMG33_	LCL09B-NX	LCS3B	-	-	LSR3B	L-W2
A20U-HSKNR/L-33	1.250	1.169	14.00	1.22	0.765	1.500		LCL09-NX	LCS3	LSS32	LSP3A	-	L-W2.5

A-HTFNR/L

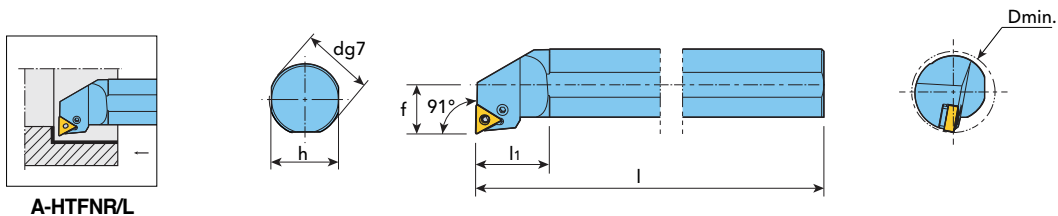

A-HTFNR/L

Designation	Dimensions (inch)						Insert	Components					
	d	h	l	l1	f	Dmin		Lever	Screw	Seat	Seat Pin	Snap Ring	Wrench
A10R-HTFNR/L-2.53	0.625	0.583	8.00	0.98	0.406	0.750	TNMG2.53_	LCL08B-NX	LCS3B	-	-	LSR3B	L-W2
A12S-HTFNR/L-2.53	0.750	0.669	10.00	1.10	0.500	1.000							
A16T-HTFNR/L-2.53	1.000	0.921	12.00	1.30	0.640	1.250		LCL08-NX	LCS3-NX	LST2.51.8B	LSP3B	-	L-W2.5
A20U-HTFNR/L-2.53	0.750	1.169	14.00	1.30	0.765	1.500							

HCLNR/L*

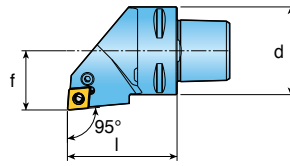
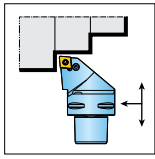

compatible with Sandvik's COROMANT CAPTO (**) system.

Designation	Dimension (mm)			Insert	Components					
	d	f	l		Lever	Screw	Shim	Shim Pin	Nozzle	Wrench
C4-HCLNR/L 27050-0904	40	27	50	CNMG 33 □	LCL 09-NX	LCS 3	LSC 32	LSP 3A	NZ 83	L-W 2.5

HDJNR/L*

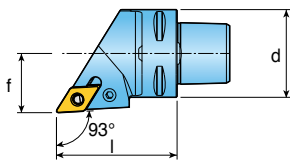
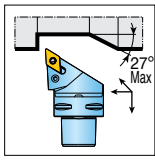

compatible with Sandvik's COROMANT CAPTO (**) system.

Designation	Dimension (mm)			Insert	Components					
	d	f	l		Lever	Screw	Shim	Shim Pin	Nozzle	Wrench
C4-HDJNR/L 27055-1305	40	27	55	DNMG 3.53.5 □	LCL 11-NX	LCS 4	LSD 3.52	LSP 4	NZ 83	L-W 3

HSSNR/L*

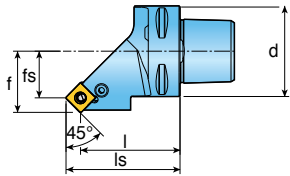
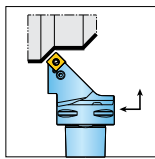

compatible with Sandvik's COROMANT CAPTO (**) system.

Designation	Dimension (mm)					Insert	Components					
	d	f	fs	l	ls		Lever	Screw	Shim	Shim Pin	Nozzle	Wrench
C4-HSSNR/L 27042-0904	40	27	20.6	44	50.3	SNMG 33 □	LCL 09-NX	LCS 3	LSS 32A	LSP 3A	NZ 83	L-W 2.5

HTGNR/L* HTJNR/L*

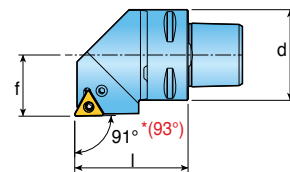
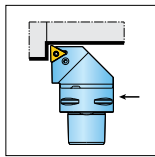

compatible with Sandvik's COROMANT CAPTO (**) system.

Designation	Dimension (mm)			Insert	Components					
	d	f	l		Lever	Screw	Shim	Shim Pin	Nozzle	Wrench
C4-HTGNR/L 27050-1304	40	27	50	TNMG 2.53 □	LCL 08-NX	LCS 3-NX	LST 2.51.8	LSP 3B	NZ 83	L-W 2.5
C4-HTJNR/L 27050-1304	40	27	50							

¹Marked : Entering angle of HTJNR/L is 93 degrees.

GOLD DUTY

HB CHIPBREAKER FOR SEMI HEAVY TURNING

- Low cutting forces and an optimized chipbreaker suitable for semi heavy machining
- Hook lever clamping system gives unique contact surface with large convex double sided insert
- Unique insert and shim profile offer maximum stability in semi-heavy machining
- 3 dimensional geometry that is exchangeable with the ISO standard holder

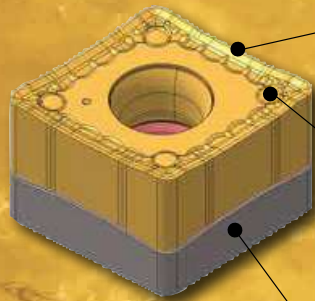

- Double-sided semi-heavy turning insert
 - ✓ Low cutting force
 - ✓ Optimized chipbreaker suitable for semi heavy machining

- Stable contact surface with four rest pads
 - ✓ Unique seat contact with large convex surface



- Exclusive seat
 - ✓ 3 dimensional geometry
 - ✓ Exchangeable with ISO Standard P-type holders

Contact Surface

CLAMPING FEATURES OF INSERT

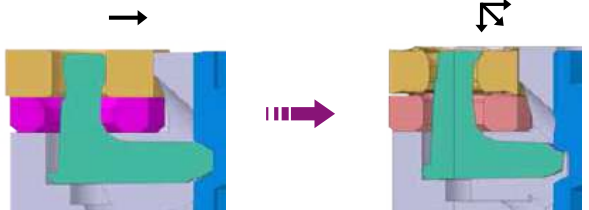

Conventional Lever Type
(P-Type Holders)

Hook Lever Type
(H-Type Holders)

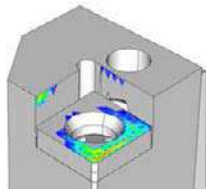

Poor clamping strength due to single directional force

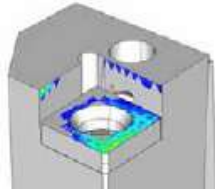

More stable clamping from multidirectional force

CHIP CONTROL RANGE

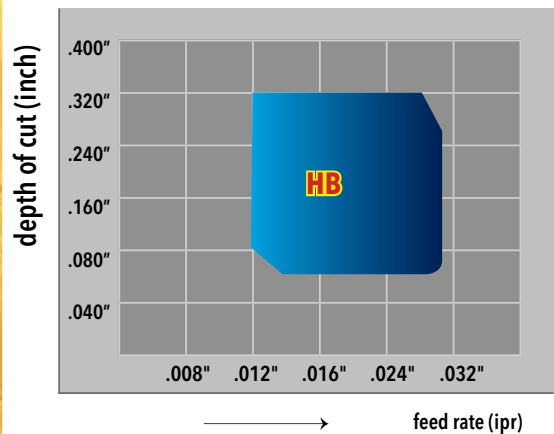

- Insert: CNMX 553 HB
- Cutting speed: 500 sfm
- Material: 0.45% Carbon Steel

GOLD DUTY CNMX HB

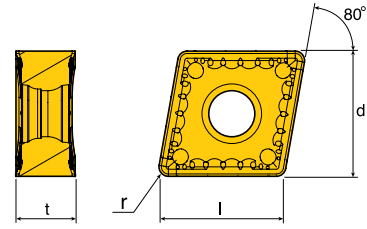

ANSI Description	ISO Description	feed (ipr)	ap (inch)	Dimensions (inch)				Grade	TT8115	TT8125	TT8135	TT5080	TT9080
				l	d	t	r						
CNMX 553 HB	CNMX 160712 HB	.012-.031	.060-.315	.583	.625	.272	.047		●	●	●	●	●
CNMX 554 HB	CNMX 160716 HB	.012-.031	.060-.315	.567	.625	.272	.063		●	●	●		

● = P ● = M ● = K ● = N ● = S ● = H

GOLD DUTY SNMX HB

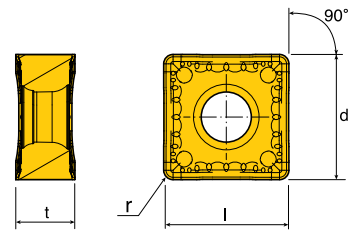

ANSI Description	ISO Description	feed (ipr)	ap (inch)	Dimensions (inch)				Grade	TT8115	TT8125
				l	d	t	r			
SNMX 553 HB	SNMX 150712 HB	.012-.031	.060-.315	.583	.625	.272	.047		●	●
SNMX 554 HB	SNMX 150716 HB	.012-.031	.060-.315	.567	.625	.272	.063		●	●

● = P ● = M ● = K ● = N ● = S ● = H

GOLD DUTY HCLNR/L

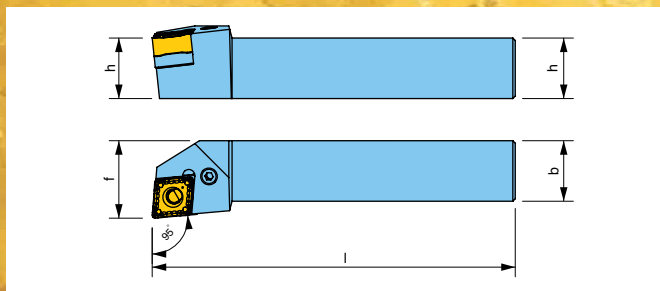

Designation	Dimensions (inch)			
	h	b	l	f
HCLNR/L 16-55D	1.00	1.00	6.0	1.25
HCLNR/L 20-55E	1.25	1.25	7.0	1.50
HCLNR/L 24-55E	1.50	1.50	7.0	2.00

HARDWARE							
	Insert	Lever	Screw	Shim	Shim Pin	Shim Pin Punch	Wrench
HCLNR/L 16-55D	CNMX 55 HB	LCL 16-NX	LCS 5-L25.5	LSC 54-NX	LSP 5	SPP 5-6	L-W 3
HCLNR/L 20-55E	CNMX 55 HB	LCL 16-NX	LCS 5-L25.5	LSC 54-NX	LSP 5	SPP 5-6	L-W 3
HCLNR/L 24-55E	CNMX 55 HB	LCL 16-NX	LCS 5-L25.5	LSC 54-NX	LSP 5	SPP 5-6	L-W 3

GOLD DUTY HCRNR/L

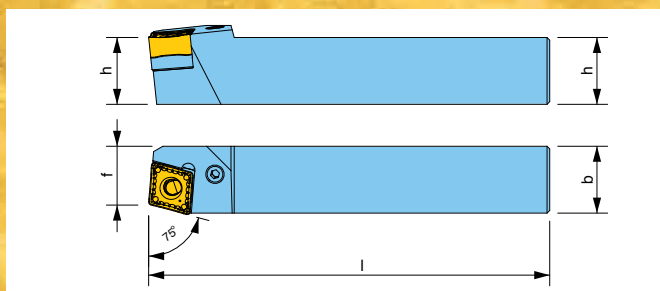





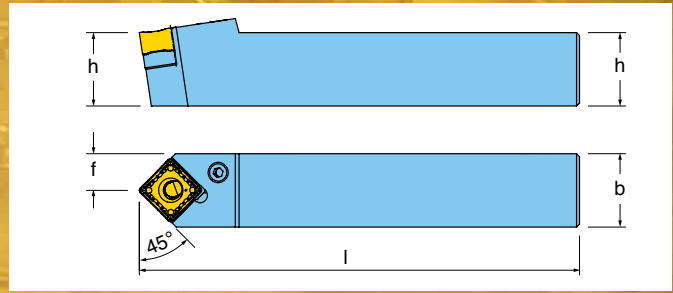

Designation	Dimensions (inch)			
	h	b	l	f
HCRNR/L 16-55D	1.00	1.00	6.0	1.047
HCRNR/L 20-55E	1.25	1.25	7.0	1.291
HCRNR/L 24-55E	1.50	1.50	7.0	1.697

HARDWARE							
	Insert	Lever	Screw	Shim	Shim Pin	Shim Pin Punch	Wrench
HCRNR/L 16-55D	CNMX 55 HB	LCL 16-NX	LCS 5-L25.5	LSC 54-NX	LSP 5	SPP 5-6	L-W 3
HCRNR/L 20-55E	CNMX 55 HB	LCL 16-NX	LCS 5-L25.5	LSC 54-NX	LSP 5	SPP 5-6	L-W 3
HCRNR/L 24-55E	CNMX 55 HB	LCL 16-NX	LCS 5-L25.5	LSC 54-NX	LSP 5	SPP 5-6	L-W 3

GOLD DUTY HSDNN







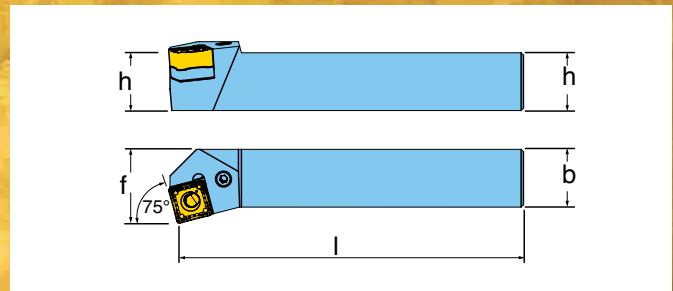

Designation	Dimensions (inch)			
	h	b	l	f
HSDNN 16-55D	1.00	1.00	6.0	.500
HSDNN 20-55E	1.25	1.25	7.0	.625
HSDNN 24-55D	1.50	1.50	7.0	.750

HARDWARE							
	Insert	Lever	Screw	Shim	Shim Pin	Shim Pin Punch	Wrench
HSDNN 16-55D	SNMX 55 □ HB	LCL 16-NX	LCS 5-L25.5	LSS 54-NX	LSP 5	SPP 5-6	L-W 3
HSDNN 20-55E	SNMX 55 □ HB	LCL 16-NX	LCS 5-L25.5	LSS 54-NX	LSP 5	SPP 5-6	L-W 3
HSDNN 24-55D	SNMX 55 □ HB	LCL 16-NX	LCS 5-L25.5	LSS 54-NX	LSP 5	SPP 5-6	L-W 3

GOLD DUTY HSKNR/L







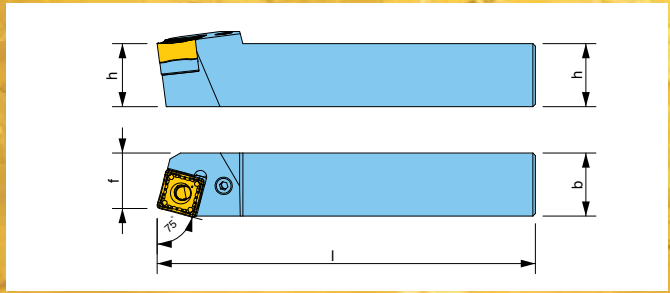

Designation	Dimensions (inch)			
	h	b	l	f
HSKNR/L 16-55D	1.00	1.00	6.0	1.25
HSKNR/L 20-55E	1.25	1.25	7.0	1.50
HSKNR/L 24-55D	1.50	1.50	7.0	2.00

HARDWARE							
	Insert	Lever	Screw	Shim	Shim Pin	Shim Pin Punch	Wrench
HSKNR/L 16-55D	SNMX 55 □ HB	LCL 16-NX	LCS 5-L25.5	LSS 54-NX	LSP 5	SPP 5-6	L-W 3
HSKNR/L 20-55E	SNMX 55 □ HB	LCL 16-NX	LCS 5-L25.5	LSS 54-NX	LSP 5	SPP 5-6	L-W 3
HSKNR/L 24-55D	SNMX 55 □ HB	LCL 16-NX	LCS 5-L25.5	LSS 54-NX	LSP 5	SPP 5-6	L-W 3

GOLD DUTY HSRNR/L



Designation	Dimensions (inch)			
	h	b	l	f
HSRNR/L 16-55D	1.00	1.00	6.0	1.047
HSRNR/L 20-55E	1.25	1.25	7.0	1.291
HSRNR/L 24-55D	1.50	1.50	7.0	1.697

HARDWARE							
	Insert	Lever	Screw	Shim	Shim Pin	Shim Pin Punch	Wrench
HSRNR/L 16-55D	SNMX 55 □ HB	LCL 16-NX	LCS 5-L25.5	LSS 54-NX	LSP 5	SPP 5-6	L-W 3
HSRNR/L 20-55E	SNMX 55 □ HB	LCL 16-NX	LCS 5-L25.5	LSS 54-NX	LSP 5	SPP 5-6	L-W 3
HSRNR/L 24-55D	SNMX 55 □ HB	LCL 16-NX	LCS 5-L25.5	LSS 54-NX	LSP 5	SPP 5-6	L-W 3

REPLACEMENT SEATS FOR ISO LEVER LOCKING HOLDERS (P-TYPE HOLDERS)

Ingersoll offers several replacement seats that are exchangeable with ISO Lever Lock Holders. However, for best performance, Ingersoll recommends that the HB insert be used with its exclusive H-type holder to maximize tool life.

Description	Shape	Seat for H-type Holder	Seat for ISO Lever Lock (P-type) Holder
CNMX 55_		LSC 54-NX	LSC 53-NX LSC 53-NXS
SNMX 55_		LSS 54-NX	LSS 53-NX LSS 53-NXS

LSC 53-NX: Same IC as Insert IC
LSC 53-NXS: Slightly smaller size than Insert IC



TO FORCE

40 MM HELIX CUTTING EDGE FOR LARGE PART MACHINING IN THE WIND POWER, SHIPBUILDING AND POWER PLANT INDUSTRIES

- High helix cutting edge
- Double lever clamping for maximum stability
- Unique geometry provides low cutting force
- 40mm cutting edge allows cutting depths up to 1.25"
- Suitable for medium-powered machines
- Facing and external turning possible
- Available in left hand and right hand
- 80 degree corner angle allows it to be used in the same manner as CNMG/CNMM Inserts
- 95 degree entrance angle allows facing and external machining

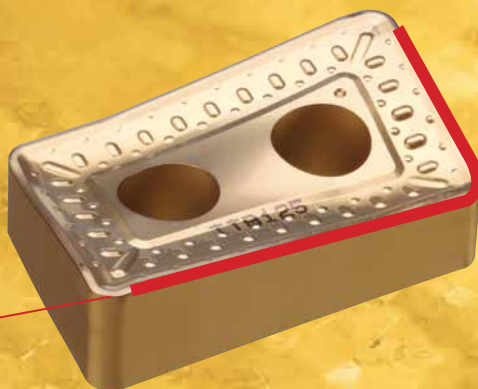

146

FINE GOLD 2013/2014

LNMM HX

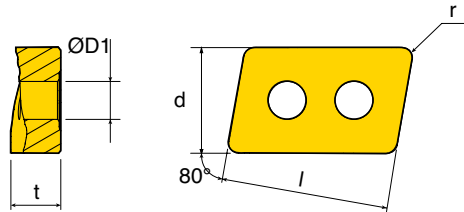
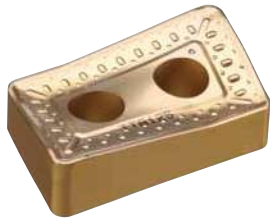

ANSI Number	ISO Number	feed (ipr)	DOC (inch)	Dimensions (inch)					Grade	TT8115	TT8125	TT7100
				d	l	t	r	D1				
LNMM 401224R/L-HX	LNMM 401224R/L-HX	.028-.059	.236-1.260	1.00	1.574	.472	.094	.360	●	●	●	

● = P ● = M ● = K ● = N ● = S ○ = H

2PLLNR/L

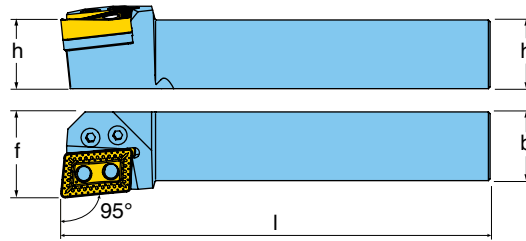

Designation	h	Dimension (inch)			Insert	Lever	Screw	Shim	Shim Pin	Wrench
		b	l	f						
2PLLNR/L L24-4012-10	1.50	1.50	10.0	2.00	LNMM 401224R/L-HX	LCL 8	LCS 8-L39	LN 4025-T6.35 R/L	LSP 8	L-W 5
2PLLNR/L L32-4012-12	2.00	2.00	12.0	2.35	LNMM 401224R/L-HX	LCL 8	LCS 8-L39	LN 4025-T6.35 R/L	LSP 8	L-W 5

TO FORCE

50 MM CUTTING EDGE

FOR LARGE PART MACHINING IN THE WIND POWER, SHIPBUILDING AND POWER PLANT INDUSTRIES

- 50mm (1.97") cutting edge enables cutting up to 45mm (1.77") depth of cut
- Rectilinear shaped cutting edge ideal for heavy roughing on high-powered machines
- HD insert suitable for continuous machining
- HY insert suitable for interrupted cutting
- Two blind holes and two-lever clamping system provide simple but strong clamping forces

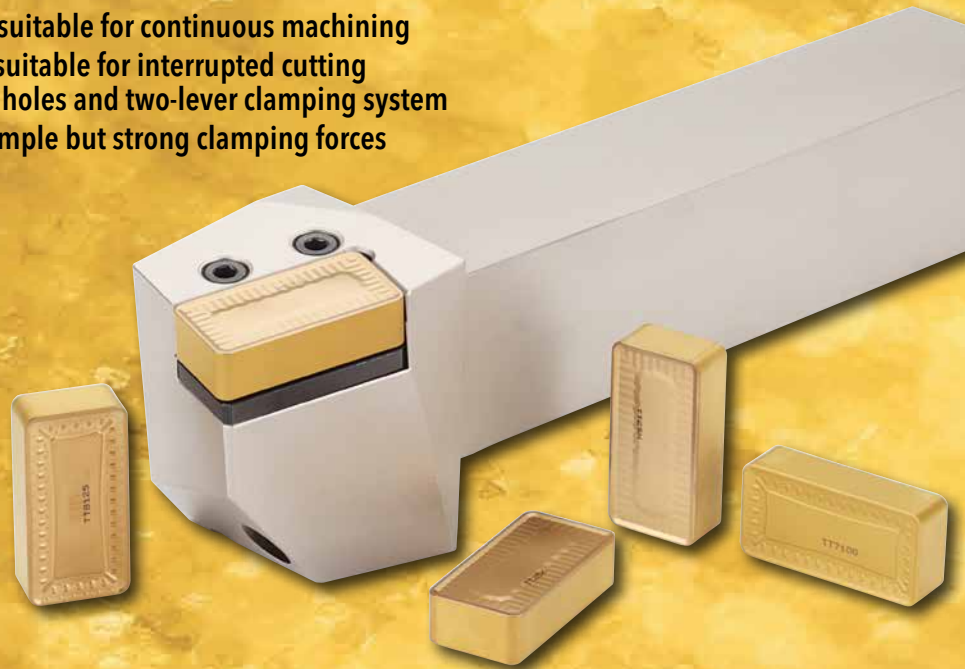

2PLBNR/L

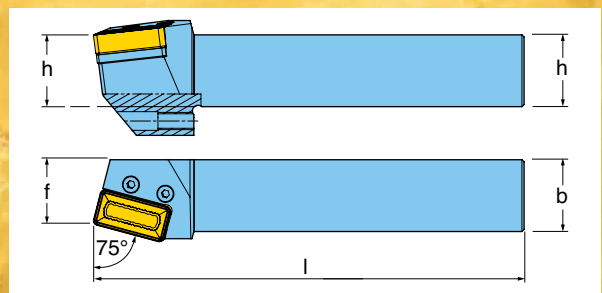

DESIGNATION	Dimensions (inch)				Insert	Lever	Screw	Shim	Shim Pin	Set Screw	Wrench
	h	b	l	f							
2PLBNR/L 32-T5014	2.00	2.00	12.00	1.77	LMX	LCL 8	LCS 8-L43	LN 5025-T6.35	LSP 8	SS M12X1.75X25	L-W 5

■ LNMX HD

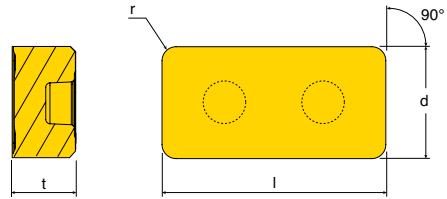

ANSI Number	ISO Number	feed (ipr)	DOC (inch)	Dimensions (inch)				Grade	TT8115	TT8125	TT7100
				d	l	t	r				
LNMX 501432HD	LNMX 501432 HD	.028-.063	.236-1.57	1.00	2.00	.559	.126		●	●	●

● = P ● = M ● = K ● = N ● = S ○ = H

■ LNMX HY

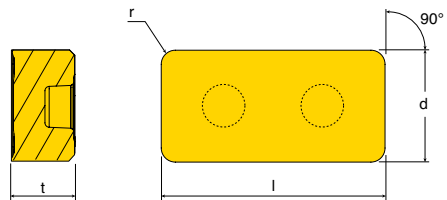

ANSI Number	ISO Number	feed (ipr)	DOC (inch)	Dimensions (inch)				Grade	TT8125	TT7100	TT9225
				d	l	t	r				
LNMX 501432HY	LNMX 501432 HY	.025-.059	.197-1.57	1.00	2.00	.559	.126		●	●	●

NEW!

● = P ● = M ● = K ● = N ● = S ○ = H



DOUBLE SIDED INSERT WITH 1.25" CUTTING EDGE

- The front side has a negative HD or HT chip breaker suitable for heavy machining.
- The back side has a lighter chip breaker designed to minimize the cutting load and break chips effectively when machining depths of cut less than .200".
- Strong clamping force due to hook lever system.

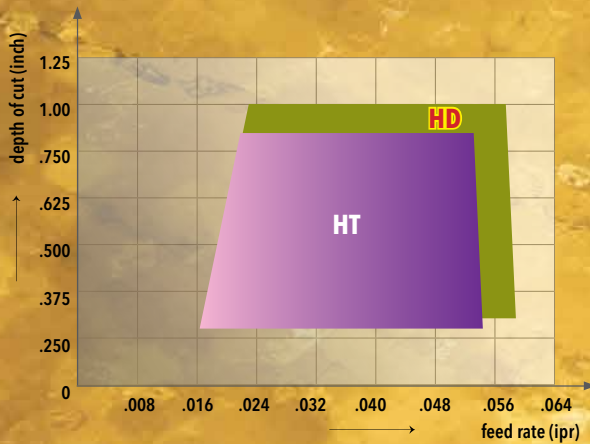

SNMD HD/HT INSERTS



For Heavy



For Finishing

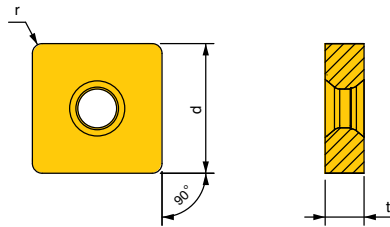

- P** Carbon Steel C: 0.45%
- M** Austenitic Stainless Steel
- K** High Tensile Cast Iron
- N** Aluminum
- S** Inconel
- H** Hardened Steel

ANSI DESIGNATION	ISO DESIGNATION	D1	d	Dimensions (inches)			feed (ipr)	ap	Grade	TT8115	TT8125	TT7100
				t	r							
SNMD 1066 HD	SNMD 310924 HD	.375	1.250	.375	.094		.023-.060	.276-1.000	•	•	•	
SNMD 1066 HT	SNMD 310924 HT	.375	1.250	.375	.094		.020-.056	.240-.875	•	•	•	

HSBNR/L

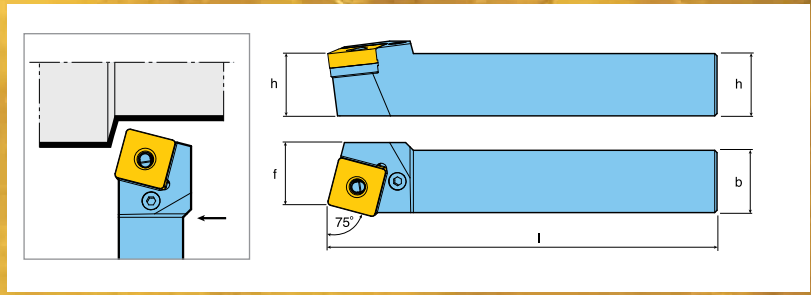
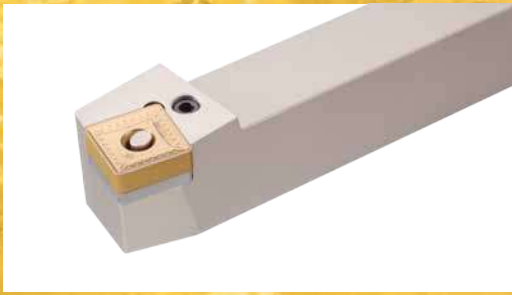

DESIGNATION	R	L	Dimensions (mm)				Insert	Lever	Screw	Shim	Shim Pin	Wrench
			h	b	l	f						
HSBNR/L 4040 S3109	•	•	40	40	250	35	SNM □ 1066 □ □	LCL 32-NX	LCS 8	LSS 104	LSP 8	L-W 5
HSBNR/L 5050 T3109	•	•	50	50	300	43						

• Marked: Standard items
INCH HOLDERS CAN BE PRODUCED AS SPECIALS.

HSDNN

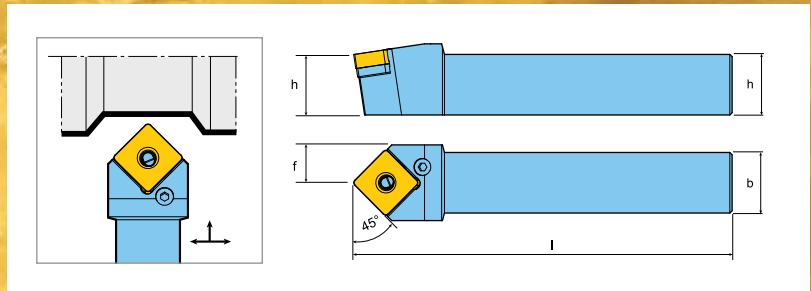

DESIGNATION	R	L	Dimensions (mm)				Insert	Lever	Screw	Shim	Shim Pin	Wrench
			h	b	l	f						
HSDNN 4040 S3109	•	•	40	40	250	35	SNM □ 1066 □ □	LCL 32-NX	LCS 8	LSS 104	LSP 8	L-W 5
HSDNN 5050 T3109	•	•	50	50	300	43						

• Marked: Standard items
INCH HOLDERS CAN BE PRODUCED AS SPECIALS.

ToFORCE

DOUBLE SIDED H SERIES CHIPBREAKERS NEW DOUBLE-SIDED CHIPBREAKER INSERTS FOR ROUGH AND FINISH MACHINING

Most cutting tool manufacturers design and produce single-sided ISO turning inserts in order to provide high levels of strength and toughness in heavy turning applications. Ingersoll has developed a new concept that utilizes the otherwise useless underside of these single-sided inserts for finish turning capacity. The result is the **ToFORCE** product line that combines a heavy roughing insert with a finishing insert.

The new concept of double-sided inserts utilizes our most aggressive chip breaker geometry types such as the HT, HY, and HZ for 80 degree CNMD and 90 degree SNMD inserts for heavy rough machining. Also new is the HD roughing chip breaker, which is designed to protect the insert with a smooth chip-breaking action when machining deeply stepped parts such as shafts. The underside of all these inserts contains a common style, finishing chip breaker that allows each insert to be used in the same holder, under different operating conditions, for final finishing passes on large work pieces.

This new product summarizes the Ingersoll spirit that never stops developing innovative new products to improve cost reduction solutions to its customers.

CNMD

HT



HD

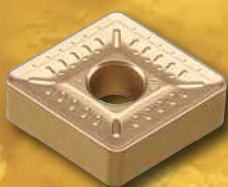

HY

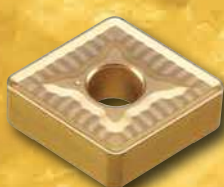

HZ



ToFORCE

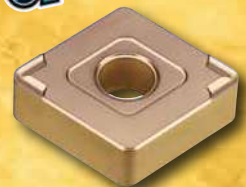

BONUS!

SNMD

HT

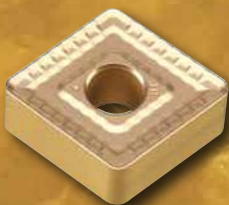

HD



HY



HZ



ToFORCE



BONUS!

FEATURES

- Utilizes both sides of the insert to improve economy & cost reduction
- Available in a variety of sizes and chip breakers to meet customers specific heavy rough machining requirements
- Economy is further improved by using one tool holder for rough and finish machining

TYPICAL CNMM/SNMM STYLE

SINGLE-SIDED



upper-side

Rough machining

under-side

Not utilized

DOUBLE-SIDED!

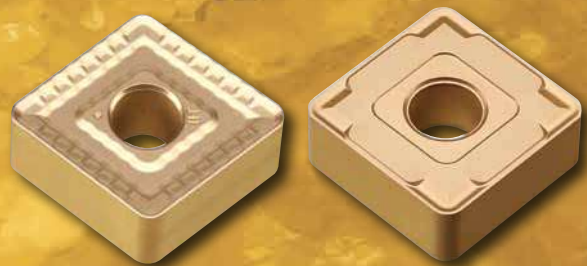

upper-side

Rough machining

under-side

Finish machining

The upper-side of the double sided insert can be used in the same manner as a single-sided insert.
The under-side can then be used when finish machining is required.

GUIDELINE FOR INSERT USE



under-side

storage

upper-side

1. Commence operation on finish machining first using the under-side of insert
2. Operate rough machining with the upper-side after edges on under-side are used

UNDER-SIDE FINISH MACHINING PARAMETERS

Depth of Cut (inches)	Feed Rate (ipr)
.120" - .200"	.024" - (.016"-.032")

- Insert : CNMD 866 HD
- Cutting speed: 100 m/min
- Material: 0.45% Carbon Steel

CHIP BREAKING RANGE

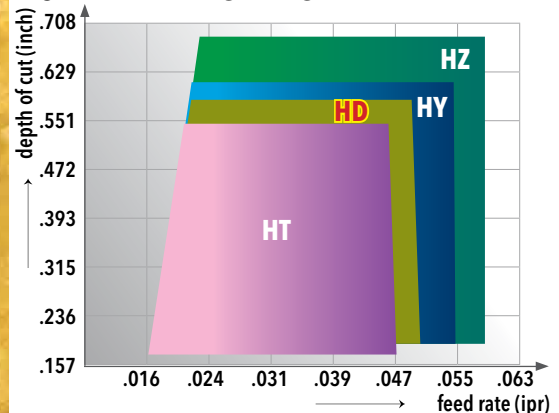

CNMD HD

Roughing



Finishing

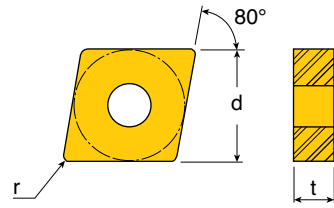

ANSI Number	ISO Number	feed* (ipr)	DOC* (inch)	Dimensions (inch)			Grade	TT8115	TT8125
				d	t	r			
CNMD 866 HD		.022-.059	.160-.590	1.00	.375	.094		●	●

* See introduction page for finish side parameters

● = P ● = M ● = K ● = N ● = S ○ = H

CNMD HT

Roughing

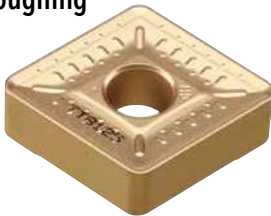

Finishing

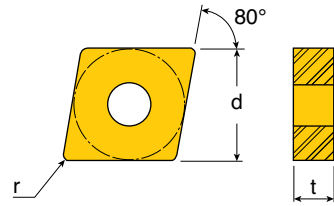

ANSI Number	ISO Number	feed* (ipr)	DOC* (inch)	Dimensions (inch)			Grade	TT8115	TT8125
				d	t	r			
CNMD 646 HT	CNMD 190624 HT	.014-.035	.160-.355	.750	.250	.094		●	●
CNMD 866 HT	CNMD 250924 HT	.022-.051	.200-.470	1.00	.375	.094		●	●

* See introduction page for finish side parameters

● = P ● = M ● = K ● = N ● = S ○ = H

CNMD HY

Roughing

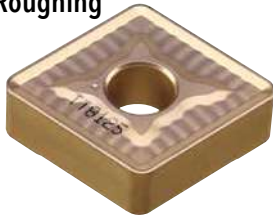

Finishing

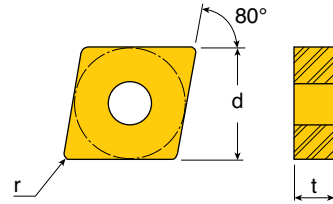

ANSI Number	ISO Number	feed* (ipr)	DOC* (inch)	Dimensions (inch)			Grade	TT8115	TT8125
				d	t	r			
CNMD 646 HY	CNMD 190624 HY	.020-.043	.160-.470	.750	.250	.094	●	●	
CNMD 866 HY	CNMD 250924 HY	.022-.059	.160-.590	1.00	.375	.094	●	●	

* See introduction page for finish side parameters

● = P ● = M ● = K ● = N ● = S ○ = H

CNMD HZ

Roughing



Finishing

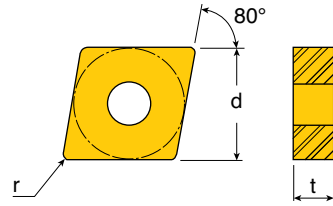

ANSI Number	ISO Number	feed* (ipr)	DOC* (inch)	Dimensions (inch)			Grade	TT8115	TT8125
				d	t	r			
CNMD 866 HZ	CNMD 250924 HZ	.022-.059	.160-.590	1.00	.375	.094	●	●	

* See introduction page for finish side parameters

● = P ● = M ● = K ● = N ● = S ○ = H

SNMD HD

Roughing



Finishing

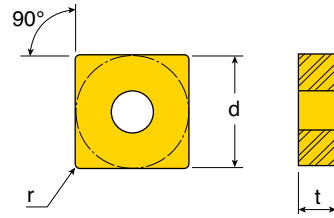

ANSI Number	ISO Number	feed* (ipr)	DOC* (inch)	Dimensions (inch)			Grade	TT8115	TT8125
				d	t	r			
SNMD 866 HD	SNMD 250924 HD	.022-.059	.160-.590	1.00	.375	.094	●	●	

* See introduction page for finish side parameters

● = P ● = M ● = K ● = N ● = S ○ = H

SNMD HT

Roughing

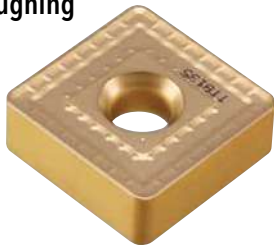

Finishing

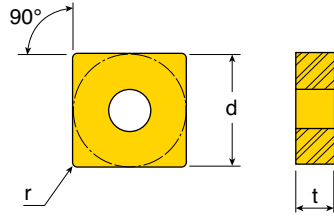

ANSI Number	ISO Number	feed* (ipr)	DOC* (inch)	Dimensions (inch)			Grade	TT8115	TT8125
				d	t	r			
SNMD 646 HT	SNMD 190624 HT	.022-.047	.160-.355	.750	.250	.094	●	●	
SNMD 866 HT	SNMD 250924 HT	.022-.051	.200-.470	1.00	.375	.094			

* See introduction page for finish side parameters

● = P ● = M ● = K ● = N ● = S ○ = H

■ SNMD HY

Roughing



Finishing

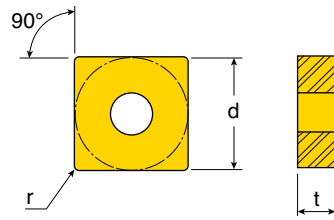

ANSI Number	ISO Number	feed* (ipr)	DOC* (inch)	Dimensions (inch)			Grade	TT8115	TT8125
				d	t	r			
SNMD 646 HY	SNMD 190624 HY	.020-.043	.160-.470	.750	.250	.094	●	●	
SNMD 866 HY	SNMD 250924 HY	.022-.059	.160-.590	1.00	.375	.094	●	●	

* See introduction page for finish side parameters

● = P ● = M ● = K ● = N ● = S ● = H

■ SNMD HZ

Roughing



Finishing

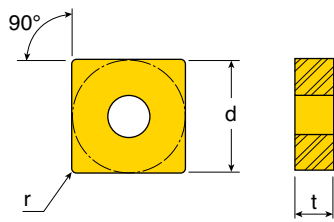

ANSI Number	ISO Number	feed* (ipr)	DOC* (inch)	Dimensions (inch)			Grade	TT8115	TT8125
				d	t	r			
SNMD 866 HZ	SNMD 250924 HZ	.022-.059	.160-.590	1.00	.375	.094	●	●	

* See introduction page for finish side parameters

● = P ● = M ● = K ● = N ● = S ● = H



EM CHIPBREAKER FOR STAINLESS STEEL MACHINING

Ingersoll previously introduced two new chipbreakers for machining stainless steels and exotic materials: The EA chipbreaker for finish to semi-finish operations in low depths of cut, and the ET chipbreaker for rough machining of these materials. The new EM chipbreaker is designed for medium applications where customers desire a single insert that encompasses many of the same features offered by the EA and ET.

The EM chipbreaker features a sharp land that reduces machining load during medium machining applications, while simultaneously reducing build up material on the cutting edge. The design also includes a broad boss face that dissipates heat on the upper side of the chipbreaker, improving the surface contact ratio while maximizing tool life. The result is an insert that provides stable performance in difficult to machine materials over a wide range of feed rates and cutting depths.

EM FOR MEDIUM

EA FOR FINISHING

ET FOR ROUGHING

CNMG EM



ANSI Number	ISO Number	feed (ipr)	DOC (inch)	Grade	TT9215	TT9225	TT9235	TT5080	TT9080
NEW! CNMG 431 EM	CNMG 120404 EM	.004-.018	.020-.200		●	●	●	●	●
CNMG 432 EM	CNMG 120408 EM	.005-.020	.020-.200		●	●	●	●	●
CNMG 433 EM	CNMG 120412 EM	.006-.022	.020-.200		●	●	●	●	●
CNMG 434 EM	CNMG 120416 EM	.007-.024	.020-.200		●	●	●	●	●
CNMG 542 EM	CNMG 160608 EM	.005-.020	.020-.250		●	●	●	●	●
CNMG 543 EM	CNMG 160612 EM	.006-.022	.020-.250		●	●	●	●	●
CNMG 544 EM	CNMG 160616 EM	.007-.024	.020-.250		●	●	●	●	●
CNMG 642 EM	CNMG 190608 EM	.005-.020	.020-.315		●	●	●	●	●
CNMG 643 EM	CNMG 190612 EM	.006-.022	.020-.315		●	●	●	●	●
CNMG 644 EM	CNMG 190616 EM	.007-.024	.020-.315		●	●	●	●	●

● = P ● = M ● = K ● = N ● = S ● = H

DNMG EM



ANSI Number	ISO Number	feed (ipr)	DOC (inch)	Grade	TT9215	TT9225	TT9235	TT5080	TT9080
DNMG 332 EM	DNMG 110408 EM*	.005-.020	.020-.160		●	●	●	●	●
DNMG 432 EM	DNMG 150408 EM	.005-.020	.020-.200		●	●	●	●	●
DNMG 442 EM	DNMG 150608 EM	.005-.020	.020-.200		●	●	●	●	●
DNMG 433 EM	DNMG 150412 EM	.006-.022	.020-.200		●	●	●	●	●
DNMG 443 EM	DNMG 150612 EM	.006-.022	.020-.200		●	●	●	●	●

*Insert is screw held

● = P ● = M ● = K ● = N ● = S ● = H

■ SNMG EM



ANSI Number	ISO Number	feed (ipr)	DOC (inch)	Grade				
				TT9215	TT9225	TT9235	TT5080	TT9080
SNMG 432 EM	SNMG 120408 EM	.005-.020	.031-.200	●	●	●	●	●
SNMG 433 EM	SNMG 120412 EM	.006-.022	.031-.200	●	●	●	●	●
SNMG 543 EM	SNMG 150612 EM	.006-.022	.031-.250	●	●	●	●	
SNMG 544 EM	SNMG 150616 EM	.007-.024	.031-.250	●	●	●	●	
SNMG 643 EM	SNMG 190612 EM	.006-.022	.031-.315	●	●	●	●	
SNMG 644 EM	SNMG 190616 EM	.007-.024	.031-.315	●	●	●	●	

● = P ● = M ● = K ● = N ● = S ○ = H

■ TNMG EM



ANSI Number	ISO Number	feed (ipr)	DOC (inch)	Grade				
				TT9215	TT9225	TT9235	TT5080	TT9080
TNMG 332 EM	TNMG 160408 EM	.005-.020	.031-.180	●	●	●	●	●
TNMG 333 EM	TNMG 160412 EM	.006-.022	.031-.180	●	●	●	●	●
TNMG 432 EM	TNMG 220408 EM	.005-.020	.031-.240	●	●	●	●	
TNMG 433 EM	TNMG 220412 EM	.006-.022	.031-.240	●	●	●	●	●

● = P ● = M ● = K ● = N ● = S ○ = H

VNMG EM



ANSI Number	ISO Number	feed (ipr)	DOC (inch)	Grade	TT9215	TT9225	TT9235	TT5080	TT9080
VNMG 332 EM	VNMG 160408 EM	.005-.020	.031-.140		●	●	●		●

● = P ● = M ● = K ● = N ● = S ○ = H

WNMG EM



ANSI Number	ISO Number	feed (ipr)	DOC (inch)	Grade	TT9215	TT9225	TT9235	TT5080	TT9080
WNMG 332 EM	WNMG 060408 EM	.005-.020	.031-.120		●	●	●	●	●
WNMG 333 EM	WNMG 060412 EM	.006-.022	.031-.120		●	●	●	●	●
WNMG 431 EM	WNMG 080404 EM	.004-.018	.031-.160		●	●	●	●	
WNMG 432 EM	WNMG 080408 EM	.005-.020	.031-.160		●	●	●	●	●
WNMG 433 EM	WNMG 080412 EM	.005-.022	.031-.160		●	●	●	●	●

● = P ● = M ● = K ● = N ● = S ○ = H

TOTURN™

PC CHIPBREAKER FOR POSITIVE INSERTS NEW SINGLE SIDED 'PC' CHIPBREAKER FOR SEMI-FINISH AND MEDIUM MACHINING

- Low cutting forces due to its positive rake angle
- Wide chip breaking range
- Suitable for a wide variety of materials
- For semi-finish to medium application
- 5°, 7°, and 11° positive inserts available

CHIP CONTROL RANGE

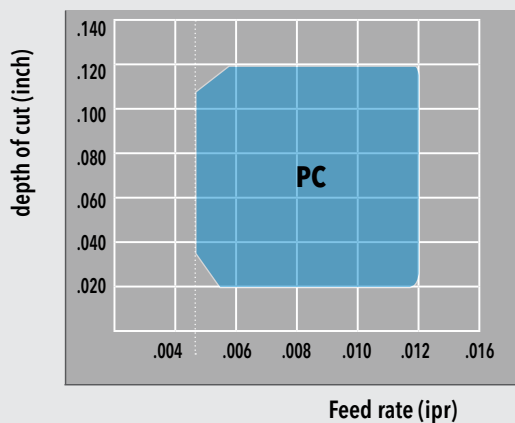

- Insert: CCMT 32.52 (09T308)
- Cutting speed: 650 sfm
- Material: 0.45% Carbon steel

POSITIVE PC INSERT GEOMETRY

- Slightly Waved cutting Edge
- Dimple Design Low cutting Force
- Wide Groove Smooth Cutting

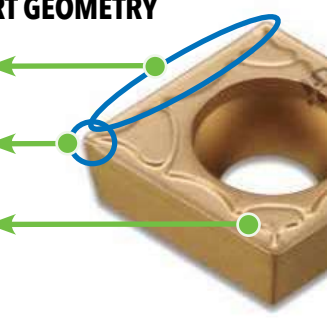

VBMT PC - 5° POSITIVE INSERTS WITH PC CHIPBREAKER



ANSI Number	ISO Number	feed (ipr)	DOC (inch)	Grade	CT3000	TT8115	TT8125	TT9225	TT9080
VBMT331PC	VBMT160404PC	0.003 - 0.009	0.020 - 0.110		●●●●●	●●●●●	●●●●●	●●●●●	●●●●●
VBMT332PC	VBMT160408PC	0.004 - 0.011	0.020 - 0.110		●●●●●	●●●●●	●●●●●	●●●●●	●●●●●
VBMT333PC	VBMT160412PC	0.004 - 0.011	0.020 - 0.110		●●●●●	●●●●●	●●●●●	●●●●●	●●●●●

● = P ● = M ● = K ● = N ● = S ○ = H

CCMT PC - 7° POSITIVE, 80° RHOMBIC INSERTS WITH PC CHIPBREAKER



ANSI Number	ISO Number	feed (ipr)	DOC (inch)	Grade	CT3000	T8115	T8125	TT9225	TT9080
CCMT21.51PC	CCMT060204PC	0.002 - 0.007	0.007 - 0.079		●●●	●●●	●●●	●●●	●●●
CCMT21.52PC	CCMT060208PC	0.003 - 0.010	0.010 - 0.079		●●●	●●●	●●●	●●●	●●●
CCMT32.51PC	CCMT09T304PC	0.003 - 0.010	0.010 - 0.118		●●●	●●●	●●●	●●●	●●●
CCMT32.52PC	CCMT09T308PC	0.004 - 0.011	0.011 - 0.118		●●●	●●●	●●●	●●●	●●●
CCMT431PC	CCMT120404PC	0.003 - 0.010	0.010 - 0.157		●●●	●●●	●●●	●●●	●●●
CCMT432PC	CCMT120408PC	0.004 - 0.012	0.012 - 0.157		●●●	●●●	●●●	●●●	●●●
CCMT433PC	CCMT120412PC	0.005 - 0.014	0.014 - 0.157		●●●	●●●	●●●	●●●	●●●

● = P ● = M ● = K ● = N ● = S ● = H

DCMT PC - 7° POSITIVE, 55° RHOMBIC INSERTS WITH PC CHIPBREAKER



ANSI Number	ISO Number	feed (ipr)	DOC (inch)	Grade	CT3000	T8115	T8125	TT9225	TT9080
DCMT21.51PC	DCMT070204PC	0.002 - 0.007	0.012 - 0.079		●●●	●●●	●●●	●●●	●●●
DCMT21.52PC	DCMT070208PC	0.003 - 0.010	0.016 - 0.079		●●●	●●●	●●●	●●●	●●●
DCMT32.51PC	DCMT11T304PC	0.003 - 0.010	0.014 - 0.118		●●●	●●●	●●●	●●●	●●●
DCMT32.52PC	DCMT11T308PC	0.004 - 0.011	0.020 - 0.118		●●●	●●●	●●●	●●●	●●●
DCMT32.53PC	DCMT11T312PC	0.005 - 0.013	0.020 - 0.118		●●●	●●●	●●●	●●●	●●●

● = P ● = M ● = K ● = N ● = S ● = H

RCMT PC - 7° POSITIVE ROUND INSERTS WITH PC CHIPBREAKER



ANSI Number	ISO Number	feed (ipr)	DOC (inch)	Grade	TT8115	TT8125	TT9225	TT9235	TT5080
RCMT120400PC	RCMT120400PC	0.008 - 0.024	0.051 - 0.177		●	●	●	●	●

● = P ● = M ● = K ● = N ● = S ○ = H

SCMT PC - 7° POSITIVE SQUARE INSERTS WITH PC CHIPBREAKER



ANSI Number	ISO Number	feed (ipr)	DOC (inch)	Grade	CT3000	TT8115	TT8125	TT9225	TT9080
SCMT32.51PC	SCMT09T304PC	0.003 - 0.010	0.014 - 0.118		●	●	●	●	●
SCMT32.52PC	SCMT09T308PC	0.004 - 0.011	0.020 - 0.118		●	●	●	●	●
SCMT431PC	SCMT120404PC	0.003 - 0.010	0.016 - 0.157		●	●	●	●	●
SCMT432PC	SCMT120408PC	0.004 - 0.012	0.028 - 0.157		●	●	●	●	●
SCMT433PC	SCMT120412PC	0.005 - 0.014	0.039 - 0.157		●	●	●	●	●

● = P ● = M ● = K ● = N ● = S ○ = H

TCMT PC - 7° POSITIVE TRIANGULAR INSERTS WITH PC CHIPBREAKER

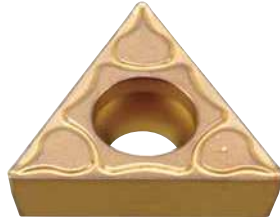

ANSI Number	ISO Number	feed (ipr)	DOC (inch)	Grade	CT3000	TT8115	TT8125	TT9215	TT9225	TT9080
TCMT731PC	TCMT090204PC	0.002 - 0.007	0.012 - 0.079		●●●	●	●		●	●
TCMT732PC	TCMT090208PC	0.003 - 0.010	0.016 - 0.079		●●●	●	●		●	●
TCMT21.51PC	TCMT110204PC	0.002 - 0.008	0.012 - 0.098		●●●	●	●	●	●	●
TCMT21.52PC	TCMT110208PC	0.004 - 0.010	0.017 - 0.098		●●●	●	●		●	●
TCMT32.51PC	TCMT16T304PC	0.003 - 0.010	0.014 - 0.118		●●●	●	●		●	●
TCMT32.52PC	TCMT16T308PC	0.004 - 0.011	0.020 - 0.118		●●●	●	●		●	●
TCMT32.53PC	TCMT16T312PC	0.005 - 0.014	0.024 - 0.118		●●●	●	●		●	●

● = P ● = M ● = K ● = N ● = S ● = H

VCMT PC - 7° POSITIVE 35° RHOMBIC INSERTS WITH PC CHIPBREAKER



VCMT 22x



VCMT 33x

ANSI Number	ISO Number	feed (ipr)	DOC (inch)	Grade	CT3000	TT8115	TT8125	TT9225	TT5100
VCMT221PC	VCMT110304PC	0.002 - 0.008	0.004 - 0.067		●●●	●	●	●	●
VCMT332PC	VCMT160408PC	0.002 - 0.008	0.012 - 0.079		●●●	●	●	●	

● = P ● = M ● = K ● = N ● = S ● = H

CPMT PC - 11° POSITIVE, 80° RHOMBIC INSERTS WITH PC CHIPBREAKER



ANSI Number	ISO Number	feed (ipr)	DOC (inch)	Grade	CT3000	TT7005	TT7015	TT8125	TT9225	TT5100	TT5080
CPMT21.51PC	CPMT060204PC	0.002 - 0.007	0.012 - 0.079		●	●	●		●	●	●
CPMT21.52PC	CPMT060208PC	0.003 - 0.010	0.016 - 0.079		●	●	●		●	●	●
CPMT32.51PC	CPMT09T304PC	0.003 - 0.010	0.018 - 0.118		●	●	●	●	●	●	●
CPMT32.52PC	CPMT09T308PC	0.004 - 0.012	0.024 - 0.118		●	●	●	●	●	●	●

● = P ● = M ● = K ● = N ● = S ○ = H

TPMT PC - 11° POSITIVE TRIANGULAR INSERTS WITH PC CHIPBREAKER



ANSI Number	ISO Number	feed (ipr)	DOC (inch)	Grade	CT3000	TT7005	TT7015	TT8115	TT8125	TT9225	TT9235	TT5080
TPMT731PC	TPMT090204PC	0.002 - 0.007	0.012 - 0.079		●					●		●
TPMT21.51PC	TPMT110204PC	0.002 - 0.008	0.016 - 0.098		●	●	●		●	●		
TPMT21.52PC	TPMT110208PC	0.004 - 0.010	0.020 - 0.098		●	●	●		●	●		
TPMT221PC	TPMT110304PC	0.002 - 0.008	0.016 - 0.098		●					●		●
TPMT222PC	TPMT110308PC	0.004 - 0.010	0.020 - 0.098		●				●	●		●
TPMT32.51PC	TPMT16T304PC	0.003 - 0.010	0.018 - 0.118					●	●	●	●	
TPMT32.52PC	TPMT16T308PC	0.004 - 0.012	0.020 - 0.118					●	●	●	●	

● = P ● = M ● = K ● = N ● = S ○ = H

TOTURN™

RA CHIPBREAKER FOR POSITIVE INSERTS FOR ROUGH MACHINING OF MEDIUM AND LARGE SIZED COMPONENTS

- Good chip control range at low feed rates and D.O.C
- Suitable for heavy & interrupted machining
- Wide chip control range



Chip Control Range

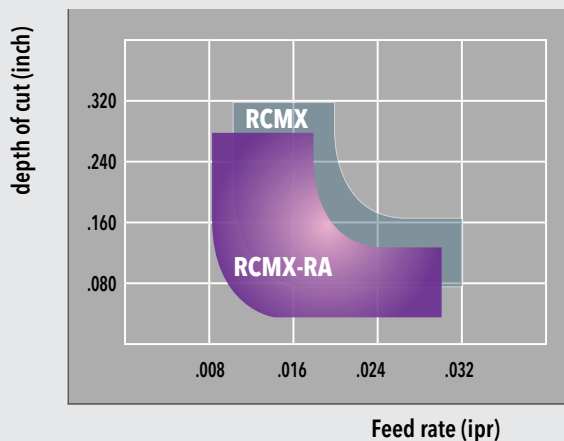

- Insert: RCMX 160600 RA
- Cutting speed: 325 sfm
- Material: 0.45% Carbon steel

RCMX RA

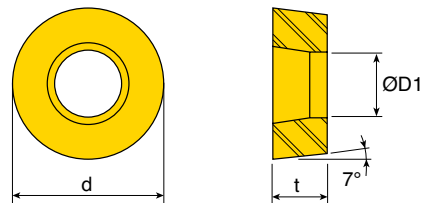

ANSI Number	ISO Number	feed (ipr)	DOC (inch)	Dimensions (inch)			Grade	TT8115	TT8125	TT8135
				d	t	D1				
RCMX100300RA	RCMX100300RA	0.008 - 0.020	0.039 - 0.157	0.394	0.125	0.142	●	●	●	
RCMX120400RA	RCMX120400RA	0.010 - 0.024	0.079 - 0.197	0.472	0.187	0.165	●	●	●	
RCMX160600RA	RCMX160600RA	0.014 - 0.030	0.098 - 0.276	0.630	0.250	0.205	●	●	●	
RCMX200600RA	RCMX200600RA	0.016 - 0.035	0.118 - 0.354	0.787	0.250	0.256	●	●	●	
RCMX250700RA	RCMX250700RA	0.020 - 0.047	0.138 - 0.472	0.984	0.312	0.283	●	●	●	
RCMX320900RA	RCMX320900RA	0.024 - 0.059	0.157 - 0.591	1.260	0.375	0.374	●	●	●	

● = P ● = M ● = K ● = N ● = S ● = H

TOTURN™

EXTERNAL HOLDERS FOR POSITIVE ROUND INSERTS (RCMX STYLE)

FOR TURNING AND PROFILING APPLICATIONS

- Neutral and handed holders.
- For 10mm to 32mm round inserts containing countersunk screw holes (RCMX type).
- Simple lever lock clamping for fast indexing.
- Lever contacts screw hole taper for increased stability.



PRDCN

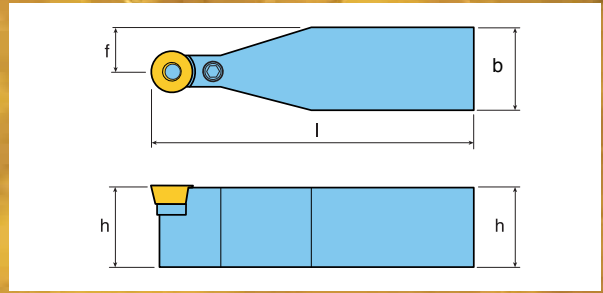

DESIGNATION	Dimensions (inch)					Insert	Lever	Screw	Shim	Shim Pin	Wrench
	h	b	l	l1	f						
PRDCN 12-10C	.75	.75	5.00	1.97	.375	RC□X 100300	LCL 10C	LCS 2	LSR 32	LSP 3A	L-W 2
PRDCN 16-10D	1.00	1.00	6.00	1.97	.500	RC□X 120400	LCL 12C	LCS 3	LSR 1203	LSP 3A	L-W 2.5
PRDCN 12-12C	.75	.75	5.00	1.97	.375	RC□X 120400	LCL 12C	LCS 3	LSR 1203	LSP 3A	L-W 2.5
PRDCN 16-12D	1.00	1.00	6.00	1.97	.500	RC□X 160600	LCL 16C	LCS 16C	LSR 1604	LSP 16C	L-W 2.5
PRDCN 20-12D	1.25	1.25	6.00	1.97	.625	RC□X 160600	LCL 16C	LCS 16C	LSR 1604	LSP 16C	L-W 2.5
PRDCN 16-16D	1.00	1.00	6.00	1.97	.500	RC□X 200600	LCL 20C	LCS 5	LSR 2004	LSP 5	L-W 3
PRDCN 20-16E	1.25	1.25	7.00	1.97	.625	RC□X 200600	LCL 20C	LCS 5	LSR 2004	LSP 5	L-W 3
PRDCN 20-20F	1.25	1.25	8.00	2.36	.625	RC□X 250700	LCL 25C	LCS 25C	LSR 2506	LSP 6	L-W 4
PRDCN 24-20X	1.50	1.50	10.00	2.76	.750	RC□X 250700	LCL 25C	LCS 25C	LSR 2506	LSP 6	L-W 4
PRDCN 24-25X	1.50	1.50	10.00	3.15	.750	RC□X 320900	LCL 32C	LCS 8	LSR 3206	LSP 8	L-W 5
PRDCN 32-32X	2.00	2.00	14.00	3.54	1.000	RC□X 320900	LCL 32C	LCS 8	LSR 3206	LSP 8	L-W 5

PRGCR/L

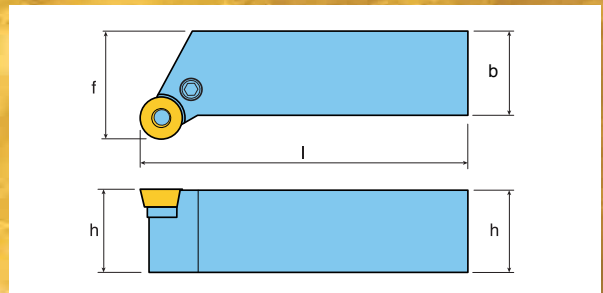

DESIGNATION	Dimensions (inch)					Insert	Lever	Screw	Shim	Shim Pin	Wrench
	h	b	l	l1	f						
PRGCR 12-10C	.75	.75	5.00	0.57	1.00	RC□X 100300	LCL 10C	LCS 2	LSR 32	LSP 3A	L-W 2
PRGCR/L 16-10D	1.00	1.00	6.00	.69	1.25	RC□X 120400	LCL 12C	LCS 3	LSR 1203	LSP 3A	L-W 2.5
PRGCR 12-12C	.75	.75	5.00	.71	1.00	RC□X 120400	LCL 12C	LCS 3	LSR 1203	LSP 3A	L-W 2.5
PRGCR/L 16-12D	1.00	1.00	6.00	.71	1.25	RC□X 160600	LCL 16C	LCS 16C	LSR 1604	LSP 16C	L-W 2.5
PRGCR/L 20-12D	1.25	1.25	6.00	.71	1.50	RC□X 160600	LCL 16C	LCS 16C	LSR 1604	LSP 16C	L-W 2.5
PRGCR 16-16D	1.00	1.00	6.00	.71	1.25	RC□X 200600	LCL 20C	LCS 5	LSR 2004	LSP 5	L-W 3
PRGCR/L 20-16E	1.25	1.25	7.00	.91	1.25	RC□X 200600	LCL 20C	LCS 5	LSR 2004	LSP 5	L-W 3
PRGCR/L 20-20F	1.25	1.25	8.00	1.08	1.50	RC□X 250700	LCL 25C	LCS 25C	LSR 2506	LSP 6	L-W 4
PRGCR 24-25X	1.50	1.50	10.00	1.32	2.00	RC□X 250700	LCL 25C	LCS 25C	LSR 2506	LSP 6	L-W 4

TOTURN™

RX CHIPBREAKER FOR ROUGH MACHINING OF LARGE PARTS

- Negative and positive cutting edge: improves stability and machinability
- Helical cutting edge: increases tool life by minimizing cutting resistance
- Applicable to a broad range of workpieces

- Insert : CNMM 644 RX
- Cutting speed(Vc): 325 sfm
- Material: 0.45% Carbon steel

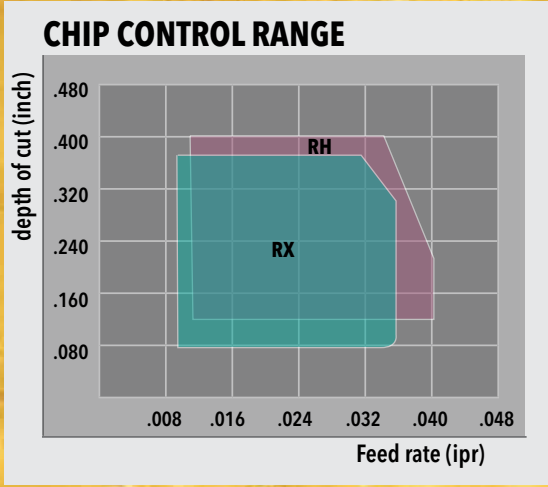

CNMM RX

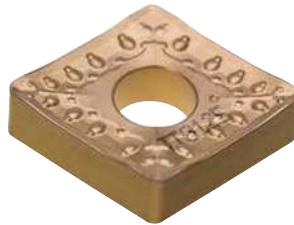

ANSI Number	ISO Number	feed (ipr)	DOC (inch)	Grade	T8115	T8125	T8135
CNMM432RX	CNMM120408RX	0.008 - 0.022	0.028 - 0.276		●	●	●
CNMM433RX	CNMM120412RX	0.010 - 0.028	0.039 - 0.276		●	●	●
CNMM543RX	CNMM160612RX	0.010 - 0.028	0.039 - 0.354		●	●	●
CNMM544RX	CNMM160616RX	0.012 - 0.035	0.059 - 0.354		●	●	●
CNMM546RX	CNMM160624RX	0.014 - 0.047	0.079 - 0.354		●	●	●
CNMM642RX	CNMM190608RX	0.008 - 0.022	0.028 - 0.394		●	●	●
CNMM643RX	CNMM190612RX	0.010 - 0.028	0.039 - 0.394		●	●	●
CNMM644RX	CNMM190616RX	0.012 - 0.035	0.059 - 0.394		●	●	●
CNMM646RX	CNMM190624RX	0.014 - 0.043	0.079 - 0.394		●	●	●
CNMM856RX	CNMM250724RX	0.014 - 0.047	0.079 - 0.472		●	●	●
CNMM866RX	CNMM250924RX	0.014 - 0.047	0.079 - 0.472		●	●	●

● = P ● = M ● = K ● = N ● = S ○ = H

TNMM RX



ANSI Number	ISO Number	feed (ipr)	DOC (inch)	Grade	TT8115	TT8125	TT8135
TNMM332RX	TNMM160408RX	0.008 - 0.022	0.028 - 0.236		●	●	●
TNMM333RX	TNMM160412RX	0.010 - 0.028	0.039 - 0.276		●	●	●
TNMM432RX	TNMM220408RX	0.008 - 0.022	0.028 - 0.295		●	●	●
TNMM433RX	TNMM220412RX	0.010 - 0.028	0.039 - 0.295		●	●	●
TNMM434RX	TNMM220416RX	0.012 - 0.035	0.059 - 0.295		●	●	●

● = P ● = M ● = K ● = N ● = S ○ = H

SNMM RX

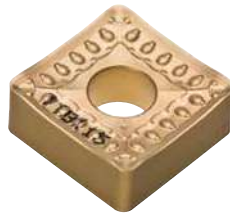

ANSI Number	ISO Number	feed (ipr)	DOC (inch)	Grade	TT8115	TT8125	TT8135
SNMM432RX	SNMM120408RX	0.008 - 0.022	0.028 - 0.276		●	●	●
SNMM433RX	SNMM120412RX	0.010 - 0.028	0.039 - 0.276		●	●	●
SNMM543RX	SNMM150612RX	0.010 - 0.028	0.039 - 0.354		●	●	●
SNMM643RX	SNMM190612RX	0.010 - 0.028	0.039 - 0.394		●	●	●
SNMM644RX	SNMM190616RX	0.012 - 0.035	0.059 - 0.394		●	●	●
SNMM646RX	SNMM190624RX	0.014 - 0.043	0.079 - 0.394		●	●	●
SNMM856RX	SNMM250724RX	0.014 - 0.047	0.079 - 0.472		●	●	●
SNMM866RX	SNMM250924RX	0.014 - 0.047	0.079 - 0.472		●	●	●

● = P ● = M ● = K ● = N ● = S ○ = H



SA CHIPBREAKER GROUND POSITIVE ISO INSERTS FOR HIGH PRECISION TURNING

- Peripherally ground geometry provides high accuracy
- Low cutting forces due to an inclined, sharp cutting edge and wide groove geometry
- Excellent chip control at low feed rates and depths of cut, due to an optimized chip-breaker design
- Grade TT9020 suitable for Swiss sliding head turning centers
- Grade TT5030 ideal for precision aerospace applications

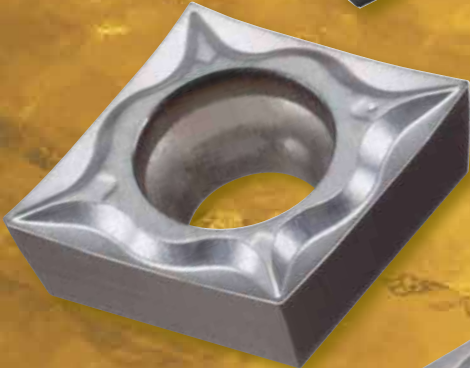
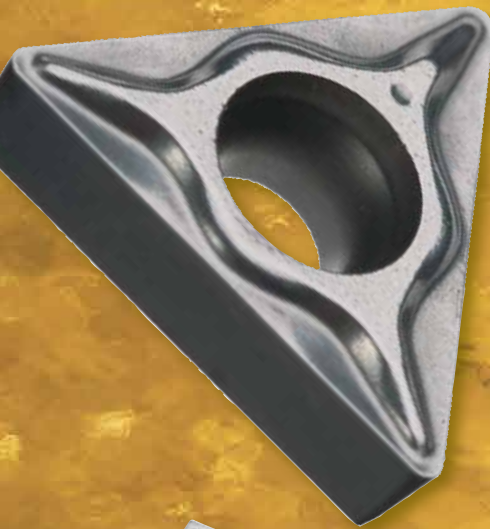

■ CCGT SA - 7° POSITIVE, 80° RHOMBIC GROUND INSERTS WITH SA CHIPBREAKER

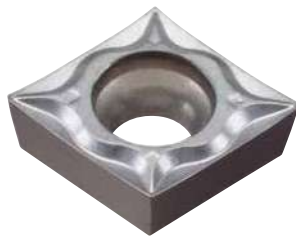

ANSI Number	ISO Number	feed (ipr)	DOC (inch)	Grade	
				TT5080	TT9020
CCGT 21.50 SA	CCGT 060201 SA	.0008 - .006	.004 - .060	●	●
CCGT 21.50.5 SA	CCGT 060202 SA	.0008 - .006	.004 - .060	●	●
CCGT 21.51 SA	CCGT 060204 SA	.002 - .008	.004 - .095	●	●
CCGT 32.50 SA	CCGT 09T301 SA	.0008 - .006	.004 - .100	●	●
CCGT 32.50.5 SA	CCGT 09T302 SA	.0008 - .006	.004 - .100	●	●
CCGT 32.51 SA	CCGT 09T304 SA	.002 - .008	.008 - .100	●	●

● = P ● = M ● = K ● = N ● = S ○ = H

Chip-breaker design suitable for wide range of applications

Waved & sharp cutting edge induces smooth cutting

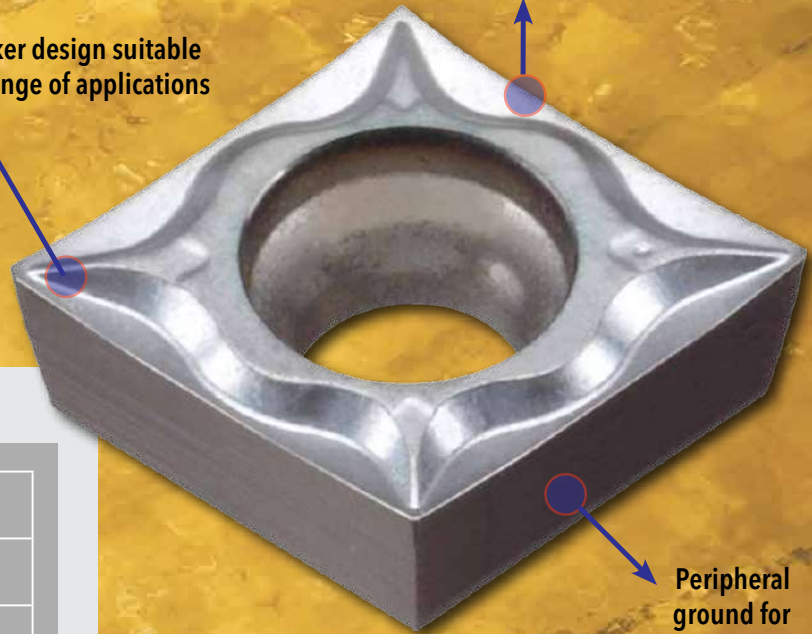

Peripheral ground for extreme accuracy

CHIP CONTROL RANGE

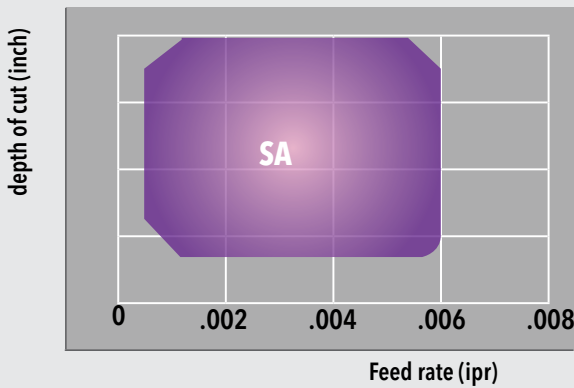

- Insert: CCGT 32.51 SA
- Cutting speed: 650 sfm
- Material: 0.45% Carbon steel

DCGT SA - 7° POSITIVE, 55° RHOMBIC GROUND INSERTS WITH SA CHIPBREAKER



ANSI Number	ISO Number	feed (ipr)	DOC (inch)	Grade	TT5080	TT9020
DCGT 21.50 SA	DCGT 070201 SA	.0008 - .006	.004 - .060	●	●	●
DCGT 21.50.5 SA	DCGT 070202 SA	.0008 - .006	.004 - .060	●	●	●
DCGT 21.51 SA	DCGT 070204 SA	.002 - .008	.004 - .060	●	●	●
DCGT 32.50 SA	DCGT 11T301 SA	.0005 - .004	.004 - .100	●	●	●
DCGT 32.50.5 SA	DCGT 11T302 SA	.0008 - .006	.004 - .100	●	●	●
DCGT 32.51 SA	DCGT 11T304 SA	.001 - .008	.004 - .100	●	●	●

● = P ● = M ● = K ● = N ● = S ● = H

TCGT SA - 7° POSITIVE, TRIANGULAR GROUND INSERTS WITH SA CHIPBREAKER



ANSI Number	ISO Number	feed (ipr)	DOC (inch)	Grade	TT5080	TT9020
TCGT 21.50 SA	TCGT 110201 SA	.0005 - .004	.004 - .100	●	●	●
TCGT 21.50.5 SA	TCGT 110202 SA	.0008 - .006	.008 - .100	●	●	●
TCGT 21.51 SA	TCGT 110204 SA	.001 - .008	.008 - .100	●	●	●

● = P ● = M ● = K ● = N ● = S ○ = H

VBGT SA - 5° POSITIVE, 35° RHOMBIC GROUND INSERTS WITH SA CHIPBREAKER



ANSI Number	ISO Number	feed (ipr)	DOC (inch)	Grade	TT5080	TT9020
VBGT 220 SA	VBGT 110301 SA	.0005 - .003	.004 - .060	●	●	●
VBGT 220.5 SA	VBGT 110302 SA	.0008 - .003	.008 - .060	●	●	●
VBGT 221 SA	VBGT 110304 SA	.001 - .004	.008 - .060	●	●	●

● = P ● = M ● = K ● = N ● = S ○ = H

VC GT SA - 7° POSITIVE, 35° RHOMBIC GROUND INSERTS WITH SA CHIPBREAKER



ANSI Number	ISO Number	feed (ipr)	DOC (inch)	Grade	TT5080	TT9020
VC GT 220 SA	VC GT 110301 SA	.0005 - .003	.004 - .060			
VC GT 220.5 SA	VC GT 110302 SA	.0008 - .003	.008 - .060			
VC GT 221 SA	VC GT 110304 SA	.001 - .004	.008 - .060			

● = P ● = M ● = K ● = N ● = S ○ = H

TOTURN™

KT CHIPBREAKER FOR ROUGH TURNING OF CAST IRON

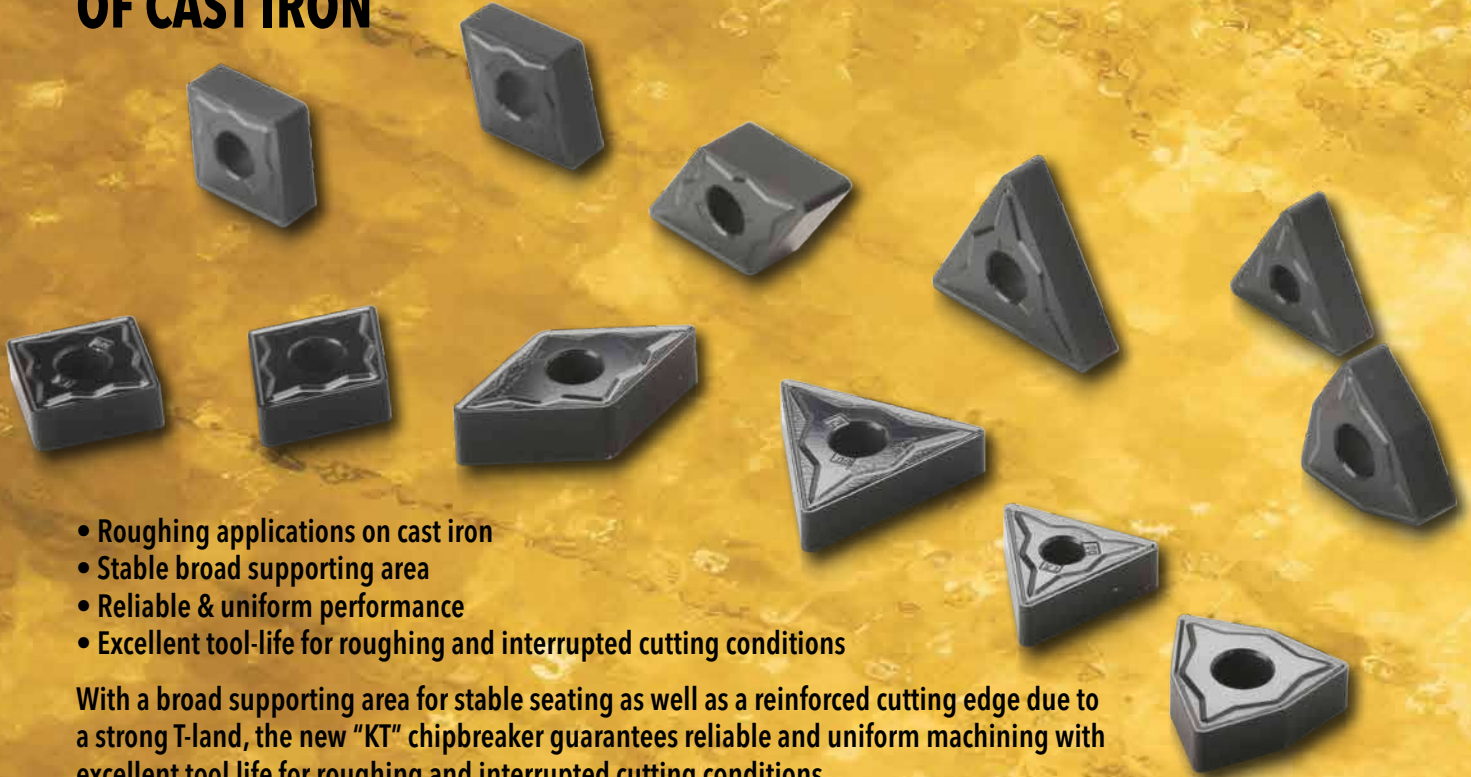

- Roughing applications on cast iron
- Stable broad supporting area
- Reliable & uniform performance
- Excellent tool-life for roughing and interrupted cutting conditions

With a broad supporting area for stable seating as well as a reinforced cutting edge due to a strong T-land, the new "KT" chipbreaker guarantees reliable and uniform machining with excellent tool life for roughing and interrupted cutting conditions.



KT CHIPBREAKERS

Insert	ANSI Number	ISO Number	feed (ipr)	DOC (inch)	Grade	TT7005	TT7015
	CNMG432KT	CNMG120408KT	0.007 - 0.021	0.015 - 0.276	•	•	
	CNMG433KT	CNMG120412KT	0.010 - 0.028	0.020 - 0.276	•	•	
	CNMG434KT	CNMG120416KT	0.011 - 0.033	0.030 - 0.276	•	•	
	DNMG432KT	DNMG150408KT	0.007 - 0.019	0.015 - 0.276	•	•	
	DNMG442KT	DNMG150608KT	0.007 - 0.019	0.015 - 0.276	•	•	
	DNMG433KT	DNMG150412KT	0.009 - 0.025	0.020 - 0.276	•	•	
	DNMG443KT	DNMG150612KT	0.009 - 0.025	0.020 - 0.276	•	•	
	SNMG432KT	SNMG120408KT	0.007 - 0.021	0.015 - 0.276	•	•	
	SNMG433KT	SNMG120412KT	0.011 - 0.028	0.020 - 0.276	•	•	
	TNMG332KT	TNMG160408KT	0.007 - 0.017	0.013 - 0.244	•	•	
	TNMG333KT	TNMG160412KT	0.008 - 0.022	0.018 - 0.248	•	•	
	TNMG432KT	TNMG220408KT	0.007 - 0.021	0.015 - 0.276	•	•	
	TNMG433KT	TNMG220412KT	0.010 - 0.028	0.020 - 0.276	•	•	
	WNMG432KT	WNMG080408KT	0.007 - 0.019	0.011 - 0.217	•	•	
	WNMG433KT	WNMG080412KT	0.009 - 0.025	0.015 - 0.217	•	•	

● = P ● = M ● = K ● = N ● = S ○ = H

CROSS SECTION VIEW

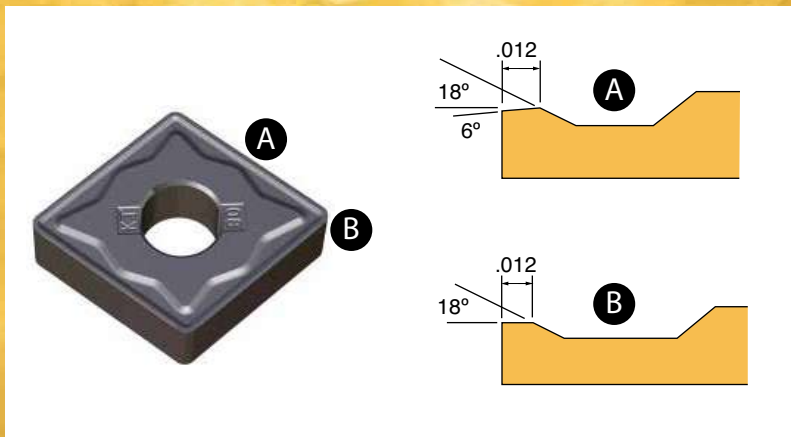



HF CHIPBREAKER FOR HIGH FEED MACHINING ECONOMY

- Utilizes double-sided technology with 6 cutting edges!
- Reduces cycle time, increases productivity
- Double-sided insert offers economical advantages when compared to competitor's inserts

PERFORMANCE

- Optimized chip-breaker geometry designed for high feed machining, up to .118 inches per revolution (3mm/rev)
- Reduced cutting forces and surprisingly smooth cutting action due to a positive, but strong, cutting edge
- Chip thinning principle reduces depth of cut notching, prolonging tool life
- Increased clamping stability from unique and patented, 3-dimensional seat design that works in conjunction with rest pads on insert
- Hook designed lever lock system provides multidirectional clamping force

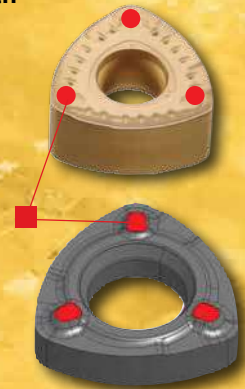

■ BNMX HF

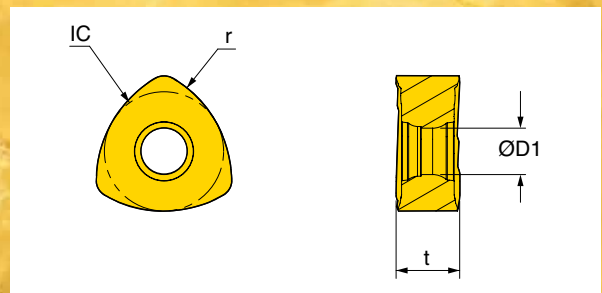

ANSI Number	ISO Number	feed (ipr)	DOC (inch)	Dimensions (inch)				Grade	T18115	T18125	T19080
				IC	t	r	D1				
BNMX 150720R/L HF	BNMX 150720R/L HF	.020 - .118	.020 - .100	.590	.315	.590	2.44	●	●	●	

● = P ● = M ● = K ● = N ● = S ○ = H



CLAMPING FEATURES OF INSERT

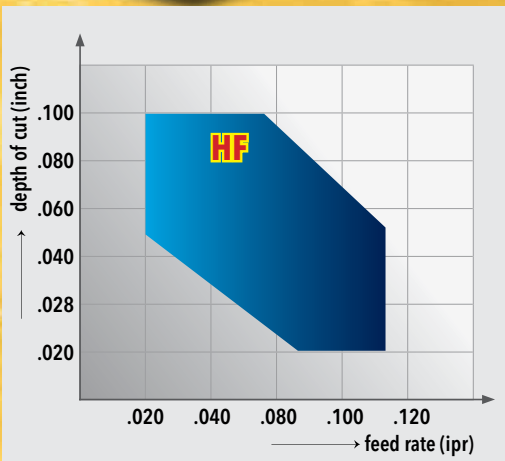
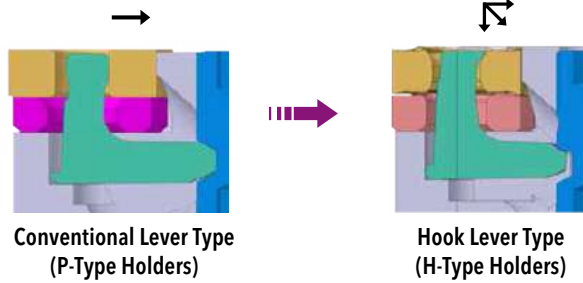

- Insert: BNMX 150720 R-HF
- Cutting speed: 500 sfm
- Material: 0.45% Carbon Steel

HBXNR/L

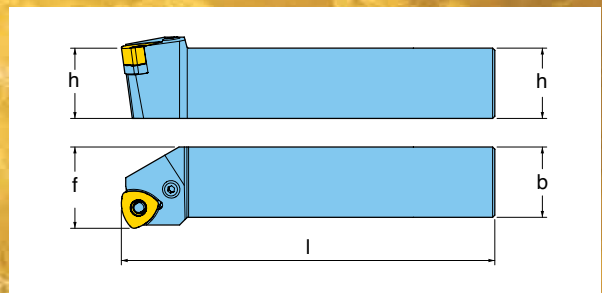
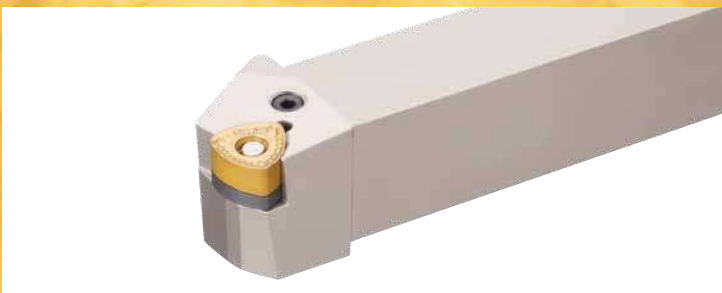

DESIGNATION	Dimensions (inch)				Insert	Lever	Screw	Shim	Shim Pin	Shim Pin Punch	Wrench
	h	b	l	f							
HBXNR/L16-55D	1.00	1.00	6.00	1.15	BNMX 150720R/L-HF	LCL 16-NX	LCS 5-L25.5	LSB 53 R/L	LSP 5	SPP 5-6	L-W3
HBXNR/L20-55E	1.25	1.25	7.00	1.45	BNMX 150720R/L-HF	LCL 16-NX	LCS 5-L25.5	LSB 53 R/L	LSP 5	SPP 5-6	L-W3



BACK CLAMPING HOLDER QUICK CHANGE HOLDER FOR SWISS TYPE LATHES

- Quick insert changeover with simple lever clamp design
- Both front and side clamping is available with each holder
- Holders use a unique backward and downward multi-directional clamping force
- No limitations - can be used with all Swiss-type turning machines

BCLCR/L-SH

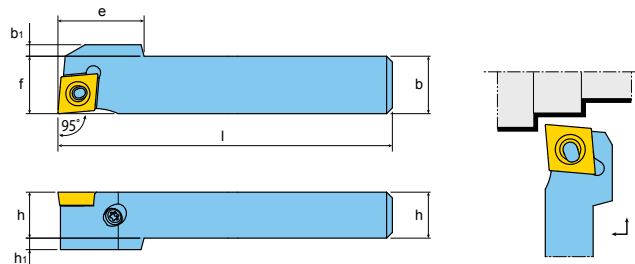

INCH DESIGNATION	Dimensions (inch)												
	h	h1	b	b1	l	f	e						
BCLCR/L06-2C-SH	.375	.079	.375	.079	5.00	.375	.591		BLCL 2	BLCS 2	BLSR 2	T 6	
BCLCR/L08-2C-SH	.500		.500		5.00	.500			BLCL 2	BLCS 2	BLSR 2	T 6	
BCLCR/L083C-SH	.500		.500	.079	5.00	.500	.669		BLCL 3	BLCS 3	BLSR 3	L-W 2F	
BCLCR/L10-3C-SH	.625		.625		5.00	.625			BLCL 3	BLCS 3	BLSR 3	L-W 2F	

METRIC DESIGNATION	Dimensions (mm)												
	h	h1	b	b1	l	f	e						
BCLCR/L1212 K06-SH	12	1	12	2	125	12			BLCL 2	BLCS 2	BLSR 2	T 6	
BCLCR/L1212 K09-SH	12	1	12	2	125	12	17		BLCL 3	BLCS 3	BLSR 3	L-W 2F	

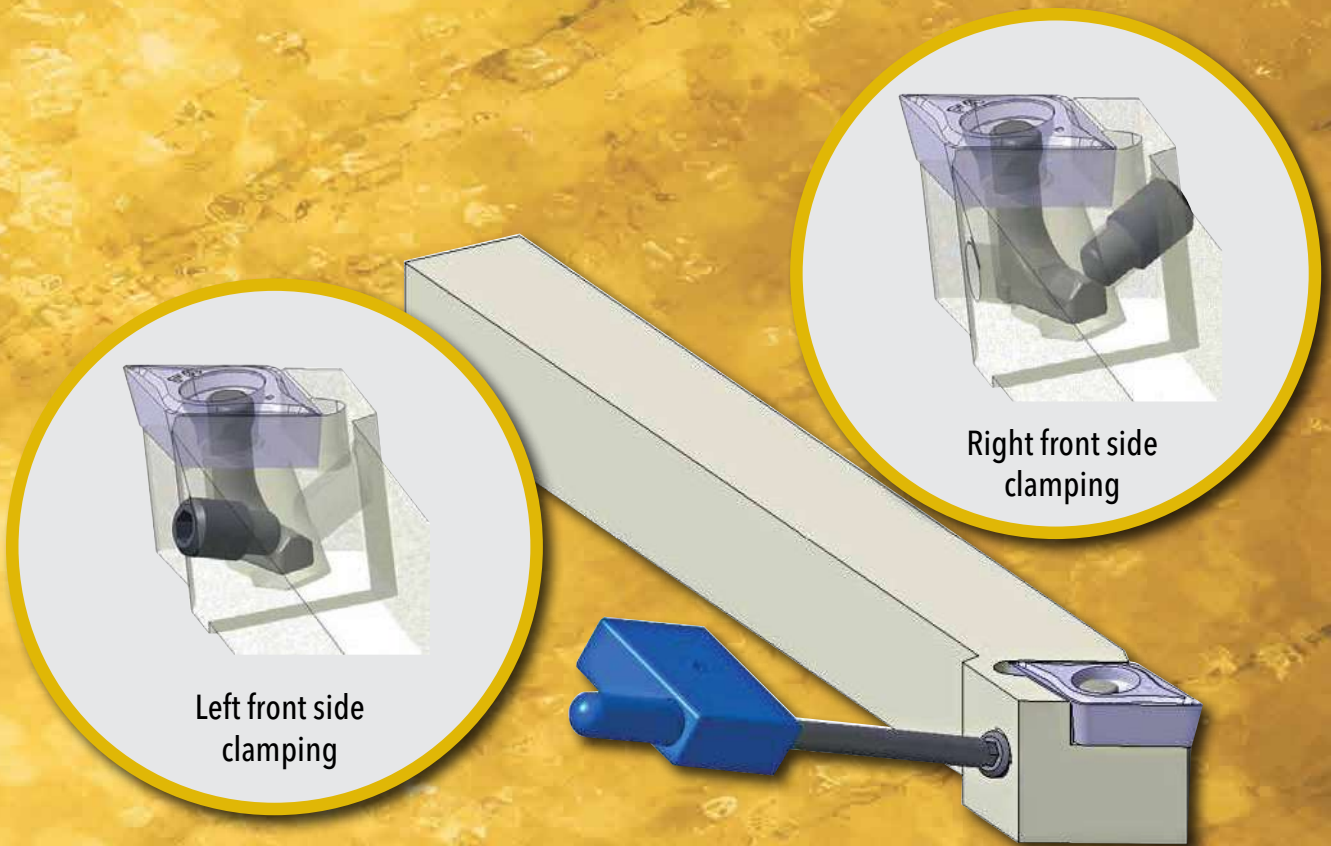

BDJCR/L-SH

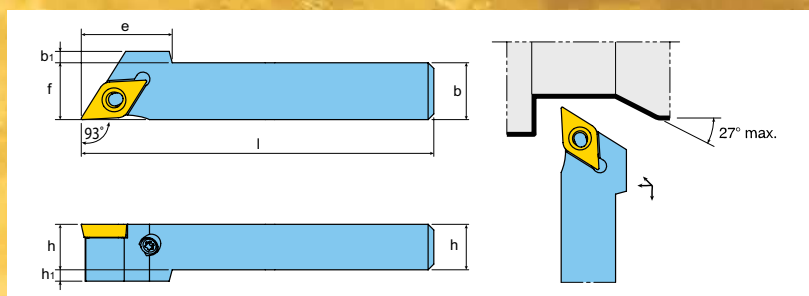

DESIGNATION	Dimensions (inch)							Insert	Lever	Lever Screw	Snap Ring	Wrench
	h	h1	b	b1	l	f	e					
BDJCR/L 06-2C-SH	.375	.079	.375	.079	5.00	.375	.591	DC□T 21.5□	BLCL 2	BLCS 2	BLSR 2	T 6
BDJCR/L 08-2C-SH	.500		.500		5.00	.500		DC□T 21.5□	BLCL 2	BLCS 2	BLSR 2	T 6
BDJCR/L 08-3C-SH	.500		.500	.079	5.00	.500	.669	DC□T 32.5□	BLCL 3	BLCS 3	BLSR 3	L-W 2F
BDJCR/L 10-3C-SH	.625		.625		5.00	.625		DC□T 32.5□	BLCL 3	BLCS 3	BLSR 3	L-W 2F

DESIGNATION	Dimensions (mm)							Insert	Lever	Lever Screw	Snap Ring	Wrench
	h	h1	b	b1	l	f	e					
BDJCR/L 1212 K07-SH	12	-	12	-	125	12	-	DC□T 0702□□	BLCL 2	BLCS 2	BLSR 2	T 6
BDJCR/L 1212 K11-SH	12	1	12	2	125	12	20	DC□T 11T3□□	BLCL 3	BLCS 3	BLSR 3	L-W 2F

BDNCN-SH

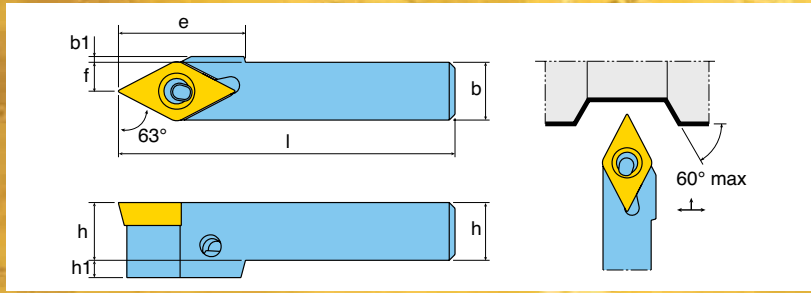

INCH		Dimensions (inch)							55°	Lever	Lever Screw	Snap Ring	Wrench
DESIGNATION	h	h1	b	b1	l	f	e	Insert					
BDNCN 06-2C-SH	.375		.375		5.00	.186		DC□T 21.5□	BLCL 2	BLCS 2	BLSR 2	T 6	
BDNCN 08-3C-SH	.500	.039	.500		5.00	.250		DC□T 32.5□	BLCL 3	BLCS 3	BLSR 3	L-W 2F	
BDNCN 10-3C-SH	.625		.625		5.00	.313		DC□T 32.5□	BLCL 3	BLCS 3	BLSR 3	L-W 2F	

METRIC		Dimensions (mm)							55°	Lever	Lever Screw	Snap Ring	Wrench
DESIGNATION	h	h1	b	b1	l	f	e	Insert					
BDNCN 1212 K07-SH	12	-	12	-	125	6		DC□T 0702□□	BLCL 2	BLCS 2	BLSR 2	T 6	
BDNCN 1212 K11-SH	12	1	12	-	125	6	22	DC□T 11T3□□	BLCL 3	BLCS 3	BLSR 3	L-W 2F	

BVJBR/L-SH

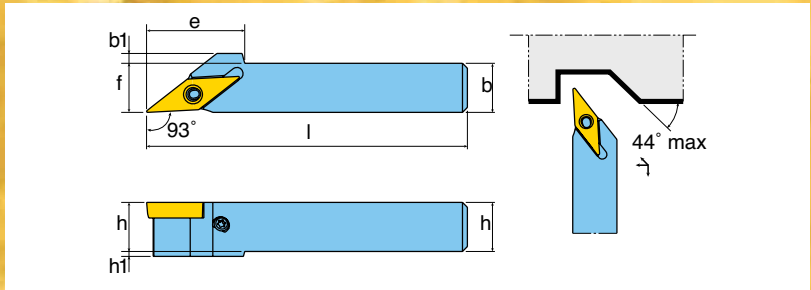

INCH		Dimensions (inch)							35°	Lever	Lever Screw	Snap Ring	Wrench
DESIGNATION	h	h1	b	b1	l	f	e	Insert					
BVJBR/L06-2C-SH	.375	.039	.375	.079	5.00	.375	.787	VB□T 22□	BLCL 2	BLCS 2	BLSR 2	T 6	
BVJBR/L08-2C-SH	.500		.500		5.00	.500		VB□T 22□	BLCL 2	BLCS 2	BLSR 2	T 6	
BVJBR/L10-2C-SH	.625		.625		5.00	.625		VB□T 22□	BLCL 2	BLCS 2	BLSR 2	T 6	

METRIC		Dimensions (mm)							35°	Lever	Lever Screw	Snap Ring	Wrench
DESIGNATION	h	h1	b	b1	l	f	e	Insert					
BVJBR/L1212 K11-SH	12		12		125	12	-	VB□T 1103□□	BLCL 2	BLCS 2	BLSR 2	T 6	

BVJCR/L-SH

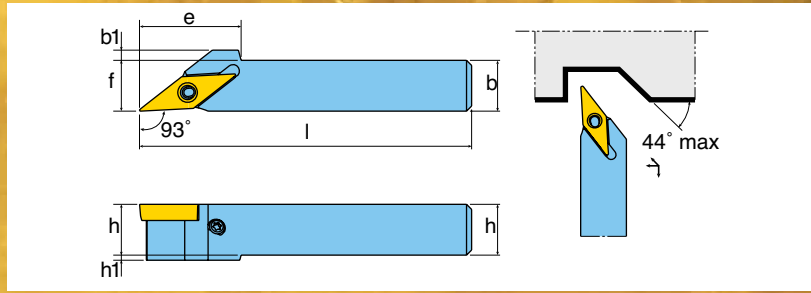

INCH		Dimensions (inch)											
DESIGNATION	h	h1	b	b1	l	f	e	Insert	Lever	Lever Screw	Snap Ring	Wrench	
BVJCR/L06-2C-SH	.375	.039	.375	.079	5.00	.375	.787	VC□T22□	BLCL 2	BLCS 2	BLSR 2	T 6	
BVJCR/L08-2C-SH	.500		.500		5.00	.500		VC□T22□	BLCL 2	BLCS 2	BLSR 2	T 6	
BVJCR/L10-2C-SH	.625		.625		5.00	.625		VC□T22□	BLCL 2	BLCS 2	BLSR 2	T 6	

METRIC		Dimensions (mm)											
DESIGNATION	h	h1	b	b1	l	f	e	Insert	Lever	Lever Screw	Snap Ring	Wrench	
BVJCR/L1212 K11-SH	12		12		125	12	-	VC□T1103□□	BLCL 2	BLCS 2	BLSR 2	T 6	



NEW INDEXABLE SYSTEM OF BORING BARS AND INSERTS FOR SMALL COMPONENT MACHINING

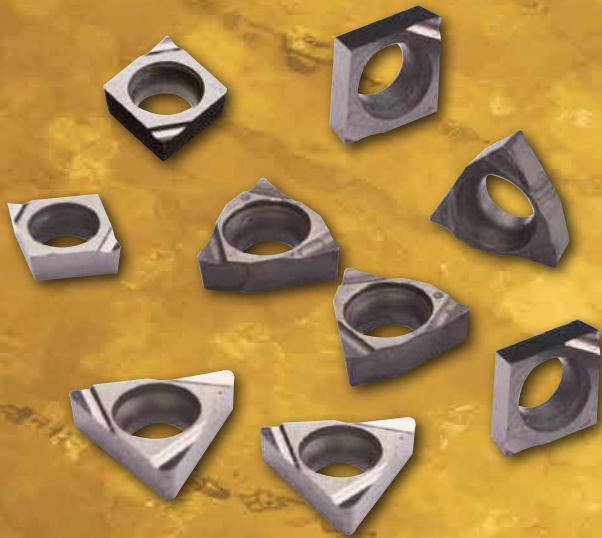

T•MINI Boring Bars

- Minimum bore diameter as small as .197" (5mm)
- Available with carbide and steel shanks, right hand and left hand
- Special design near the joints ensures improved durability
- Very good chip evacuation
- Stable machining with minimal vibration

T•MINI Inserts

- Shapes available: CCGT, TBGT, WBGT, VCGT and VCMT
- Insert IC (inscribed circle) as small as .156" (3.97mm)
- Smooth cutting edge prevents micro chipping and prolongs tool life
- Available in right hand and left hand styles (Note: right hand inserts for left hand bars. Left hand inserts for right hand bars. VCGT & VCMT inserts are neutral and will fit either hand bar).

To meet the increasing demand for boring small parts such as machined medical implant devices and micro-sized electronic components, Ingersoll introduces a new line of miniature, indexable boring bars and inserts.

The unique T•MINI boring bar configuration improves chip evacuation and can be applied in boring applications where the minimum bore diameter is as small as .197" (5mm). Optional 16mm and .625" sleeves are available to provide a simple and secure means of holding of the boring bars.

T•MINI inserts feature sharp cutting edges that help lower cutting forces and vibration. This enables precision turning and excellent surface finish capabilities. Inserts are available in ground and pressed versions depending on the shape, and contain a smooth, homogenous surface finish that prevents chipping while extending tool life.

C-SCLCR/L (CARBIDE SHANK)

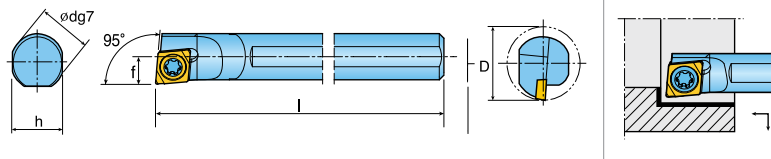

DESIGNATION	R	L	d	Dimensions (inch)				ϕD min	Insert	Screw	Wrench
				h	l	f					
C04G-SCLCR/L 03-D05	•	•	.157 (4mm)	.148	3.54	.098	.197 (5mm)	CC□T1.10.9□□ (CC□T 0301□□)	TS 16031I	T 6	
C05H-SCLCR/L 03-D06	•	•	.197 (5mm)	.187	3.94	.098	.236 (6mm)				
C06J-SCLCR/L 04-D07	•	•	.236 (6mm)	.217	4.33	.098	.276 (7mm)	CC□T1.41.1□□ (CC□T 0401□□)	TS 20038I/ HG-P	T 6P	
C07K-SCLCR/L 04-D08	•	•	.276 (7mm)	.256	4.92	.098	.315 (8mm)				

• Marked: Standard items
L-hand insert for R-hand toolholder, R-hand insert for L-hand toolholder

S-SCLCR/L (STEEL SHANK)

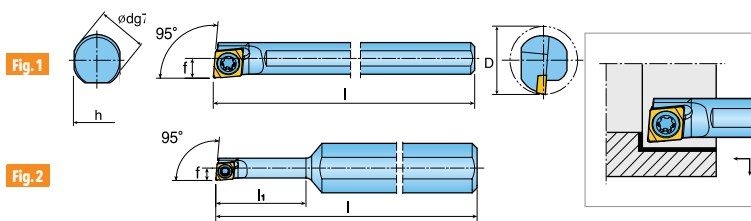



DESIGNATION	R	L	d	Dimensions (inch)				ϕD min	Insert	Screw	Wrench	SHAPE
				h	l	l1	f					
S04F-SCLCR/L 03-D05	•	•	.157 (4mm)	.148	3.15	.098	.197 (5mm)	CC□T1.10.9□□ (CC□T 0301□□)	TS 16031I	T 6	Fig 1	
S05G-SCLCR/L 03-D06	•	•	.197 (5mm)	.187	3.54	.118	.236 (6mm)					
S06H-SCLCR/L 04-D07	•	•	.236 (6mm)	.217	3.94	.138	.276 (7mm)	CC□T1.41.1□□ (CC□T 0401□□)	TS 20038I/ HG-P	T 6P	Fig 1	
S07J-SCLCR/L 04-D08	•	•	.276 (7mm)	.256	4.33	.157	.315 (8mm)					
S10H-SCLCR/L 03-D05	•	•	.394 (10mm)	.354	3.94	.591	.098	.197 (5mm)	CC□T1.10.9□□ (CC□T 0301□□)	TS 16031I	T 6	Fig 2

• Marked: Standard items
L-hand insert for R-hand toolholder, R-hand insert for L-hand toolholder

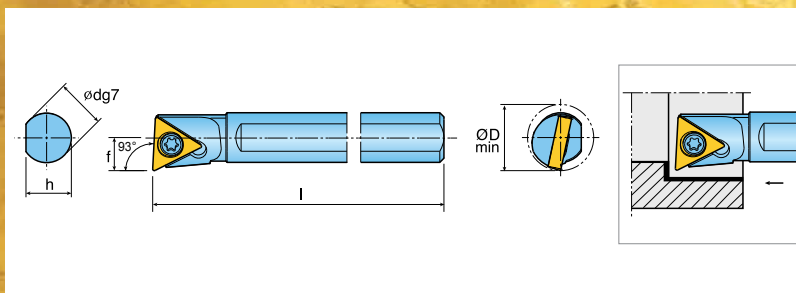
C-STUBR/L (CARBIDE SHANK)





DESIGNATION	R	L	Dimensions (inch)					ØD min	 Insert	 Screw	 Wrench
			d	h	l	f					
C06J-STUBR/L 06-D08	•	•	.236 (6mm)	.217	4.33	.157	.315 (8mm)	TB□T1.21□□ (TB□T 0601□□)	TS 20043I/ HG-P	T 6P	

• Marked: Standard items
L-hand insert for R-hand toolholder, R-hand insert for L-hand toolholder

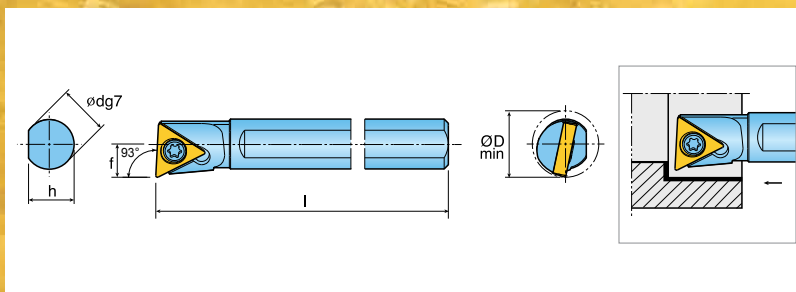
S-STUBR/L (STEEL SHANK)





DESIGNATION	R	L	Dimensions (inch)					ØD min	 Insert	 Screw	 Wrench
			d	h	l	f					
S06H-STUBR/L 06-D08	•	•	.236 (6mm)	.217	3.94	.157	.315 (8mm)	TB□T1.21□□ (TB□T 0601□□)	TS 20043I/ HG-P	T 6P	

• Marked: Standard items
L-hand insert for R-hand toolholder, R-hand insert for L-hand toolholder

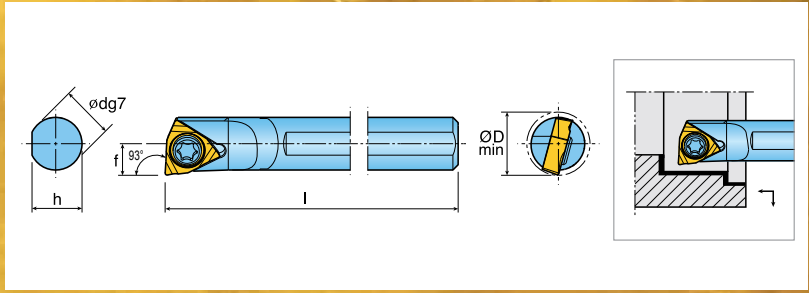
C-SWUBR/L (CARBIDE SHANK)





DESIGNATION	R	L	d	Dimensions (inch)				ØD min	 Insert	 Screw	 Wrench
				h	l	f					
C05H-SWUBR/L 06-D06	•	•	.197 (5mm)	.187	3.94	.118	.236 (6mm)	WB□T1.21□□ (WB□T 0601□□)	TS 200381/ HG-P	T 6P	
C06J-SWUBR/L 06-D07	•	•	.236 (6mm)	.217	4.33	.138	.276 (7mm)				
C07K-SWUBR/L 06-D08	•	•	.276 (7mm)	.256	4.92	.157	.315 (8mm)				

• Marked: Standard items
L-hand insert for R-hand toolholder, R-hand insert for L-hand toolholder

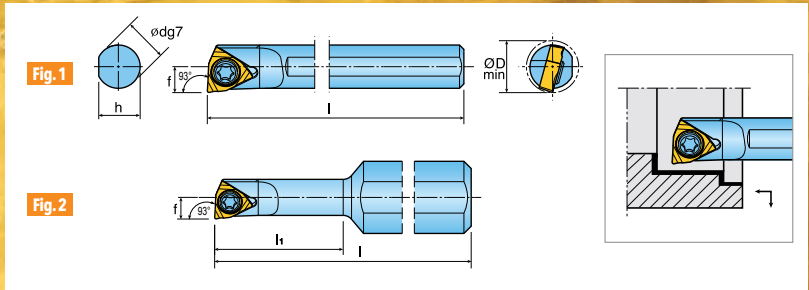
S-SWUBR/L (STEEL SHANK)





DESIGNATION	R	L	d	Dimensions (inch)				ØD min	 Insert	 Screw	 Wrench	SHAPE
				h	l	l1	f					
S05G-SWUBR/L 06-D06	•	•	.197 (5mm)	.187	3.54	-	.118	.236 (6mm)	WB□T1.21□□ (WB□T 0601□□)	TS 200381/ HG-P	T 6P	Fig 1
S06H-SWUBR/L 06-D07	•	•	.236 (6mm)	.217	4.33	-	.138	.276 (7mm)				
S07J-SWUBR/L 06-D08	•	•	.276 (7mm)	.256	4.33	-	.157	.315 (8mm)				
S10H-SWUBR/L 06-D06	•	•	.394 (10mm)	.354	3.94	.709	.118	.236 (6mm)				Fig 2

• Marked: Standard items
L-hand insert for R-hand toolholder, R-hand insert for L-hand toolholder

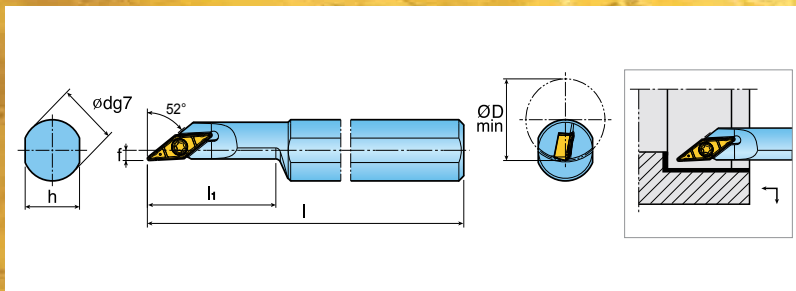
S-SVJCR/L (STEEL SHANK)





DESIGNATION	R	L	d	Dimensions (inch)				$\phi D min$			
				h	l	l1	f				
S12M-SVJCR/L 08-D16	•	•	.472 (12mm)	.433	5.91	1.02	.079	.630 (16mm)	VC□T1.51.5□□ (VC□T 0802□□)	TS 20038/ HG-P	T 6P
S16Q-SVJCR/L 08-D20	•	•	.630 (16mm)	.591	7.09	1.42	.079	.787 (20mm)			

• Marked: Standard items

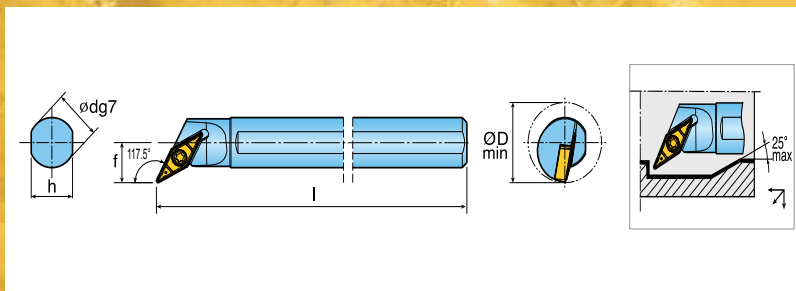
S-SVPCR/L (STEEL SHANK)





DESIGNATION	R	L	d	Dimensions (inch)				$\phi D min$			
				h	l	f	Insert				
S10K-SVPCR/L 08-D16	•	•	.394 (10mm)	.354	4.92	.236	.630 (16mm)	VC□T1.51.5□□ (VC□T 0802□□)	TS 20038/ HG-P	T 6P	
S12M-SVPCR/L 11-D20	•	•	.472 (12mm)	.433	5.91	.394	.787 (20mm)				VC□T 22□□ (VC□T 1103□□)

• Marked: Standard items

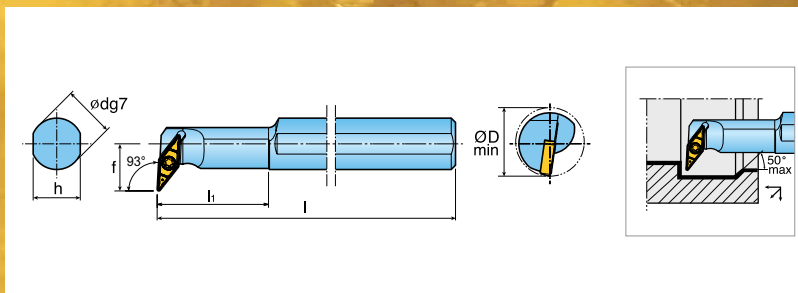
S-SVUCR/L (STEEL SHANK)



DESIGNATION	R	L	Dimensions (inch)						$\phi D \text{ min}$	 Insert	 Screw	 Wrench
			d	h	l	l1	f					
S12M-SVUCR/L 08-D16	•	•	.472 (12mm)	.433	5.91	1.02	.433	.630 (16mm)	VC□T1.51.5□□ (VC□T 0802□□)	TS 20038I/HG-P	T 6P	
S16Q-SVUCR/L 11-D20	•	•	.630 (16mm)	.591	7.09	1.26	.610	.787 (20mm)	VC□T 22□□ (VC□T 1103□□)	SO 25065I	T 7	
S20R-SVUCR/L 11-D25	•	•	.787 (20mm)	.709	7.87	1.57	.689	.984 (25mm)				

• Marked: Standard items

TSL (SLEEVE)

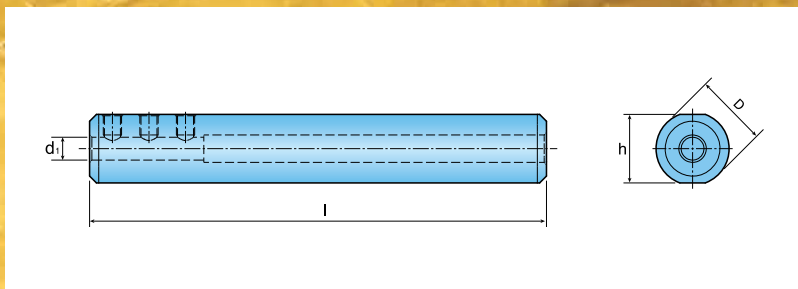



DESIGNATION		Dimensions				 Screw	 Wrench
		d1	h	l	D		
Metric	TSL 16-04	•	.157 (4mm)	15	100	SS M4 x 0.7 x 4	L-W2
	TSL 16-05	•	.197 (5mm)	15	100		
	TSL 16-06	•	.236 (6mm)	15	100		
	TSL 16-07	•	.276 (7mm)	15	100		
Inch	TSL15.88-04-mini	•	.157 (4mm)	5.91	3.94	SS M4 x 0.7 x 4	L-W2
	TSL15.88-05-mini	•	.197 (5mm)	5.91	3.94		
	TSL15.88-06-mini	•	.236 (6mm)	5.91	3.94		
	TSL15.88-07-mini	•	.276 (7mm)	5.91	3.94		

• Marked: Standard items

INSERTS

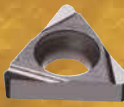
- P** Carbon Steel C: 0.45%
- M** Austenitic Stainless Steel
- K** High Tensile Cast Iron
- N** Aluminum
- S** Inconel
- H** Hardened Steel

INSERT	ANSI DESIGNATION	ISO DESIGNATION	Dimensions (inches)				Grade	CT3000	PV3010	TT8115	TT8125	TT9225	TT5100	TT5080	TT9020
			I.C.	Rad	Feed (ipr)	DOC									
 CCGT 03, 04	CCGT 0301003 R-FF	CCGT 1.10.9XR-FF	0.138	0.001	.001 - .004	.002 - .012									
	CCGT 0301003 L-FF	CCGT 1.10.9XL-FF	0.138	0.001	.001 - .004	.002 - .012									
	CCGT 030101 R-FF	CCGT 1.10.90XR-FF	0.138	0.004	.001 - .005	.003 - .016									
	CCGT 030101 L-FF	CCGT 1.10.90XL-FF	0.138	0.004	.001 - .005	.003 - .016									
	CCGT 030102 R-FF	CCGT 1.10.90.5R-FF	0.138	0.008	.001 - .006	.004 - .016									
	CCGT 030102 L-FF	CCGT 1.10.90.5L-FF	0.138	0.008	.001 - .006	.004 - .016									
	CCGT 030104 R-FF	CCGT 1.10.91R-FF	0.138	0.016	.002 - .008	.004 - .016									
	CCGT 030104 L-FF	CCGT 1.10.91L-FF	0.138	0.016	.002 - .008	.004 - .016									
	CCGT 0401003 R-FF	CCGT 1.41.1XR-FF	0.169	0.001	.001 - .004	.002 - .016									
	CCGT 0401003 L-FF	CCGT 1.41.1XL-FF	0.169	0.001	.001 - .004	.002 - .016									
	CCGT 040101 R-FF	CCGT 1.41.10R-FF	0.169	0.004	.001 - .005	.004 - .020									
	CCGT 040101 L-FF	CCGT 1.41.10L-FF	0.169	0.004	.001 - .005	.004 - .020									
	CCGT 040102 R-FF	CCGT 1.41.10.5R-FF	0.169	0.008	.001 - .005	.004 - .020									
	CCGT 040102 L-FF	CCGT 1.41.10.5L-FF	0.169	0.008	.001 - .005	.004 - .020									
	CCGT 040104 R-FF	CCGT 1.41.11R-FF	0.169	0.016	.002 - .008	.004 - .020									
	CCGT 040104 L-FF	CCGT 1.41.11L-FF	0.169	0.016	.002 - .008	.004 - .020									
 TBGT 06	TBGT 0601003 R-FF	TBGT 1.21XR-FF	0.156	0.001	.001 - .004	.002 - .012									
	TBGT 0601003 L-FF	TBGT 1.21XL-FF	0.156	0.001	.001 - .004	.002 - .012									
	TBGT 060101 R-FF	TBGT 1.210R-FF	0.156	0.004	.001 - .005	.003 - .016									
	TBGT 060101 L-FF	TBGT 1.210L-FF	0.156	0.004	.001 - .005	.003 - .016									
	TBGT 060102 R-FF	TBGT 1.210.5R-FF	0.156	0.008	.001 - .006	.004 - .016									
	TBGT 060102 L-FF	TBGT 1.210.5L-FF	0.156	0.008	.001 - .006	.004 - .016									
	TBGT 060104 R-FF	TBGT 1.211R-FF	0.156	0.016	.002 - .008	.004 - .016									
	TBGT 060104 L-FF	TBGT 1.211L-FF	0.156	0.016	.002 - .008	.004 - .016									
 WBGT 06	WBGT 0601003 R-FF	WBGT 1.21XR-FF	0.156	0.001	.001 - .004	.002 - .012									
	WBGT 0601003 L-FF	WBGT 1.21XL-FF	0.156	0.001	.001 - .004	.002 - .012									
	WBGT 060101 R-FF	WBGT 1.210R-FF	0.156	0.004	.001 - .005	.003 - .016									
	WBGT 060101 L-FF	WBGT 1.210L-FF	0.156	0.004	.001 - .005	.003 - .016									
	WBGT 060102 R-FF	WBGT 1.210.5R-FF	0.156	0.008	.001 - .006	.004 - .016									
	WBGT 060102 L-FF	WBGT 1.210.5L-FF	0.156	0.008	.001 - .006	.004 - .016									
	WBGT 060104 R-FF	WBGT 1.211R-FF	0.156	0.016	.002 - .008	.004 - .016									
	WBGT 060104 L-FF	WBGT 1.211L-FF	0.156	0.016	.002 - .008	.004 - .016									
 VCGT 11	VCGT 110301 SA	VCGT 220 SA	0.250	0.004	.0005 - .008	.004 - .060									
	VCGT 110302 SA	VCGT 220.5 SA	0.250	0.008	.0008 - .008	.008 - .060									
	VCGT 110304 SA	VCGT 221 SA	0.250	0.016	.002 - .008	.008 - .060									
 VCMT 08,11	VCMT 080202 PC	VCMT 1.51.51 PC	0.187	0.008	.001 - .006	.008 - .060									
	VCMT 080204 PC	VCMT 1.51.51 PC	0.187	0.016	.002 - .008	.008 - .060									
	VCMT 110304 PC	VCMT 221 PC	0.250	0.016	.002 - .008	.004 - .067									

EO ADAPTER™

QUICK CHANGE HOLDERS FOR ISO TURNING

- Wide range of quick change heads for ISO turning inserts.
- Ideal for high precision machining due to stable clamping force.



C4, C5, C6-TCLNR



C4, C5, C6-SCLCR

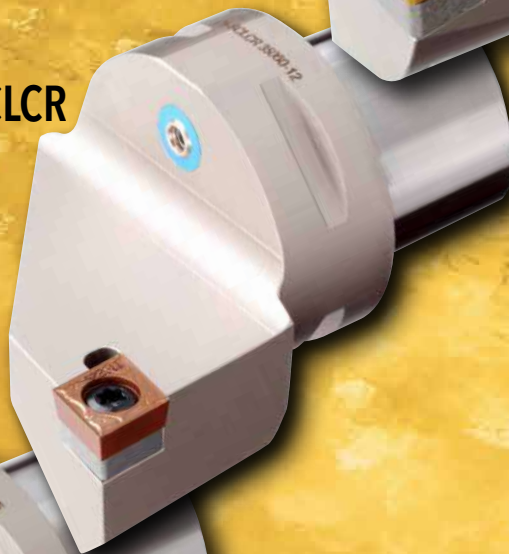







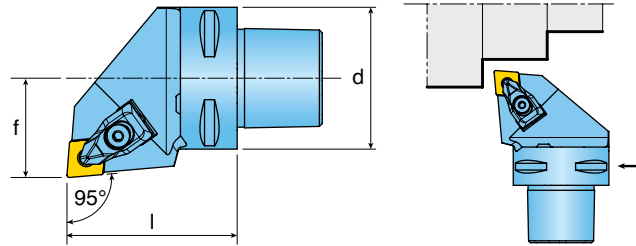

C4, C5, C6-TDJNR



C_-TCLNR/L*





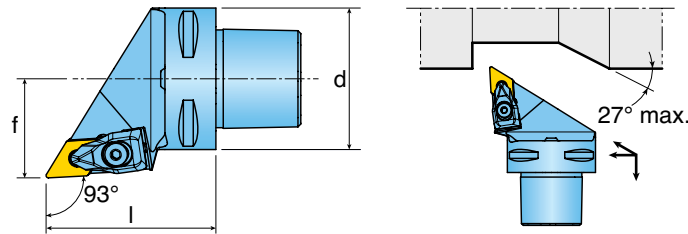

DESIGNATION	Dimensions (mm)										
	d	f	l								
C4-TCLNR/L 27050-09	40	27	50	CN□□ 33□	DLM 3	DLS 3	LSC 32	SO 40085I	DSP 3	NZ 83	L-W 2.5
C4-TCLNR/L 27050-12	40	27	50	CN□□ 43□	DLM 4	DLS 4	TSC 44	SO 40050I	DSP 4	NZ 83	L-W 3
C5-TCLNR/L 35060-12	50	35	60	CN□□ 43□	DLM 4	DLS 4	TSC 44	SO 40050I	DSP 4	NZ 104	L-W 3
C6-TCLNR/L 45065-12	63	45	65	CN□□ 43□	DLM 4	DLS 4	TSC 44	SO 40050I	DSP 4	NZ 104	L-W 3
C4-TCLNR/L 27055-16	40	27	55	CN□□ 54□	DLM 5	DLS 5	TSC 54	SO 50090I	DSP 5	NZ 83	L-W 4
C5-TCLNR/L 35060-19	50	35	60	CN□□ 64□	DLM 6	DLS 5	LSC 63	SO 80180I	DSP 5	NZ 104	L-W 4
C6-TCLNR/L 45065-19	63	45	65	CN□□ 64□	DLM 6	DLS 5	LSC 63	SO 80180I	DSP 5	NZ 104	L-W 4

compatible with Sandvik's COROMANT CAPTO (**) system.

C_-TDJNR/L*



DESIGNATION	Dimensions (mm)										
	d	f	l								
C4-TDJNR/L 27055-1504	40	27	55	DN□□ 43□	DLM 4	DLS 4	TSD 44	SO 40050I	DSP 4	NZ 83	L-W 3
C4-TDJNR/L 27055-1506	40	27	55	DN□□ 44□	DLM 4	DLS 4	TSD 43	SO 40050I	DSP 4	NZ 83	L-W 3
C5-TDJNR/L 35060-1504	50	35	60	DN□□ 43□	DLM 4	DLS 4	TSD 44	SO 40050I	DSP 4	NZ 83	L-W 3
C5-TDJNR/L 35060-1506	50	35	60	DN□□ 44□	DLM 4	DLS 4	TSD 43	SO 40050I	DSP 4	NZ 104	L-W 3
C6-TDJNR/L 45065-1504	63	45	65	DN□□ 43□	DLM 4	DLS 4	TSD 44	SO 40050I	DSP 4	NZ 83	L-W 3
C6-TDJNR/L 45065-1506	63	45	65	DN□□ 44□	DLM 4	DLS 4	TSD 43	SO 40050I	DSP 4	NZ 104	L-W 3

compatible with Sandvik's COROMANT CAPTO (**) system.

C_-TSDNN*

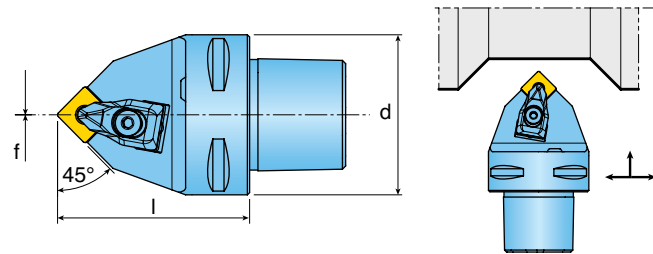

DESIGNATION	Dimensions (mm)			Insert	Clamp	Clamp Screw	Shim Screw	Spring	Nozzle	Wrench	
	d	f	l								
C4-TSDNN 00050-12	40	0	50	SN□□ 43□	DLM 4	DLS 4	TSS 44	SO 40050I	DSP 4	NZ 83	L-W 3
C5-TSDNN 00060-12	50	0	60	SN□□ 43□	DLM 4	DLS 4	TSS 44	SO 40050I	DSP 4	NZ 104	L-W 3
C6-TSDNN 00065-12	63	0	65	SN□□ 43□	DLM 4	DLS 4	TSS 44	SO 40050I	DSP 4	NZ 104	L-W 3

compatible with Sandvik's COROMANT CAPTO (**) system.

C_-TSSNR/L*

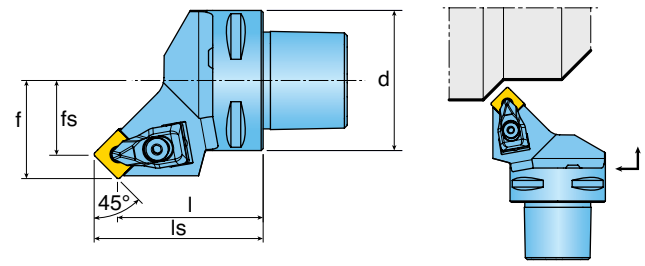

DESIGNATION	Dimensions (mm)					Insert	Clamp	Clamp Screw	Shim Screw	Spring	Nozzle	Wrench	
	d	f	fs	l	ls								
C4-TSSNR/L27042-12	40	27	18.7	42	50.3	SN□□ 43□	DLM 4	DLS 4	TSS 44	SO 40050I	DSP 4	NZ 83	L-W 3
C5-TSSNR/L35052-12	50	35	26.7	52	60.3	SN□□ 43□	DLM 4	DLS 4	TSS 44	SO 40050I	DSP 4	NZ 104	L-W 3
C6-TSSNR/L45056-12	63	45	36.7	56	64.3	SN□□ 43□	DLM 4	DLS 4	TSS 44	SO 40050I	DSP 4	NZ 104	L-W 3

compatible with Sandvik's COROMANT CAPTO (**) system.

C_-TTGNR/L C_-TTJNR/L*

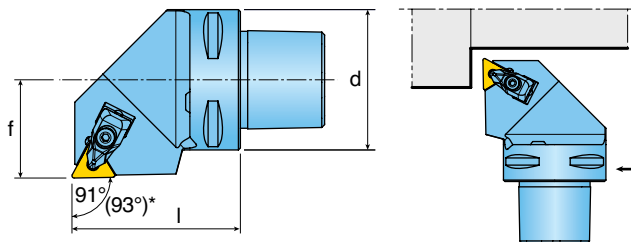

DESIGNATION	Dimensions (mm)			Insert	Clamp	Clamp Screw	Shim	Shim Screw	Spring	Nozzle	Wrench
	d	f	l								
C4-TTGNR/L27050-16	40	27	50	TN□□33□	DLM 3	DLS 3	TST 33	SO 35080I	DSP 3	NZ 83	L-W 2.5
C5-TTGNR/L35060-16	50	35	60	TN□□33□	DLM 3	DLS 3	TST 33	SO 35080I	DSP 3	NZ 104	L-W 2.5
C6-TTGNR/L45065-16	63	45	65	TN□□33□	DLM 3	DLS 3	TST 33	SO 35080I	DSP 3	NZ 104	L-W 2.5
C4-TTJNR/L27050-16	40	27	50	TN□□33□	DLM 3	DLS 3	TST 33	SO 35080I	DSP 3	NZ 83	L-W 2.5
C5-TTJNR/L35060-16	50	35	60	TN□□33□	DLM 3	DLS 3	TST 33	SO 35080I	DSP 3	NZ 104	L-W 2.5
C6-TTJNR/L45065-16	63	45	65	TN□□33□	DLM 3	DLS 3	TST 33	SO 35080I	DSP 3	NZ 104	L-W 2.5

NOTE: TTGNR/L has 91° lead angle. TTJNR/L has 93° lead angle.
compatible with Sandvik's COROMANT CAPTO (***) system.

C_-TVJNR/L*

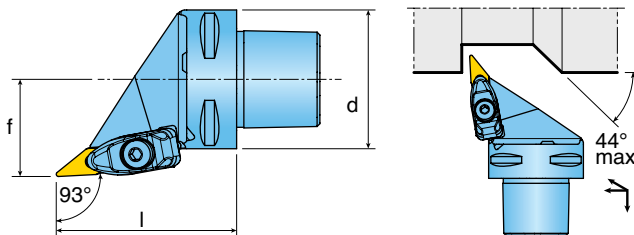

DESIGNATION	Dimensions (mm)			Insert	Clamp	Clamp Screw	Shim	Shim Screw	Spring	Nozzle	Wrench
	d	f	l								
C4-TVJNR/L27062-16	40	27	62	VN□□33□	DLM 3V	DLS 5	TSV 33	SO 35080I	DSP 5	NZ 83	L-W 4
C5-TVJNR/L35065-16	50	35	65	VN□□33□	DLM 3V	DLS 5	TSV 33	SO 35080I	DSP 5	NZ 104	L-W 4
C6-TVJNR/L45068-16	63	45	68	VN□□33□	DLM 3V	DLS 5	TSV 33	SO 35080I	DSP 5	NZ 104	L-W 4

compatible with Sandvik's COROMANT CAPTO (***) system.

C_-TWLNR/L*

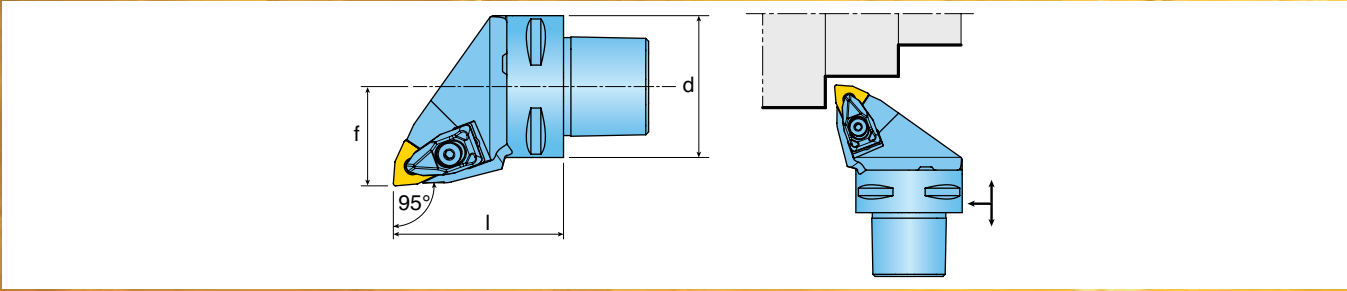

DESIGNATION	Dimensions (mm)										
	d	f	l	Insert	Clamp	Clamp Screw	Shim	Shim Screw	Spring	Nozzle	Wrench
C4-TWLNR/L27050-06	40	27	50	WN□□ 33□	DLM 3	DLS 3	PSW 32	SO 40090I	DSP 3	NZ 83	L-W 2.5
C4-TWLNR/L27050-08	40	27	50	WN□□ 43□	DLM 4	DLS 4	TSW 44	SO 40050I	DSP 4	NZ 83	L-W 3
C5-TWLNR/L35060-08	50	35	60	WN□□ 43□	DLM 4	DLS 4	TSW 44	SO 40050I	DSP 4	NZ 104	L-W 3
C6-TWLNR/L45065-08	63	45	65	WN□□ 43□	DLM 4	DLS 4	TSW 44	SO 40050I	DSP 4	NZ 104	L-W 3

compatible with Sandvik's COROMANT CAPTO (**) system.

C_-SCLCR/L*

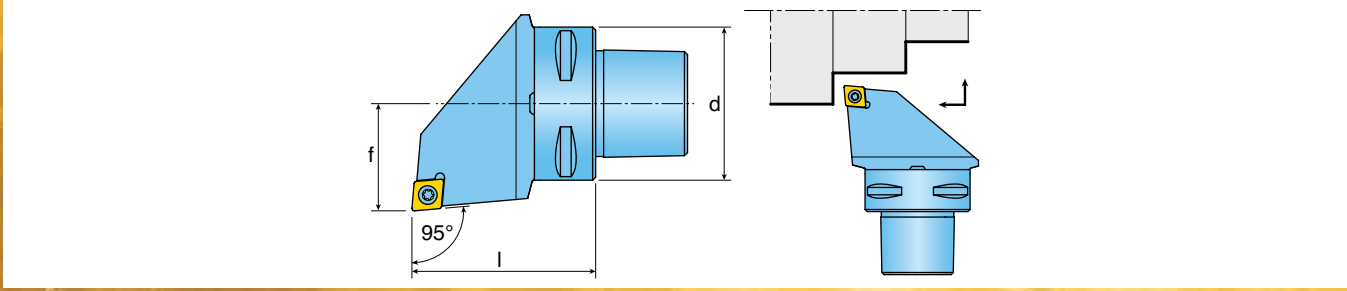





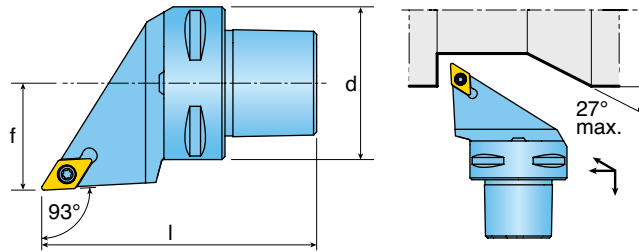

DESIGNATION	Dimensions (mm)								
	d	f	l	Insert	Screw	Shim	Shim Screw	Nozzle	Wrench
C4-SCLCR/L27050-09	40	27	50	CC□□ 32.5□	SO 35124I	SSC 32	SO 50090S	NZ 83	T 15
C5-SCLCR/L35060-09	50	35	60	CC□□ 32.5□	SO 35124I	SSC 32	SO 50090S	NZ 104	T 15
C6-SCLCR/L45065-09	63	45	65	CC□□ 32.5□	SO 35124I	SSC 32	SO 50090S	NZ 104	T 15
C4-SCLCR/L27050-12	40	27	50	CC□□ 43□	SO 45130I	SSC 43N	SO 60105S	NZ 83	T 20
C5-SCLCR/L35060-12	50	35	60	CC□□ 43□	SO 45130I	SSC 43N	SO 60105S	NZ 104	T 20
C6-SCLCR/L45065-12	63	45	65	CC□□ 43□	SO 45130I	SSC 43N	SO 60105S	NZ 104	T 20

compatible with Sandvik's COROMANT CAPTO (**) system.

C_-SDJCR/L*







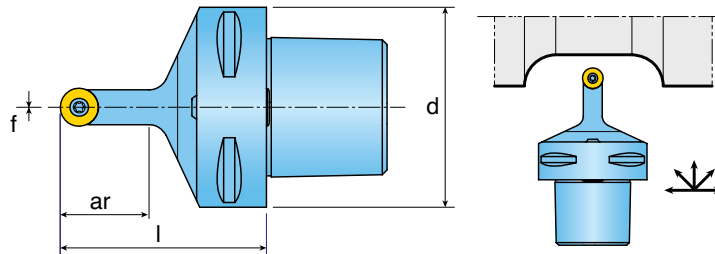

DESIGNATION	Dimensions (mm)				 Insert	 Shim	 Shim Screw	 Spring	 Nozzle	 Wrench
	d	f	l							
C4-SDJCR/L27050-11	40	27	50		DC□ 32.5□	SO 35124I	SSD 32	SO 50090S	NZ 83	T 15
C5-SDJCR/L35060-11	50	35	60		DC□ 32.5□	SO 35124I	SSD 32	SO 50090S	NZ 104	T 15
C6-SDJCR/L45065-11	63	45	65		DC□ 32.5□	SO 35124I	SSD 32	SO 50090S	NZ 104	T 15

compatible with Sandvik's COROMANT CAPTO (**) system.

C_-SRDCN*







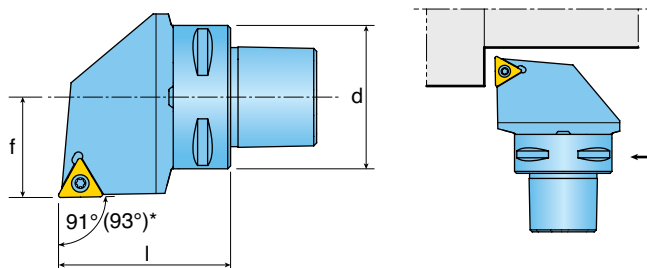

DESIGNATION	Dimensions (mm)				 Insert	 Screw	 Shim	 Shim Screw	 Nozzle	 Wrench
	d	f	l	ar						
C4-SRDCN 00050-10A	40	0	50	25	RC□ 10T300	TS 40097I	TRC 3-0	SR TC-3	NZ 83	T 15
C5-SRDCN 00060-10A	50	0	60	25	RC□ 10T300	TS 40097I	TRC 3-0	SR TC-3	NZ 104	T 15
C6-SRDCN 00065-10A	63	0	65	25	RC□ 10T300	TS 40097I	TRC 3-0	SR TC-3	NZ 104	T 15
C4-SRDCN 00050-12A	40	0	50	28	RC□ 120400	SO 40050I	TRC 4-0	SR TC-4S	NZ 83	T 15
C5-SRDCN 00060-12A	50	0	60	28	RC□ 120400	SO 40050I	TRC 4-0	SR TC-4S	NZ 104	T 15
C6-SRDCN 00065-12A	63	0	65	28	RC□ 120400	SO 40050I	TRC 4-0	SR TC-4S	NZ 104	T 15

compatible with Sandvik's COROMANT CAPTO (**) system.

■ C_-STGCR/L C_-STJCR/L*







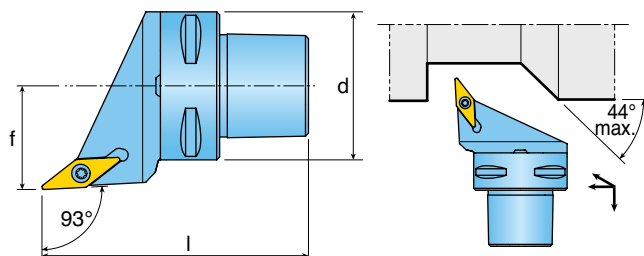

DESIGNATION	Dimensions (mm)								
	d	f	l						
C4-STGCR/L 27050-16	40	27	50	SC□T 32.5□	SO 35124I	SST 32	SO 50090S	NZ 83	T 15
C5-STGCR/L 35060-16	50	35	60	SC□T 32.5□	SO 35124I	SST 32	SO 50090S	NZ 104	T 15
C4-STJCR/L 27050-16	40	27	50	SC□T 32.5□	SO 35124I	SST 32	SO 50090S	NZ 83	T 15
C5-STJCR/L 35060-16	50	35	60	SC□T 32.5□	SO 35124I	SST 32	SO 50090S	NZ 104	T 15

NOTE: STGCR/L has 91° lead angle. STJCR/L has 93° lead angle.
compatible with Sandvik's COROMANT CAPTO (**) system.

■ C_-SVJBR/L*







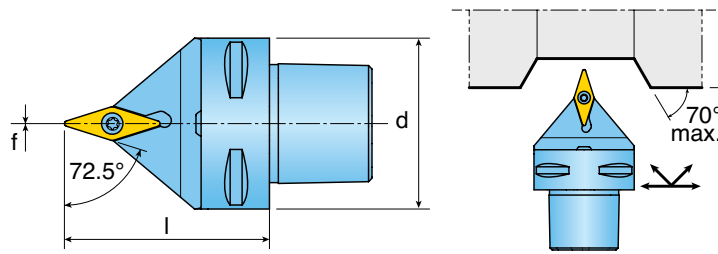

DESIGNATION	Dimensions (mm)								
	d	f	l						
C4-SVJBR/L 27050-16	40	27	50	VB□T 33□	SO 35124I	SSV 32	TS 5035062S	NZ 83	T 15
C5-SVJBR/L 35060-16	50	35	60	VB□T 33□	SO 35124I	SSV 32	TS 5035062S	NZ 104	T 15
C6-SVJBR/L 45065-16	63	35	65	VB□T 33□	SO 35124I	SSV 32	TS 5035062S	NZ 104	T 15

compatible with Sandvik's COROMANT CAPTO (**) system.

C_-SVVBN*



DESIGNATION	Dimensions (mm)			 Insert	 Screw	 Shim	 Shim Screw	 Nozzle	 Wrench
	d	f	l						
C4-SVVBN 00050-16	40	0	50	VB□T 33□	SO 35124I	SSV 32	TS 5035062S	NZ 83	T 15
C5-SVVBN 00060-16	50	0	60	VB□T 33□	SO 35124I	SSV 32	TS 5035062S	NZ 104	T 15
C6-SVVBN 00065-16	63	0	65	VB□T 33□	SO 35124I	SSV 32	TS 5035062S	NZ 104	T 15

compatible with Sandvik's COROMANT CAPTO (**) system.

COMBI CLAMP™

MULTI-FUNCTION CLAMP FOR USE WITH INGERSOLL'S EXISTING T-TYPE HOLDERS

- **Compatibility:** 100% compatible with Ingersoll's T-Type holders.
- **Versatility:** 3 different types of inserts can be used in same toolholder.
- **Durability:** New carbide clamp shows better wear resistance, especially in cast iron machining applications
- **Stability:** Due to the floating plate system in the insert's contact area, it provides much stronger and stable clamping



DCL S-4H



DCL S-4D



DCL S-4F

ex)



CN□A 43□
Insert with hole



CN□X 45□
Insert with Ingersoll dimple



CN□N 43□
Insert with no hole



Floating carbide plate

Floating carbide plate provides greater stability than conventional clamp.

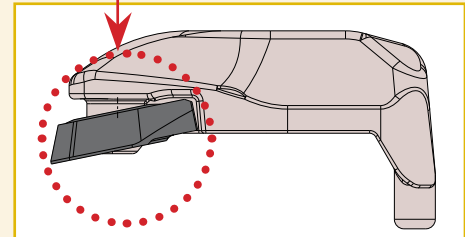
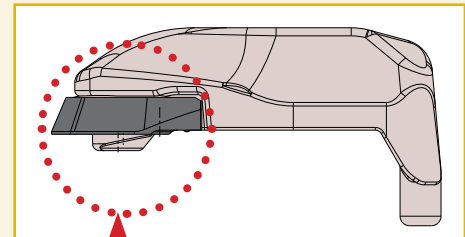

NEW CLAMP FOR MULTI-FUNCTION

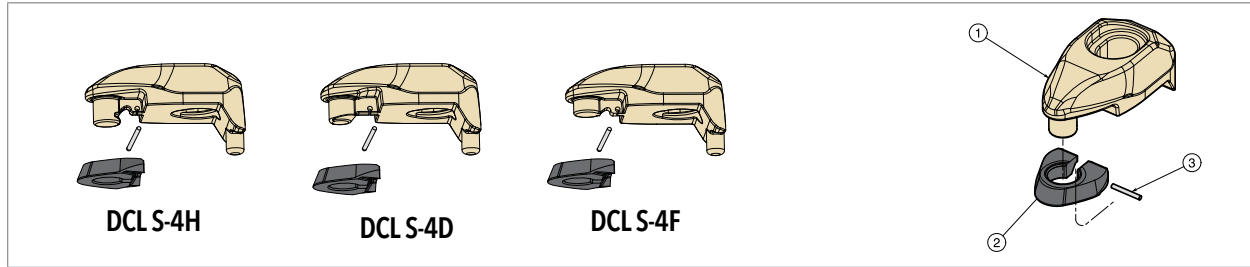

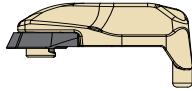
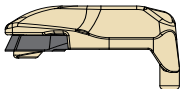
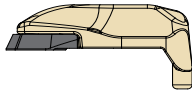
Clamp	Designation	Components			Insert	Shim
		¹ Clamp	² CTC Plate	³ PIN		
	DCLS-4H	DCL 4H	DCL 4-PL	PIN 0683	CN□A 43□	TSC 44
					DN□A 43□	TSD 44
					DN□A 44□	TSD 43
					SN□A 43□	TSS 44
	DCLS-4D	DCL 4D	DCL 4-PL	PIN 0683	CN□X 45□CH	TSC 42
					DN□X 45□CH	TSD 42
					SN□X 45□CHX	TSS 42
	DCLS-4F	DCL 4F	DCL 4-PL	PIN 0683	CN□N 43□	TSC 44
					CN□N 45□	TSC 42
					DN□N 43□	TSD 44
					DN□N 45□	TSD 42
					SN□N 43□	TSS 44
SN□N 45□	TSS 42					

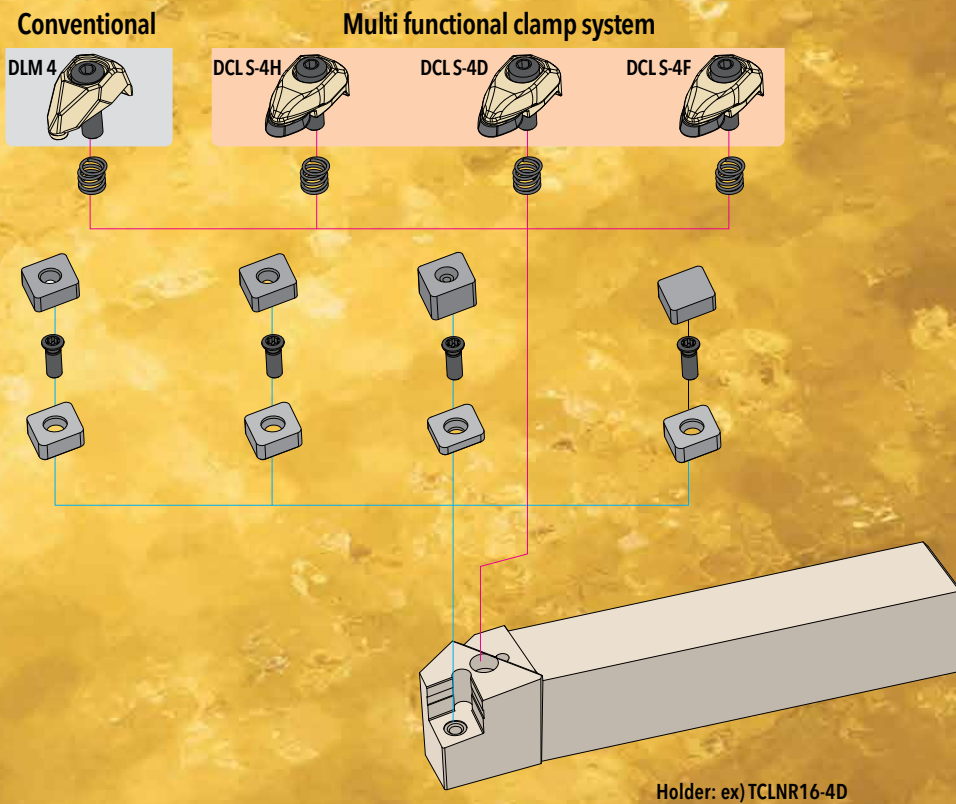



GOLD RUSH GRADES FOR **TOCLAMP** APPLICATIONS

The ingenious solution that takes cutting tool materials to another level

FEATURES

- Improved adhesion and insert chipping resistance
- Stable and extended tool life in continuous and interrupted cutting operations
- Reduced cutting friction and minimized built-up edge
- High quality surface finish on the work piece



GOLD-RUSH GOLD RUSH GRADES IN T-CLAMP APPLICATIONS

TT9100 (CVD) Steel

This new grade features a 20 micron thick, multi-layer CVD coating for maximum wear resistance. It's ideal for high speed turning and grooving in steel applications.

TT9080 (PVD) Steel

In order to improve machining performance over our already successful TT9030 grade, Ingersoll has applied the latest coating technology to the same substrate to form grade TT9080. This grade will improve performance in general turning, grooving, profiling and parting applications on carbon steel, alloy steel and stainless steel. Users can expect wear resistance to improve while still maintaining the same toughness.

TT6300 (CVD) Cast Iron

This new grade features an extra 10 micron thick CVD coating that guarantees excellent tool life, particularly in gray cast iron. It also features a post-coat surface treatment to create a smooth cutting edge that's more resistant to chipping.

TT6080 (PVD) Cast Iron

The latest PVD coating technology has been applied to the K10 substrate that has multi-nano layers of AlTiN, TiAlCrN and TiN. This ensures outstanding performance when machining ductile cast iron. It also is ideal for interrupted cutting of gray cast iron. It also features a post-coat surface treatment to create a smooth cutting edge that's more resistant to chipping.

APPLICATION RANGE IN STEEL MACHINING



APPLICATION RANGE IN CAST IRON MACHINING



GOLD FLEX

QUAD GROOVE LINE

4 CUTTING EDGES WITH CHIP FORMER FOR GROOVING, PARTING AND RECESSING

- 4 cutting-edges designed along with chip-former that provides excellent chip control in most applications.
- 3 contact points with a side torx screw offers highly accurate positioning of the insert.
- Users can release the screw from both side of the holder to index insert. This is another advantage to small machines where there is a small work envelope that restricts insert indexing.
- Gold Rush grade TT9080 is the latest coating technology with multi-nano coating layers. It provides improved surface quality and tool life in a wide variety of materials.

NEW!

- Perpendicular-style holders.



204

FINE GOLD 2013/2014

TQHR/L INTEGRAL SHANK TOOLHOLDERS

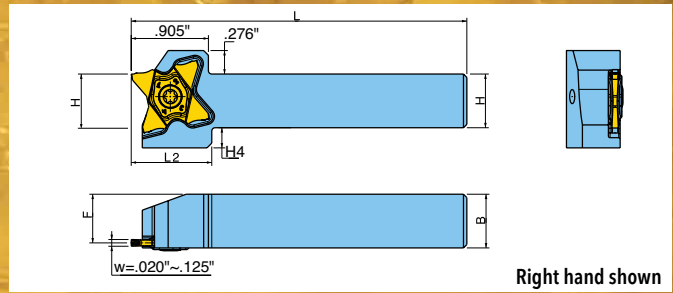

Right hand shown

INCH SHANKS ITEM DESCRIPTION	Dimensions (inch)						Screw	Torx Key	Insert
	H	B	F	L	L2	H4			
TQHL9.5-27	.375	.375	.315	5.0	.945	.374	SM50-125-60	T-2010/5	TQJ27...
TQHL12.7-27	.500	.500	.440	5.0	.945	.287	SM50-125-60	T-2010/5	TQJ27...
TQHL19-27	.750	.750	.690	5.0	.945	.236	SM50-125-60	T-2010/5	TQJ27...
TQHL25.4-27	1.000	1.000	.940	5.5	-	-	SM50-125-60	T-2010/5	TQJ27...
TQHR9.5-27	.375	.375	.315	5.0	.945	.374	SM50-125L60	T-2010/5	TQJ27...
TQHR12.7-27	.500	.500	.440	5.0	.945	.287	SM50-125L60	T-2010/5	TQJ27...
TQHR19-27	.750	.750	.690	5.0	.945	.236	SM50-125L60	T-2010/5	TQJ27...
TQHR25.4-27	1.000	1.000	.940	5.5	-	-	SM50-125L60	T-2010/5	TQJ27...

METRIC SHANKS ITEM DESCRIPTION	Dimensions (mm)						Screw	Torx Key	Insert
	H	B	F	L	L2	H4			
TQHL10-27	10	10	8.5	120	24	9	SM50-125-60	T-2010/5	TQJ27...
TQHL12-27	12	12	10.5	120	24	8	SM50-125-60	T-2010/5	TQJ27...
TQHL16-27	16	16	14.5	120	24	6	SM50-125-60	T-2010/5	TQJ27...
TQHL20-27	20	20	18.5	120	24	2	SM50-125-60	T-2010/5	TQJ27...
TQHL25-27	25	25	23.5	135	-	-	SM50-125-60	T-2010/5	TQJ27...
TQHR10-27	10	10	8.5	120	24	9	SM50-125L60	T-2010/5	TQJ27...
TQHR12-27	12	12	10.5	120	24	8	SM50-125L60	T-2010/5	TQJ27...
TQHR16-27	16	16	14.5	120	24	6	SM50-125L60	T-2010/5	TQJ27...
TQHR20-27	20	20	18.5	120	24	2	SM50-125L60	T-2010/5	TQJ27...
TQHR25-27	25	25	23.5	135	-	-	SM50-125L60	T-2010/5	TQJ27...

TQHL - Left hand holders TQHR - Right hand holders

TQHPR/L INTEGRAL SHANK PERPENDICULAR TOOLHOLDERS

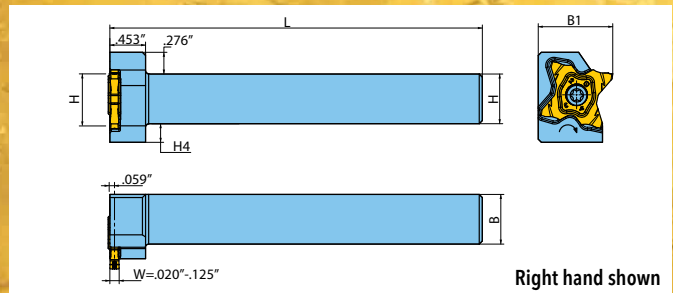

INCH SHANKS ITEM DESCRIPTION	Dimensions (inch)						Screw	Torx Key	Insert
	H	B	B1	L	H4				
TQHPL19-27	.750	.750	1.063	5.0	.118	SM50-125-L60			
TQHPR19-27	.750	.750	1.063	5.0	.118	SM50-125-60	T-2010/5	TQJ27...	
TQHPL25.4-27	1.000	1.000	1.299	5.5	-	SM50-125-L60			
TQHPR25.4-27	1.000	1.000	1.299	5.5	-	SM50-125-60			

METRIC SHANKS ITEM DESCRIPTION	Dimensions (mm)						Screw	Torx Key	Insert
	H	B	B1	L	H4				
TQHPL16-27	16	16	24	120	6	SM50-125-L60			
TQHPR16-27	16	16	24	120	6	SM50-125-60			
TQHPL20-27	20	20	28	120	2	SM50-125-L60	T-2010/5	TQJ27...	
TQHPR20-27	20	20	28	120	2	SM50-125-60			
TQHPL25-27	25	25	33	135	-	SM50-125-L60			
TQHPR25-27	25	25	33	135	-	SM50-125-60			

TQHPL - Left hand holders TQHPR - Right hand holders

TQJ27 FOR PRECISION GROOVING, PARTING AND RECESSING

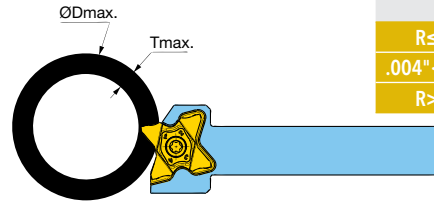
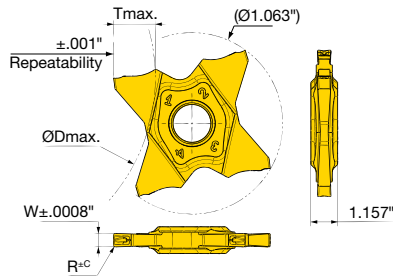

Tolerance	
R	C
R ≤ .004"	.0008"
.004" < R ≤ .016"	.0012"
R > .016"	.0020"

ITEM DESCRIPTION	W (+/- .0008")	R (inch)	T _{max} (inch)	D _{max} (inch) T = Groove Depth									
				T ≤ .118	T ≤ .138	T ≤ .157	T ≤ .177	T ≤ .197	T ≤ .217	T ≤ .236	T ≤ .244	T ≤ .252	
TQJ27-0.50-0.00	.020	-	.039	-	-	-	-	-	-	-	-	-	-
TQJ27-0.50-0.04	.020	.002	.098	-	-	-	-	-	-	-	-	-	-
TQJ27-0.75-0.10	.030	.004	.098	-	-	-	-	-	-	-	-	-	-
TQJ27-0.80-0.00	.031	-	.063	-	-	-	-	-	-	-	-	-	-
TQJ27-1.00-0.06	.039	.002	.138	N.L.	23.62	-	-	-	-	-	-	-	-
TQJ27-1.00-0.10	.039	.004	.138	N.L.	23.62	-	-	-	-	-	-	-	-
TQJ27-1.04-0.00	.041	-	.079	-	-	-	-	-	-	-	-	-	-
TQJ27-1.20-0.00	.047	-	.079	-	-	-	-	-	-	-	-	-	-
TQJ27-1.25-0.10	.049	.004	.138	N.L.	23.62	-	-	-	-	-	-	-	-
TQJ27-1.25-0.20	.049	.008	.138	N.L.	23.62	-	-	-	-	-	-	-	-
TQJ27-1.40-0.00	.055	-	.079	-	-	-	-	-	-	-	-	-	-
TQJ27-1.47-0.00	.058	-	.098	-	-	-	-	-	-	-	-	-	-
TQJ27-1.50-0.10	.059	.004	.197	N.L.	23.62	11.02	7.09	5.12	-	-	-	-	-
TQJ27-1.50-0.20	.059	.008	.197	N.L.	23.62	11.02	7.09	5.12	-	-	-	-	-
TQJ27-1.57-0.15	.062	.006	.118	N.L.	-	-	-	-	-	-	-	-	-
TQJ27-1.57-0.79	.062	.031	.118	N.L.	-	-	-	-	-	-	-	-	-
TQJ27-1.70-0.10	.067	.004	.118	N.L.	-	-	-	-	-	-	-	-	-
TQJ27-1.75-0.10	.069	.004	.118	N.L.	-	-	-	-	-	-	-	-	-
TQJ27-1.75-0.20	.069	.008	.118	N.L.	-	-	-	-	-	-	-	-	-
TQJ27-1.78-0.18	.070	.007	.118	N.L.	-	-	-	-	-	-	-	-	-
TQJ27-1.85-0.20	.073	.008	.118	N.L.	-	-	-	-	-	-	-	-	-

1. N.L. = No Limit
2. Recessing is possible only with 2.39mm (.094") and wider inserts

TQJ27 FOR PRECISION GROOVING, PARTING AND RECESSING

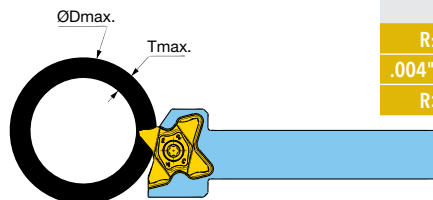
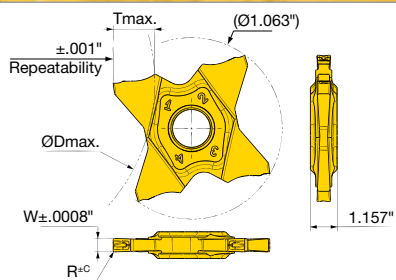

Tolerance	
R	C
R ≤ .004"	.0008"
.004" < R ≤ .016"	.0012"
R > .016"	.0020"

ITEM DESCRIPTION	W (+/- .0008")	R (inch)	Tmax (inch)	Dmax (inch) T = Groove Depth								
				T <= .118	T <= .138	T <= .157	T <= .177	T <= .197	T <= .217	T <= .236	T <= .244	T <= .252
TQJ27-1.96-0.15	.077	.006	.118	N.L.	-	-	-	-	-	-	-	-
TQJ27-2.00-0.10	.079	.004	.252	N.L.	23.62	11.02	7.09	5.12	4.13	2.36	1.97	1.18
TQJ27-2.00-0.20	.079	.008	.252	N.L.	23.62	11.02	7.09	5.12	4.13	2.36	1.97	1.18
TQJ27-2.00-1.00	.079	.039	.118	N.L.	-	-	-	-	-	-	-	-
TQJ27-2.22-0.15	.087	.006	.138	N.L.	23.62	-	-	-	-	-	-	-
TQJ27-2.30-0.20	.091	.008	.138	N.L.	23.62	-	-	-	-	-	-	-
TQJ27-2.39-0.15	.094	.006	.197	N.L.	23.62	11.02	7.09	5.12	-	-	-	-
TQJ27-2.39-1.20	.094	.047	.197	N.L.	23.62	11.02	7.09	5.12	-	-	-	-
TQJ27-2.47-0.20	.097	.008	.197	N.L.	23.62	11.02	7.09	5.12	-	-	-	-
TQJ27-2.50-0.10	.098	.004	.197	N.L.	23.62	11.02	7.09	5.12	-	-	-	-
TQJ27-2.50-0.30	.098	.012	.197	N.L.	23.62	11.02	7.09	5.12	-	-	-	-
TQJ27-2.70-0.10	.106	.004	.244	N.L.	23.62	11.02	7.09	5.31	4.13	3.35	3.07	-
TQJ27-2.87-0.20	.113	.008	.244	N.L.	23.62	11.02	7.09	5.31	4.13	3.35	3.07	-
TQJ27-3.00-0.00	.118	-	.252	N.L.	23.62	11.02	7.09	5.31	4.13	3.35	3.07	2.17
TQJ27-3.00-0.20	.118	.008	.252	N.L.	23.62	11.02	7.09	5.31	4.13	3.35	3.07	2.17
TQJ27-3.00-0.30	.118	.012	.252	N.L.	23.62	11.02	7.09	5.31	4.13	3.35	3.07	2.17
TQJ27-3.00-0.40	.118	.016	.252	N.L.	23.62	11.02	7.09	5.31	4.13	3.35	3.07	2.17
TQJ27-3.00-1.50	.118	.059	.252	N.L.	23.62	11.02	7.09	5.31	4.13	3.35	3.07	2.17
TQJ27-3.15-0.15	.124	.006	.252	N.L.	23.62	11.02	7.09	5.31	4.13	3.35	3.07	2.68
TQJ27-3.18-0.20	.125	.008	.252	N.L.	23.62	11.02	7.09	5.31	4.13	3.35	3.07	2.68

1. N.L. = No Limit
2. Recessing is possible only with 2.39mm (.094") and wider inserts

TQJ27 FOR PARTING AND GROOVING

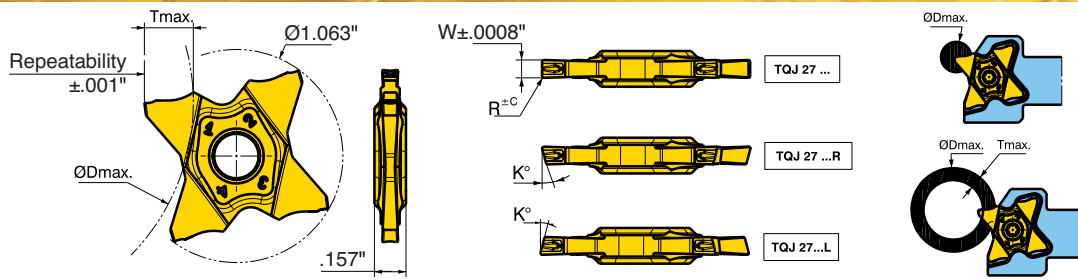

ITEM DESCRIPTION	W (+/- .0008")	R (inch)	K (deg)	Parting to Center		Parting Hollow Bars	
				Dmax (inch)	Tmax (inch)	Dmax (inch)	
TQJ27-0.50-0.04	.020	.002	0	.197	.098	No Limit	
TQJ27-1.00-0.06	.039	.002	0	.276	.138	23.62	
TQJ27-1.50-0.10	.059	.004	0	.472	.197	5.12	
TQJ27-2.00-0.20	.079	.008	0	.512	.252	1.18	
TQJ27-1.00-15R/L	.039	.002	15	.276	.138	23.62	
TQJ27-1.50-6R/L	.059	.002	6	.472	.197	5.12	
TQJ27-1.50-15R/L	.059	.002	15	.472	.197	5.12	
TQJ27-2.00-6R/L	.079	.004	6	.512	.252	1.18	
TQJ27-2.00-15R/L	.079	.004	15	.512	.252	1.18	

MACHINING CONDITION

ISO	Material	Condition	Tensile Strength Rm(N/mm ²)	Hardness HB	Coated	
					TT9080	
P	Non-alloy steel, cast steel, free cutting steel	<0.25 %C	Annealed	420	125	460~820
		>=0.25 %C	Annealed	650	190	430~720
		<0.55 %C	Quenched and tempered	850	250	300~660
			Annealed	750	220	330~720
			>=0.55%C	Quenched and tempered	1000	300
	Low alloy steel and cast steel (less than 5% alloying elements)	Annealed	600	200	300~390	
		Quenched and tempered	930	275	260~560	
			1000	300	230~430	
			1200	350	160~390	
	High alloy steel, cast steel and tool steel.	Annealed	680	200	200~460	
Quenched and tempered		1100	325	160~230		
M	Stainless steel and cast steel	Ferritic/martensitic	680	200	230~560	
		Martensitic	820	240	200~490	
		Austenitic	600	180	300~590	
K	Malleable cast iron	Ferritic/pearlitic		180	390~820	
		Pearlitic		260	330~690	
	Gray cast iron (GG)	Ferritic		160	330~750	
		Pearlitic		250	300~590	
	Cast iron nodular (GGG)	Ferritic		130	620~980	
		Pearlitic		230	390~720	
S	Fe based	Annealed		200	130~230	
		Cured		280	100~160	
	High temp. alloys	Ni or Co based	Annealed		250	100~130
			Cured		350	50~80
		Cast		320	50~100	
	Titanium, Ti alloys	Alpha+beta alloys cured		Rm 400		300~620
				Rm 1050		100~200

Feed Rate

Neutral: .002" ~ .007" ipr

Handed: Reduce 20% feed rate

T•MICRO™

INTERNAL TURNING, PROFILING, GROOVING AND FACE MACHINING OF SMALL DIAMETERS

- Replaceable carbide inserts with thru coolant.
- Internal machining starting at .024" (.6mm).
- TiAlN coating along with sub-micron grade substrate.
- Specifically designed for machining of very small internal diameters.

Machining Condition

	Speed (sfm)	Feed (ipr)		
		Turning	Grooving	Face Grooving
P	35 - 560			
K	35 - 500	.0008" - .0002"	.0004" - .0008"	.0004" - .003"
S	35 - 395			

T•Micro system is a 2 piece design, consisting of a sleeve and replaceable carbide inserts that provide solutions for a wide range of applications including turning, boring, profiling and face grooving.

Inside the new sleeve design is a locating pin to ensure repeatability while allowing users to begin operations without resetting after indexing. Also enables users to replace inserts without removing the sleeve from the tool post.

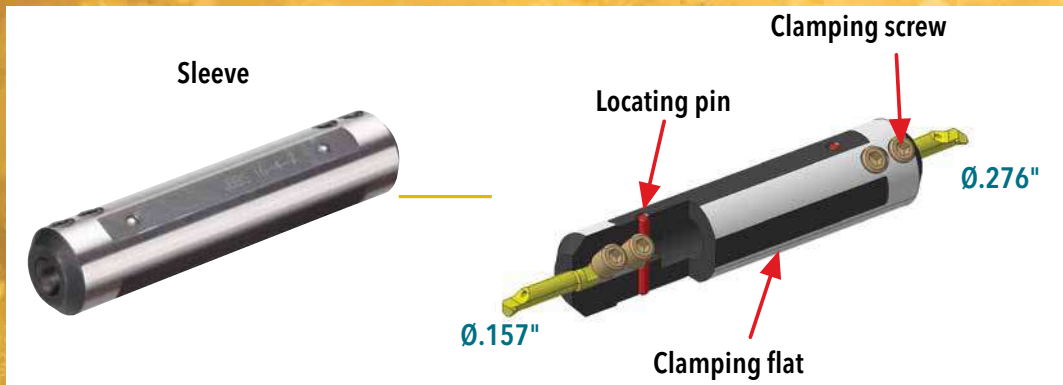



SLEEVES

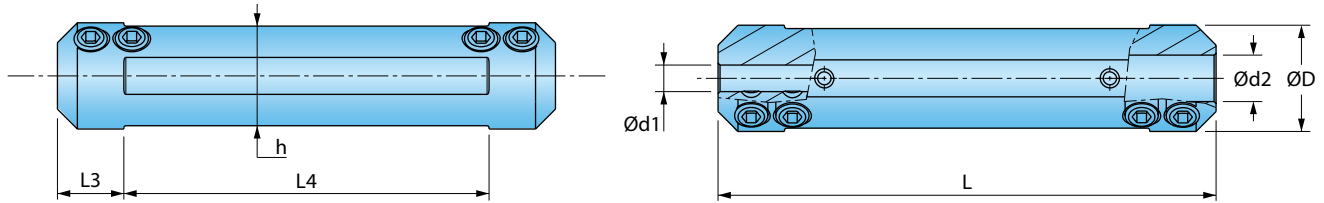

Designation	Dimensions (inches)							Set Screw	Wrench
	ØD	Ød1	Ød2	L	L3	L4	h		
MINSL12-4-4	.472	.157	.157	2.95	.39	2.17	.41	SSM5X0.8X4-MG	L-W2.5
MINSL12.7-4-4	.500	.157	.157	3.00	.39	2.21	.46	SSM5X0.8X4-MG	L-W2.5
MINSL14-4-4	.551	.157	.157	2.95	.39	2.17	.47	SSM5X0.8X6-MG	L-W2.5
MINSL15.9-4-7	.625	.157	.276	3.00	.39	2.21	.55	SSM5X0.8X6-MG	L-W2.5
MINSL16-4-7	.630	.157	.276	2.95	.39	2.17	.59	SSM5X0.8X6-MG	L-W2.5
MINSL19-4-7	.750	.157	.276	3.50	.39	2.72	.68	SSM5X0.8X6-MG	L-W2.5
MINSL20-4-7	.787	.157	.276	3.54	.39	2.76	.71	SSM5X0.8X6-MG	L-W2.5
MINSL22-4-7	.866	.157	.276	3.54	.39	2.76	.79	SSM5X0.8X6-MG	L-W2.5
MINSL25-4-7	.984	.157	.276	3.94	.39	3.15	.91	SSM5X0.8X6-MG	L-W2.5
MINSL25.4-4-7	1.000	.157	.276	3.54	.39	2.76	.92	SSM5X0.8X6-MG	L-W2.5

COOLANT FITTING

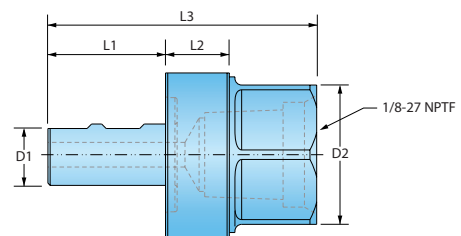
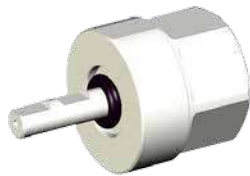

Designation	Dimensions				
	D1	L1	L2	L3	D2
NEW! PF-MIN4	.156 (3.96mm)	.525 (13.34mm)	.285 (7.24mm)	1.200 (30.48mm)	.740 (18.80mm)
NEW! PF-MIN7	.274 (6.96mm)	.525 (13.34mm)	.285 (7.24mm)	1.200 (30.48mm)	.740 (18.80mm)

MINT - MINI CARBIDE BARS FOR INTERNAL TURNING AND CHAMFERING

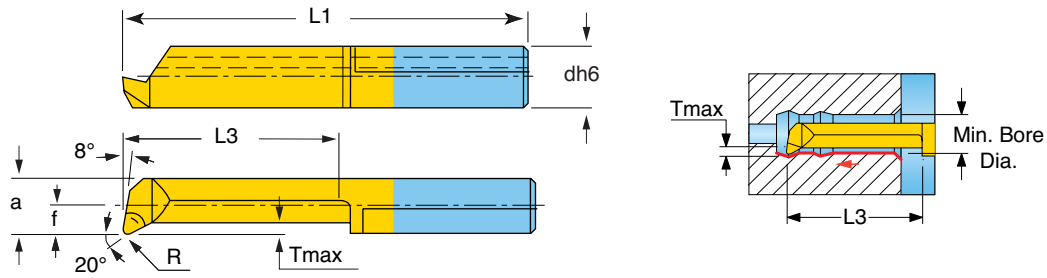

Designation	dh6	f	a	Dimensions (inches)			R±0.002	Tmax	Dmin	R/L	Grade
				L1	L3						
*MINTRO4-020004D006	.157	-	.020	.728	.14	.002	.003	.024	R	TT9030	
*MINTRO4-030004D006	.157	-	.020	.768	.18	.002	.003	.024	R	TT9030	
MINTRO4-045005D010	.157	-	.035	.827	.24	.002	.004	.039	R	TT9030	
MINTRO4-065005D010	.157	-	.035	.906	.31	.002	.004	.039	R	TT9030	
MINTRO4-040005D020	.157	-	.067	.807	.22	.002	.004	.079	R	TT9030	
MINTRO4-090005D020	.157	-	.067	1.004	.41	.002	.004	.079	R	TT9030	
MINTRO4-140005D020	.157	-	.067	1.201	.61	.002	.004	.079	R	TT9030	
MINTL04-090010D028	.157	.024	.102	1.004	.41	.004	.008	.110	L	TT9030	
MINTRO4-090010D028	.157	.024	.102	1.004	.41	.004	.008	.110	R	TT9030	
MINTL04-150010D028	.157	.024	.102	1.240	.65	.004	.008	.110	L	TT9030	
MINTRO4-150010D028	.157	.024	.102	1.240	.65	.004	.008	.110	R	TT9030	
MINTL04-190010D028	.157	.024	.102	1.398	.81	.004	.008	.110	L	TT9030	
MINTRO4-190010D028	.157	.024	.102	1.339	.81	.004	.008	.110	R	TT9030	
MINTL04-090010D040	.157	.059	.138	1.004	.41	.004	.012	.157	L	TT9030	
MINTRO4-090010D040	.157	.059	.138	1.004	.41	.004	.012	.157	R	TT9030	
MINTL04-150010D040	.157	.059	.138	1.240	.65	.004	.012	.157	L	TT9030	
MINTRO4-150010D040	.157	.059	.138	1.240	.65	.004	.012	.157	R	TT9030	
MINTL04-190010D040	.157	.059	.138	1.398	.81	.004	.012	.157	L	TT9030	
MINTRO4-190010D040	.157	.059	.138	1.398	.81	.004	.012	.157	R	TT9030	
MINTRO4-230010D040	.157	.059	.138	1.555	.96	.004	.012	.157	R	TT9030	
MINTRO4-270010D040	.157	.059	.138	1.713	1.12	.004	.012	.157	R	TT9030	

*Max DOC = .0004"~.0012", Max feed = .0004" ipr

MINT - MINI CARBIDE BARS FOR INTERNAL TURNING AND CHAMFERING

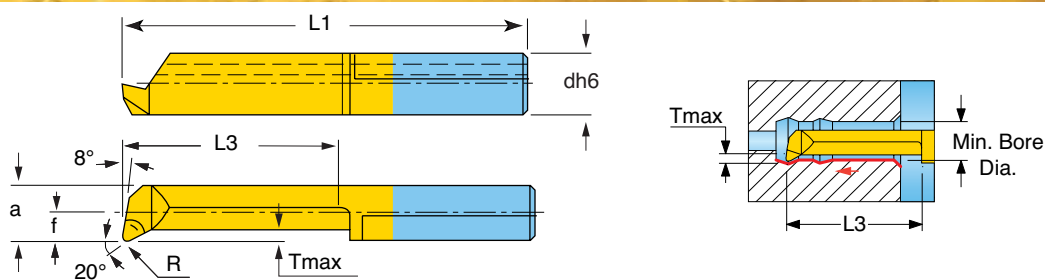

Designation	dh6	f	a	Dimensions (inches)			R±0.002	Tmax	Dmin	R/L	Grade
				L1	L3						
MINTL07-090015D050	.276	.075	.173	.984	.35	.006	.020	.197	L	TT9030	
MINTR07-090015D050	.276	.075	.173	.984	.35	.006	.020	.197	R	TT9030	
MINTL07-140015D050	.276	.075	.173	1.181	.55	.006	.020	.197	L	TT9030	
MINTR07-140015D050	.276	.075	.173	1.181	.55	.006	.020	.197	R	TT9030	
MINTL07-190015D050	.276	.075	.173	1.378	.75	.006	.020	.197	L	TT9030	
MINTR07-190015D050	.276	.075	.173	1.378	.75	.006	.020	.197	R	TT9030	
MINTL07-240015D050	.276	.075	.173	1.575	.94	.006	.020	.197	L	TT9030	
MINTR07-240015D050	.276	.075	.173	1.575	.94	.006	.020	.197	R	TT9030	
MINTL07-290015D050	.276	.075	.173	1.772	1.14	.006	.020	.197	L	TT9030	
MINTR07-290015D050	.276	.075	.173	1.772	1.14	.006	.020	.197	R	TT9030	
MINTR07-340015D050	.276	.075	.173	1.969	1.34	.006	.020	.197	R	TT9030	
MINTL07-140015D060	.276	.091	.209	1.181	.55	.006	.020	.236	L	TT9030	
MINTR07-140015D060	.276	.091	.209	1.181	.55	.006	.020	.236	R	TT9030	
MINTL07-210015D060	.276	.091	.209	1.457	.83	.006	.020	.236	L	TT9030	
MINTR07-210015D060	.276	.091	.209	1.457	.83	.006	.020	.236	R	TT9030	
MINTL07-240015D060	.276	.091	.209	1.575	.94	.006	.020	.236	L	TT9030	
MINTR07-240015D060	.276	.091	.209	1.575	.94	.006	.020	.236	R	TT9030	
MINTL07-290015D060	.276	.091	.209	1.772	1.14	.006	.020	.236	L	TT9030	
MINTR07-290015D060	.276	.091	.209	1.772	1.14	.006	.020	.236	R	TT9030	
MINTR07-340015D060	.276	.091	.209	1.969	1.34	.006	.020	.236	R	TT9030	
MINTR07-410015D060	.276	.091	.209	2.244	1.61	.006	.020	.236	R	TT9030	
MINTL07-190015D068	.276	.110	.248	1.378	.75	.006	.024	.268	L	TT9030	
MINTR07-190015D068	.276	.110	.248	1.378	.75	.006	.024	.268	R	TT9030	
MINTR07-240015D068	.276	.110	.248	1.575	.94	.006	.024	.268	R	TT9030	
MINTL07-290015D068	.276	.110	.248	1.772	1.14	.006	.024	.268	L	TT9030	
MINTR07-290015D068	.276	.110	.248	1.772	1.14	.006	.024	.268	R	TT9030	
MINTL07-340015D070	.276	.110	.248	1.969	1.34	.006	.024	.276	L	TT9030	
MINTR07-340015D070	.276	.110	.248	1.969	1.34	.006	.024	.276	R	TT9030	
MINTR07-390015D070	.276	.110	.248	2.165	1.54	.006	.024	.276	R	TT9030	
MINTR07-440015D070	.276	.110	.248	2.362	1.73	.006	.024	.276	R	TT9030	
MINTR07-490015D070	.276	.110	.248	2.559	1.93	.006	.024	.276	R	TT9030	

MINP - MINI CARBIDE BARS FOR INTERNAL TURNING AND PROFILING

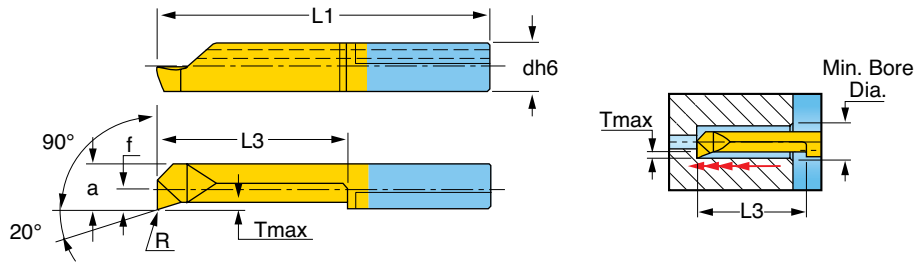

Designation	dh6	f	a	Dimensions (inches)			R±0.002	Tmax	Dmin	R/L	Grade
				L1	L3						
MINPR04-090010D028	.157	.024	.102	1.004	.413	.004	.008	.110	R	TT9030	
MINPR04-150010D028	.157	.024	.102	1.240	.650	.004	.008	.110	R	TT9030	
MINPR04-090010D040	.157	.059	.138	1.004	.413	.004	.012	.157	R	TT9030	
MINPR04-150010D040	.157	.059	.138	1.240	.650	.004	.012	.157	R	TT9030	
MINPR07-140015D050	.276	.035	.173	1.181	.591	.006	.020	.197	R	TT9030	
MINPR07-190015D050	.276	.035	.173	1.378	.787	.006	.020	.197	R	TT9030	

MINC - MINI CARBIDE BARS FOR INTERNAL TURNING AND 45° CHAMFERING

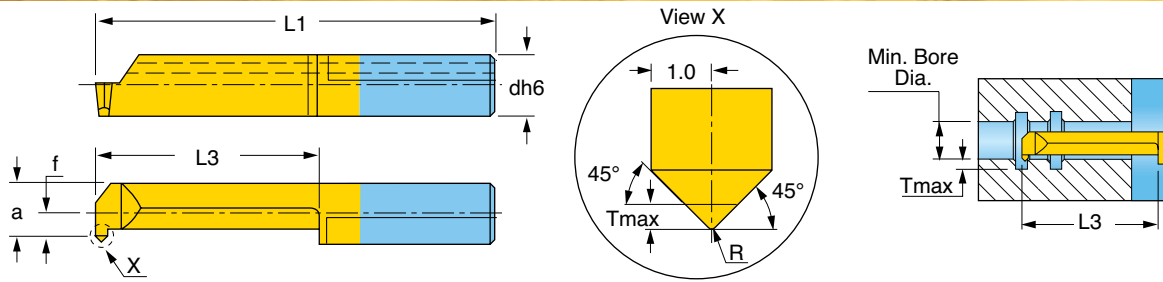

Designation	dh6	R±0.0016	f	a	Dimensions (inches)		Tmax	Dmin	R/L	Grade
					L1	L3				
MINCR07-140020D050	.276	.008	.035	.173	1.181	.551	.028	.197	R	TT9030
MINCR07-190020D050	.276	.008	.035	.173	1.378	.787	.028	.197	R	TT9030
MINCR07-190020D068	.276	.008	.110	.248	1.378	.787	.028	.268	R	TT9030

MING - MINI CARBIDE BARS FOR GROOVING AND TURNING

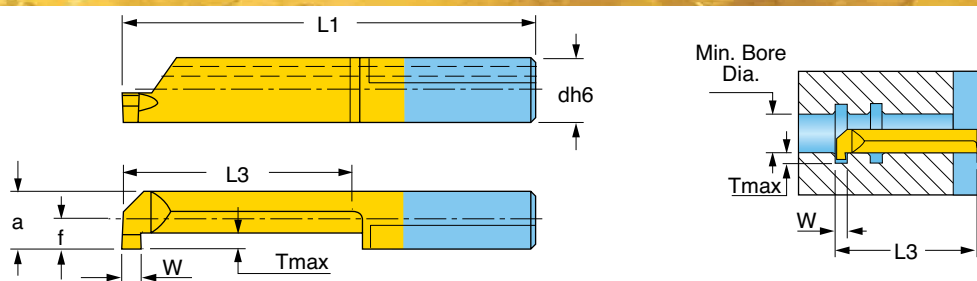

Designation	Dimensions (inches)									
	dh6	W±0.05	f	a	L1	L3	Tmax	Dmin	R/L	Grade
MINGR04-050050-D20	.157	.020	.008	.071	.827	.236	.016	.079	R	TT9030
MINGR04-100050-D20	.157	.020	.008	.071	1.024	.433	.016	.079	R	TT9030
MINGR04-050070-D30	.157	.028	.028	.106	.827	.236	.024	.118	R	TT9030
MINGR04-100070-D30	.157	.028	.028	.106	1.024	.433	.024	.118	R	TT9030
MINGR04-090100-D40	.157	.039	.059	.138	1.004	.413	.031	.157	R	TT9030
MINGR04-150100-D40	.157	.039	.059	.138	1.240	.650	.031	.157	R	TT9030
MINGR07-090100-D50	.276	.039	.035	.173	.984	.394	.039	.197	R	TT9030
MINGR07-140100-D50	.276	.039	.035	.173	1.181	.591	.039	.197	R	TT9030
MINGR07-090150-D50	.276	.059	.035	.173	.984	.394	.039	.197	R	TT9030
MINGR07-140150-D50	.276	.059	.035	.173	1.181	.591	.039	.197	R	TT9030
MINGR07-090200-D50	.276	.079	.035	.173	.984	.394	.039	.197	R	TT9030
MINGR07-190200-D50	.276	.079	.035	.173	1.378	.787	.039	.197	R	TT9030
MINGR07-090100D060	.276	.039	.071	.209	.984	.394	.071	.236	R	TT9030
MINGL07-090100D060	.276	.039	.071	.209	.984	.394	.071	.236	L	TT9030
MINGR07-140100D060	.276	.039	.071	.209	1.181	.591	.071	.236	R	TT9030
MINGR07-210100D060	.276	.039	.071	.209	1.457	.866	.071	.236	R	TT9030
MINGR07-290100D060	.276	.039	.071	.209	1.772	1.181	.071	.236	R	TT9030
MINGR07-090150D060	.276	.059	.071	.209	.984	.394	.071	.236	R	TT9030
MINGL07-090150D060	.276	.059	.071	.209	.984	.394	.071	.236	L	TT9030
MINGR07-140150D060	.276	.059	.071	.209	1.181	.591	.071	.236	R	TT9030
MINGR07-210150D060	.276	.059	.071	.209	1.457	.866	.071	.236	R	TT9030
MINGR07-240150D060	.276	.059	.071	.209	1.575	.984	.071	.236	R	TT9030
MINGR07-290150D060	.276	.059	.071	.209	1.772	1.181	.071	.236	R	TT9030
MINGR07-090200D060	.276	.079	.071	.209	.984	.394	.071	.236	R	TT9030
MINGR07-140200D060	.276	.079	.071	.209	1.181	.591	.071	.236	R	TT9030
MINGR07-210200D060	.276	.079	.071	.209	1.457	.866	.071	.236	R	TT9030
MINGR07-240200D060	.276	.079	.071	.209	1.575	.984	.071	.236	R	TT9030
MINGR07-290200D060	.276	.079	.071	.209	1.772	1.181	.071	.236	R	TT9030
MINGR07-090100D068	.276	.039	.106	.244	.984	.394	.098	.268	R	TT9030
MINGR07-140100D068	.276	.039	.106	.244	1.181	.591	.098	.268	R	TT9030
MINGR07-210100D068	.276	.039	.106	.244	1.457	.866	.098	.268	R	TT9030
MINGR07-090150D068	.276	.059	.106	.244	.984	.394	.098	.268	R	TT9030
MINGR07-140150D068	.276	.059	.106	.244	1.181	.591	.098	.268	R	TT9030
MINGR07-210150D068	.276	.059	.106	.244	1.457	.866	.098	.268	R	TT9030
MINGR07-290150D068	.276	.059	.106	.244	1.772	1.181	.098	.268	R	TT9030
MINGR07-090200D068	.276	.079	.106	.244	.984	.394	.098	.268	R	TT9030
MINGR07-140200D068	.276	.079	.106	.244	1.181	.591	.098	.268	R	TT9030
MINGL07-140200D068	.276	.079	.106	.244	1.181	.591	.098	.268	L	TT9030
MINGR07-210200D068	.276	.079	.106	.244	1.457	.866	.098	.268	R	TT9030
MINGR07-290200D068	.276	.079	.106	.244	1.772	1.142	.098	.268	R	TT9030

MINF - MINI CARBIDE BARS FOR DEEP FACE GROOVING

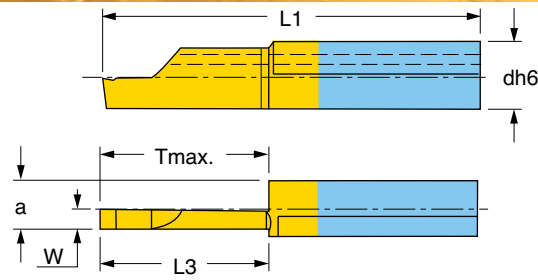

Designation	Dimensions (inches)								Grade
	dh6	W	a	L3	L1	Tmax	Dmin	R/L	
MINFR07-200250D150	.276	.098	.232	.827	1.417	.787	.591	R	TT9030
MINFR07-200300D150	.276	.118	.232	.827	1.417	.787	.591	R	TT9030
MINFR07-300300D150	.276	.118	.232	1.220	1.811	1.181	.591	R	TT9030

MINF - MINI CARBIDE BARS FOR FACE GROOVING

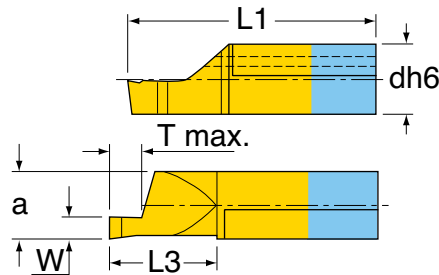

Designation	Dimensions (inches)								Grade
	dh6	W	a	L3	L1	Tmax	Dmin	R/L	
MINFR07-110100D060	.276	.039	.205	.433	1.024	.059	.236	R	TT9030
MINFR07-110100D080	.276	.039	.232	.472	1.063	.059	.315	R	TT9030
MINFR07-110150D060	.276	.059	.205	.433	1.024	.079	.236	R	TT9030
MINFR07-110200D060	.276	.079	.232	.472	1.063	.118	.315	R	TT9030
MINFR07-200200D080	.276	.079	.205	.787	1.378	.118	.315	R	TT9030
MINFL07-210150D080	.276	.059	.232	.827	1.417	.098	.315	L	TT9030
MINFR07-110150D080	.276	.059	.232	.472	1.063	.098	.315	R	TT9030
MINFR07-210150D080	.276	.059	.232	.866	1.417	.098	.315	R	TT9030
MINFL07-300200D080	.276	.079	.232	1.220	1.811	.118	.315	L	TT9030
MINFR07-110200D080	.276	.079	.232	.472	1.063	.118	.315	R	TT9030
MINFR07-210200D080	.276	.079	.232	.866	1.417	.118	.315	R	TT9030
MINFR07-110250D080	.276	.098	.232	.472	1.063	.138	.315	R	TT9030
MINFR07-210250D080	.276	.098	.232	.866	1.417	.138	.315	R	TT9030
MINFR07-110300D080	.276	.118	.232	.472	1.063	.138	.315	R	TT9030
MINFR07-210300D080	.276	.118	.232	.866	1.417	.138	.315	R	TT9030
MINFR07-300300D080	.276	.118	.232	1.220	1.811	.138	.315	R	TT9030

MINA - MINI CARBIDE BARS FOR SHAFT GROOVING

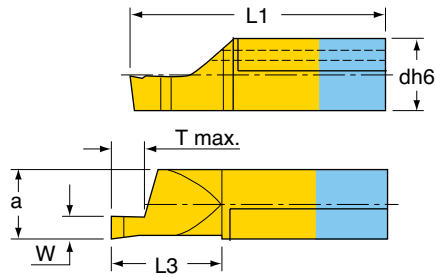

Designation	Dimensions (inches)									
	dh6	W	a	L3	L1	Tmax	Dmin	R/L	Grade	
MINAR07-200200D060	.276	.079	.205	.827	1.417	.157	.236	R	TT9030	

MINR - MINI CARBIDE BARS, FULL RADIUS FOR INTERNAL BORING AND PROFILING

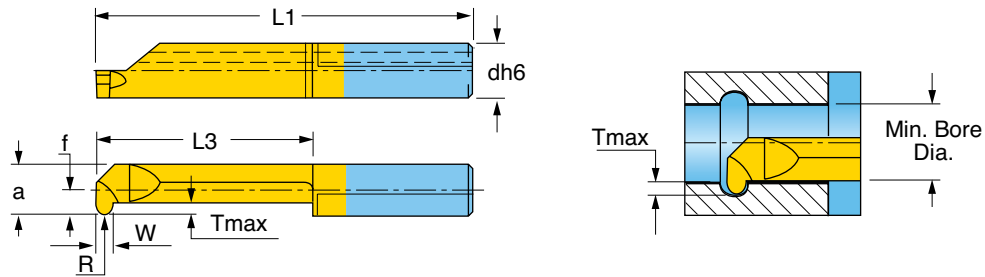

Designation	Dimensions (inches)										
	dh6	W±0.002	f	a	R	L1	L3	Tmax	Dmin	R/L	Grade
MINRR07-190050D050	.276	.039	.035	.173	.020	1.378	.787	.039	.197	R	TT9030
MINRR07-240050D060	.276	.039	.071	.209	.020	1.575	.984	.071	.236	R	TT9030
MINRR07-290050D068	.276	.039	.110	.248	.020	1.772	1.181	.098	.268	R	TT9030

MINN - MINI CARBIDE BARS FOR 60° PROFILE INTERNAL THREAD TURNING

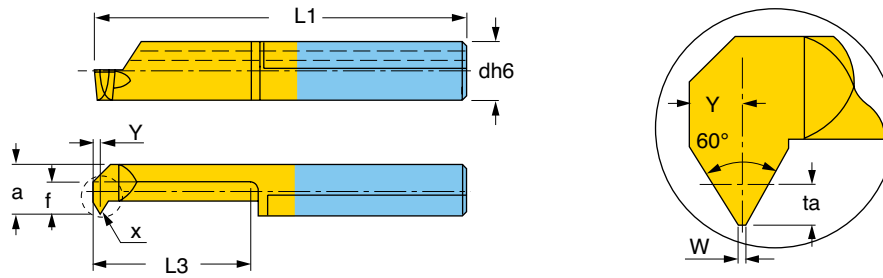

Designation	dh6	MAX Pitch		ta	W+.000 -.001	Dimensions (inches)					Dmin	Grade
		TPI	mm			Y	f	a	L3	L1		
MINNR04-140050D040	.157	48	.50	.012	.002	.014	.059	.138	.591	1.181	.157	TT9030
MINNR07-140050D050	.276	48	.50	.012	.002	.014	.035	.173	.591	1.181	.197	TT9030
MINNR07-140050D075	.276	32	.75	.016	.035	.018	.035	.173	.591	1.181	.197	TT9030
MINNR07-140100D048	.276	24	1.00	.024	.005	.022	.035	.173	.591	1.181	.189	TT9030
MINNR07-140100D060	.276	24	1.00	.024	.005	.022	.071	.209	.591	1.181	.236	TT9030
MINNR07-140125D060	.276	20	1.25	.028	.006	.026	.071	.209	.591	1.181	.236	TT9030
MINNR07-140150D060	.276	16	1.50	.031	.007	.030	.071	.209	.591	1.181	.236	TT9030
MINNR07-140150D070	.276	16	1.50	.031	.007	.030	.110	.248	.591	1.181	.276	TT9030

MINB - MINI CARBIDE BARS FOR INTERNAL BACK TURNING

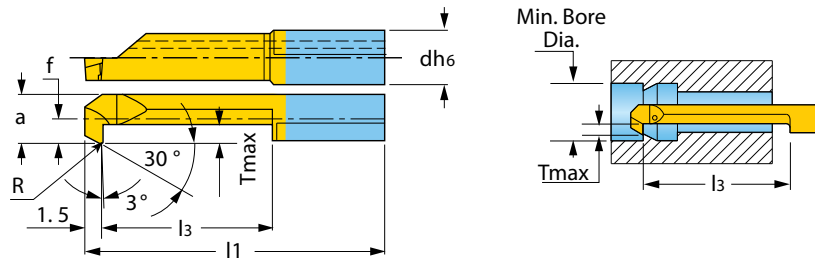

Designation	Dimensions (inches)									
	dh6	f	a	L1	L3	R±0.002	Tmax	Dmin	R/L	Grade
MINBR04-140010D030	.157	.024	.102	1.181	.591	.008	.020	.118	R	TT9030
MINBR04-190010D030	.157	.024	.102	1.378	.787	.008	.020	.118	R	TT9030
MINBR04-140015D040	.157	.059	.138	1.181	.591	.006	.031	.157	R	TT9030
MINBR04-240015D040	.157	.059	.138	1.575	.984	.006	.031	.157	R	TT9030
MINBR07-190020D050	.276	.035	.173	1.378	.787	.008	.039	.197	R	TT9030
MINBR07-290020D050	.276	.035	.173	1.772	1.181	.008	.039	.197	R	TT9030
MINBR07-190020D060	.276	.071	.209	1.378	.787	.008	.071	.236	R	TT9030
MINBR07-290020D060	.276	.071	.209	1.772	1.181	.008	.071	.236	R	TT9030
MINBR07-190020D070	.276	.110	.248	1.378	.787	.008	.098	.276	R	TT9030
MINBR07-290020D070	.276	.110	.248	1.772	1.181	.008	.098	.276	R	TT9030

TOCLAMP

FOR SMALL ID AND OD TURNING AND GROOVING

- Economical double-ended insert
- Internal bars are coolant-through
- NEW!** • Holder styles for shallow grooves and external machining
- Various application range
 - TDIP: ground insert for precision grooving and ID turning
 - TDIM: pressed insert with molded chipbreaker for optimal chip control
- Internal machining from Dmin .472"



222

FINE GOLD

TTSIR/L - INTERNAL GROOVING AND TURNING ON SMALL DIAMETERS

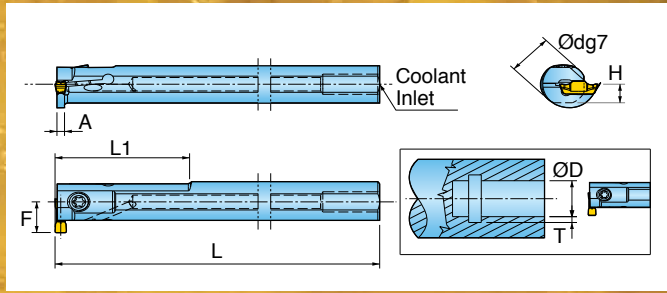

Designation	Insert Seat Size	Ød	Dimensions (inch)					Coolant Inlet	Screw	Wrench		
			L	L1	F	H	A					
TTSIR/L 9.5-12.5-2	2	.375	5.0	.984	.295	.167	.063	.094	.492	Ø.138	SE02-82	T 15
TTSIR/L 12.7-14-2	2	.500	5.0	1.378	.358	.230	.063	.102	.551	Ø.236	SE02-82	T 15
TTSIR/L 15.9-12.5-2	2	.625	6.0	.787	.413	.291	.063	.094	.492	Ø.315	SE02-82	T 15
TTSIR/L 15.9-14-2	2	.625	6.0	.984	.433	.291	.063	.102	.551	Ø.315	SE02-82	T 15
TTSIR/L 15.9-16-2	2	.625	6.0	1.575	.433	.291	.063	.118	.630	Ø.315	SR16-212	T 20
TTSIR/L 12.7-14-3	3	.375	5.0	1.378	.358	.230	.079	.102	.551	Ø.236	SE02-82	T 15
TTSIR/L 15.9-12.5-3	3	.625	6.0	.787	.413	.291	.079	.094	.492	Ø.315	SE02-82	T 15
TTSIR/L 15.9-14-3	3	.625	6.0	.984	.433	.291	.079	.102	.551	Ø.315	SE02-82	T 15
TTSIR/L 15.9-16-3	3	.625	6.0	1.575	.433	.291	.079	.118	.630	Ø.315	SR16-212	T 20
TTSIR/L 19-20-3	3	.750	6.0	1.575	.551	.335	.079	.157	.787	PL075	SR16-212	T 20

TTSIL: Left-hand holder TTSIR: Right-hand holder

NEW! TGSIR/L - INTERNAL SHALLOW GROOVING AND TURNING ON SMALL DIAMETERS

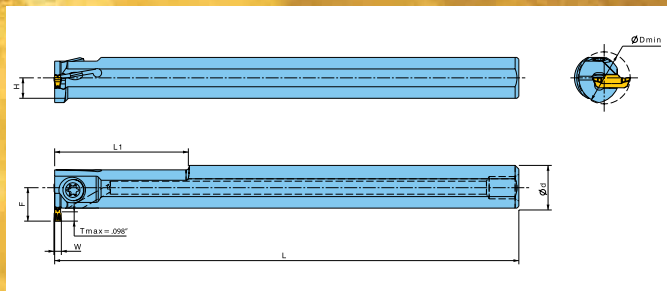

Designation	Insert Seat Size	Ød	Dimensions (inch)					Coolant Inlet	W	Screw	Wrench
			L	L1	F	H	Tmax				
TGSIR/L 9.5-13-2	2	.375	5.0	.984	.295	.167	2.50	.492	Ø.138		
TGSIR/L 12.7-14-2	2	.500	5.0	1.378	.354	.230	2.50	.551	Ø.236		
TGSIR/L 15.9-13-2	2	.625	6.0	.787	.417	.291	2.50	.512	Ø.315	< .080	SE02-82 T 15
TGSIR/L 15.9-14-2	2	.625	6.0	.984	.429	.291	2.50	.551	Ø.315		
TGSIR/L 15.9-16-2	2	.625	6.0	1.575	.413	.291	2.50	.630	Ø.315		

TGSIL: Left-hand holder TGSIR: Right-hand holder

NEW! **TTSER/L - EXTERNAL TURNING AND GROOVING**

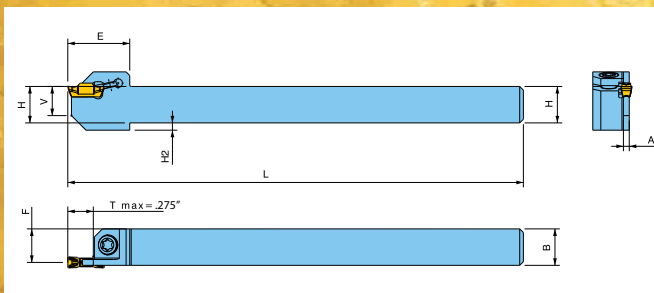

Designation	Insert Seat Size	Dimensions (inch)							Screw	Wrench
		H	B	L	F	E	A	H1		
TTSER/L 9.5-2T7	2	.375	.375	5.0	.343	.669	.063	.079	SM40-097-60	T 15
TTSER/L 12.7-2T7	2	.500	.500	5.0	.469	.669	.063	-		
TTSER/L 15.9-2T7	2	.625	.625	5.0	.598	.787	.063	-		
TTSER/L 19-2T7	2	.750	.750	5.0	.717	.787	.063	-		
TTSER/L 25.4-2T7	2	1.000	1.000	5.0	.969	.787	.063	-		
TTSER/L 9.5-3T7	3	.375	.375	5.0	.327	.669	.094	.079		
TTSER/L 12.7-3T7	3	.500	.500	5.0	.453	.669	.094	-		
TTSER/L 15.9-3T7	3	.625	.625	5.0	.579	.787	.094	-		
TTSER/L 19-3T7	3	.750	.750	5.0	.701	.787	.094	-		
TTSER/L 25.4-3T7	3	1.000	1.000	5.0	.953	.787	.094	-		

TTSEL: Left-hand holder TTSER: Right-hand holder

NEW! **TGSFR/L - SHALLOW EXTERNAL TURNING AND GROOVING**

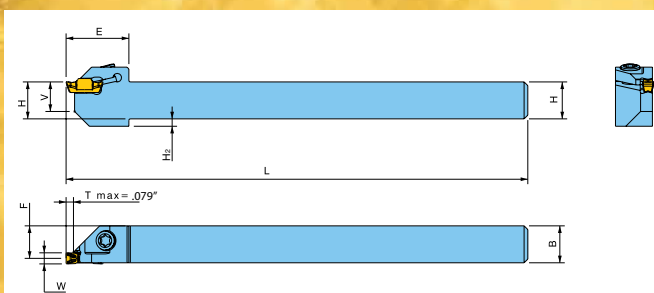

Designation	Insert Seat Size	Dimensions (inch)							Screw	Wrench
		H	B	L	F	E	H1	W		
TGSFR/L 9.5-3T2	2, 3	.375	.375	5.0	.327	.669	.079	< .125	SM40-097-60	T 15
TGSFR/L 12.7-3T2	2, 3	.500	.500	5.0	.453	.669	-			
TGSFR/L 15.9-3T2	2, 3	.625	.625	5.0	.579	.787	-			

TGSFL: Left-hand holder TGSFR: Right-hand holder

TDIM - PRESSED INSERTS FOR INTERNAL TURNING AND GROOVING

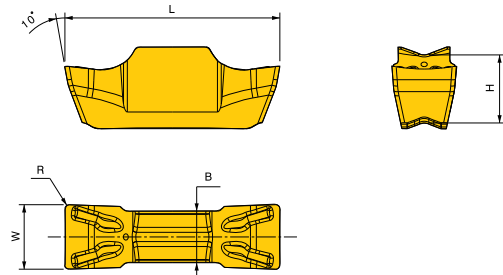
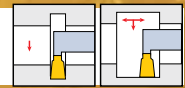

Designation	Insert Seat Size	W±0.002	Dimensions (inch)				Grade
			R	B	L	H	
TDIM 2E-0.15	2	.079	.006	.063	.394	.126	TT9080
TDIM 3E-0.2	3	.118	.008	.094	.394	.126	TT9080

TDIP - PRECISION INSERTS FOR INTERNAL TURNING AND GROOVING

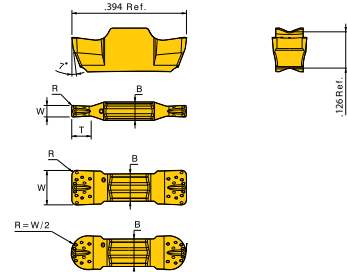
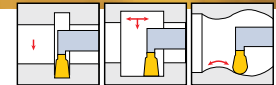

Designation	Insert Seat Size	W±0.0008	Dimensions (inch)				Grade
			R	B	T		
TDIP 1.00-0.10*	2	.039	.004	.063	.063	TT9080	
TDIP 1.00-0.50*	2	.039	.020	.063	.063	TT9080	
TDIP 1.20-0.00*	2	.047	.000	.063	.071	TT9080	
TDIP 1.40-0.00*	2	.055	.000	.063	.079	TT9080	
TDIP 1.50-0.10*	2	.059	.004	.063	.079	TT9080	
TDIP 2.00E-0.10	2	.079	.004	.063	-	TT9080	
TDIP 2.00E-0.20	2	.079	.008	.063	-	TT9080	
TDIP 2.00E-1.00	2	.079	.039	.063	-	TT9080	
TDIP 2.15E-0.15	2	.085	.006	.063	-	TT9080	
TDIP 2.50E-0.20	3	.098	.008	.094	-	TT9080	
TDIP 3.00E-0.20	3	.118	.008	.094	-	TT9080	
TDIP 3.00E-1.50	3	.118	.059	.094	-	TT9080	

*Use holders TGSIR/L, TGSFR/L. (Only for grooving)

TT5080 Grade FOR LATHE THREADING APPLICATIONS

- Grade TT5080 features a very hard submicron grain substrate with PVD-AlTiN/TiN coating and special post-coat treatment.
- Improved flaking and chipping resistance in all materials.
- Excellent for stainless steels and high-temperature alloys.



Regular-Type

M-Type

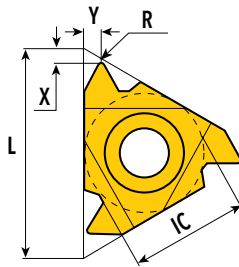
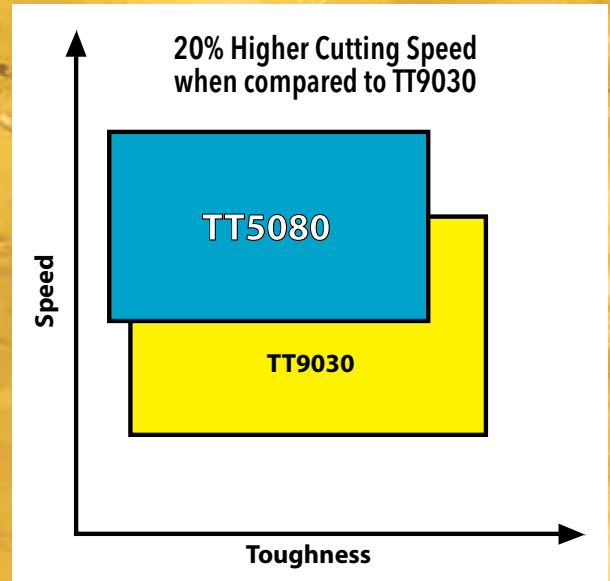

Application:
General Industry

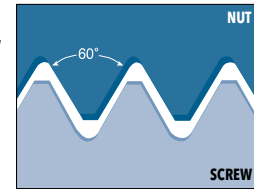

PARTIAL PROFILE 60°

Designation	Thread Type	Hand	Insert Type	IC (inch)	Pitch TPI	Pitch mm	L (inch)	R (inch)	X (inch)	Y (inch)	Grade		
08IRMA60	INTERNAL	RIGHT	M TYPE	0.188	16-48	.5-1.5	0.315	0.002	0.024	0.028	TT5080		
11IRMA60			M TYPE	0.250	16-48	.5-1.5	0.433	0.002	0.031	0.035			
16IRMA60			M TYPE	0.375	16-48	.5-1.5	0.630	0.002	0.031	0.035			
16IRMG60			M TYPE	0.375	8-14	1.75-3.0	0.630	0.005	0.047	0.067			
16IRAG60			REGULAR	0.375	8-48	.5-3.0	0.630	0.002	0.047	0.067			
16IRMAG60			M TYPE	0.375	8-48	.5-3.0	0.630	0.002	0.047	0.067			
22IRMN60			M TYPE	0.500	5-7	3.5-5.0	0.866	0.007	0.067	0.098			
16ERMA60			EXTERNAL	RIGHT	M TYPE	0.375	16-48	.5-1.5	0.630	0.002		0.031	0.035
16ERMG60					M TYPE	0.375	8-14	1.75-3.0	0.630	0.005		0.047	0.067
16ERAG60					REGULAR	0.375	8-48	.5-3.0	0.630	0.002		0.047	0.067
16ERMAG60					M TYPE	0.375	8-48	.5-3.0	0.630	0.002		0.047	0.067
22ERMN60					M TYPE	0.500	5-7	3.5-5.0	0.866	0.007		0.067	0.098

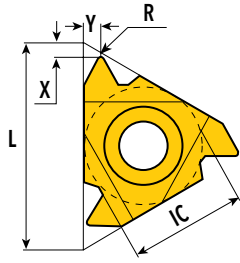

Application:
General Industry

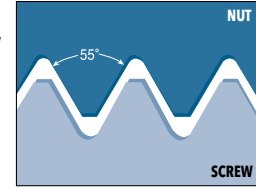

PARTIAL PROFILE 55°

Designation	Thread Type	Hand	Insert Type	IC (inch)	Pitch TPI	Pitch mm	L (inch)	R (inch)	X (inch)	Y (inch)	Grade
16IRMAG55	INTERNAL	RIGHT	M TYPE	0.375	8-48	.5-3.0	0.630	0.002	0.047	0.067	TT5080
16ERMAG55	EXTERNAL										

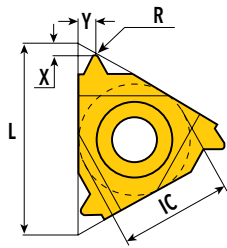

Application:
General Industry

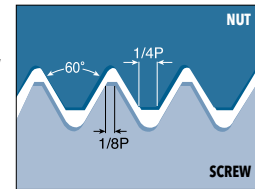

ISO FULL PROFILE (DIN13 12-1986 CLASS 6G/6H)

Designation	Thread Type	Hand	Insert Type	IC (inch)	Pitch mm	L (inch)	R (inch)	X (inch)	Y (inch)	Grade
11IR1.50ISO	INTERNAL	RIGHT	REGULAR	0.250	1.50	0.433	0.003	0.031	0.039	TT5080
11IRM1.50ISO			M TYPE	0.250	1.50	0.433	0.003	0.031	0.039	
16IRM1.00ISO			M TYPE	0.375	1.00	0.630	0.002	0.024	0.028	
16IRM1.50ISO			M TYPE	0.375	1.50	0.630	0.003	0.031	0.039	
16IRM2.00ISO			M TYPE	0.375	2.00	0.630	0.004	0.039	0.510	
16IRM2.50ISO			M TYPE	0.375	2.50	0.630	0.006	0.043	0.059	
16IRM3.00ISO			M TYPE	0.375	3.00	0.630	0.007	0.043	0.059	
16IR1.50ISO			REGULAR	0.375	1.50	0.630	0.003	0.031	0.039	
16ER1.00ISO	EXTERNAL	RIGHT	REGULAR	0.375	1.00	0.630	0.005	0.028	0.028	
16ERM1.00ISO			M TYPE	0.375	1.00	0.630	0.005	0.028	0.028	
16ERM1.25ISO			M TYPE	0.375	1.25	0.630	0.006	0.031	0.035	
16ER1.50ISO			REGULAR	0.375	1.50	0.630	0.007	0.031	0.039	
16ERM1.50ISO			M TYPE	0.375	1.50	0.630	0.007	0.031	0.039	
16ERM1.75ISO			M TYPE	0.375	1.75	0.630	0.008	0.035	0.047	
16ER2.00ISO			REGULAR	0.375	2.00	0.630	0.010	0.039	0.051	
16ERM2.00ISO			M TYPE	0.375	2.00	0.630	0.010	0.039	0.051	
16ERM2.50ISO			M TYPE	0.375	2.50	0.630	0.012	0.043	0.059	
16ER3.00ISO			M TYPE	0.375	3.00	0.630	0.015	0.047	0.063	

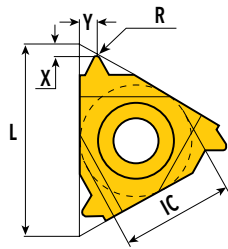

Application:
General Industry

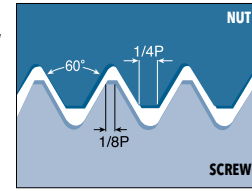

AMERICAN UN FULL PROFILE (ANSI B1, 3M-1986 CLASS 2A/2B)

Designation	Thread Type	Hand	Insert Type	IC (inch)	TPI	L (inch)	R (inch)	X (inch)	Y (inch)	Grade
16IRM12UN	INTERNAL	RIGHT	M TYPE	0.375	12	0.630	0.005	0.043	0.055	TT5080
16IRM16UN					16		0.004	0.035	0.043	
16ERM20UN					20		0.006	0.031	0.035	
16ERM12UN	EXTERNAL				12		0.010	0.043	0.055	
16ERM14UN					14		0.009	0.039	0.047	
16ERM16UN					16		0.007	0.035	0.043	
16ERM18UN		18	0.006	0.031	0.039					

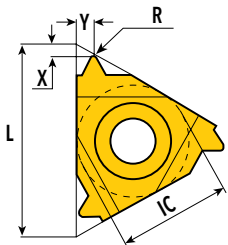

Application:
General Industry, Fittings and
Pipe Couplings

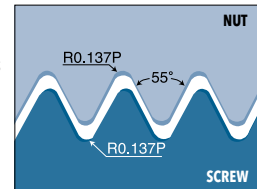

WHITWORTH FULL PROFILE (BS 84-1956 DIN259 MEDIUM CLASS)

Designation	Thread Type	Hand	Insert Type	IC (inch)	TPI	L (inch)	R (inch)	X (inch)	Y (inch)	Grade
16IRM11W	INTERNAL	RIGHT	M TYPE	0.375	11	0.630	0.012	0.043	0.059	TT5080
16IRM14W					14		0.009	0.039	0.047	
16ERM11W	EXTERNAL				11		0.012	0.043	0.059	
16ERM14W					14		0.009	0.039	0.047	
16ERM19W		19	0.003	0.031	0.039					

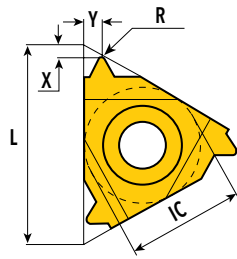

Application:
Steam, Gas and
Water Pipes

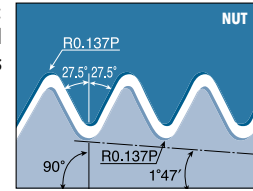

BSPT (BRITISH STANDARD TAPERED THREAD) FULL PROFILE (BS 21-1957)

Designation	Thread Type	Hand	Insert Type	IC (inch)	TPI	L (inch)	R (inch)	X (inch)	Y (inch)	Grade
16IRM11BSPT	INTERNAL	RIGHT	M TYPE	0.375	11	0.630	0.011	0.043	0.059	TT5080
16IRM14BSPT					14					
16ERM11BSPT	EXTERNAL				11					
16ERM14BSPT					14					

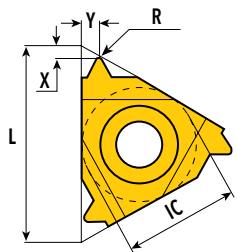

Application:
Steam, Gas and
Water Pipes

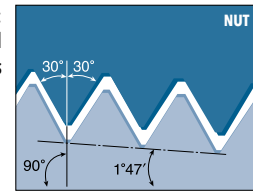

NPT (NATIONAL PIPE TAPERED THREAD) FULL PROFILE (ANSI/ASME B1.20.1-1983)

Designation	Thread Type	Hand	Insert Type	IC (inch)	TPI	L (inch)	R (inch)	X (inch)	Y (inch)	Grade
16IRM8NPT	INTERNAL	RIGHT	M TYPE	0.375	8	0.630	0.006	0.047	0.071	TT5080
16IRM11.5NPT					11.5					
16IRM14NPT					14					
16ERM11.5NPT	EXTERNAL				11.5					
16ERM14NPT					14					

B-TYPE THREADING INSERTS

- Combination of M Type and Regular Type threading inserts
- Molded chipbreaker for strength
- Precise and sharp cutting edges reduce cutting forces
- Improved chip breaking and better chip evacuation
- Better surface quality
- Economical choice

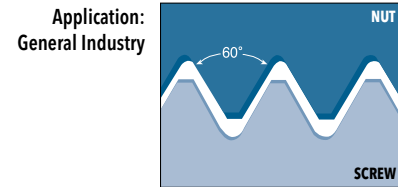
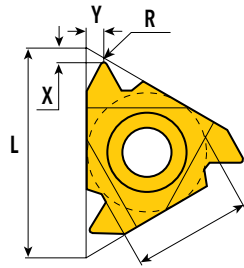
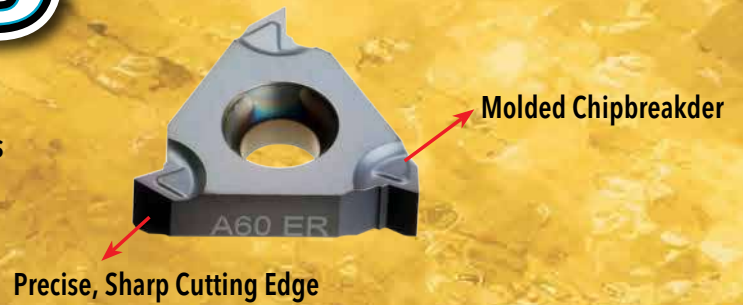

PARTIAL PROFILE 60°

Designation	Thread Type	Hand	IC (inch)	Pitch TPI	Pitch mm	L (inch)	R (inch)	X (inch)	Y (inch)	Grade
16ERBA60	EXTERNAL	RIGHT	0.375	16-48	.5-1.5	0.630	0.002	0.031	0.035	TT9030
16ERBAG60				8-48	.5-3.0		0.002	0.047	0.067	
16ERBG60				8-14	1.75-3.0		0.005	0.047	0.067	
16IRBA60	INTERNAL			16-48	.5-1.5		0.002	0.031	0.035	
16IRBAG60				8-48	.5-3.0		0.002	0.047	0.067	
16IRBG60				8-14	1.75-3.0		0.005	0.047	0.067	

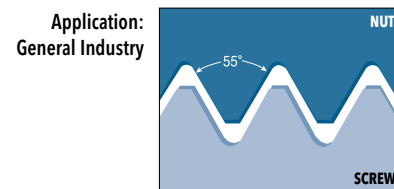
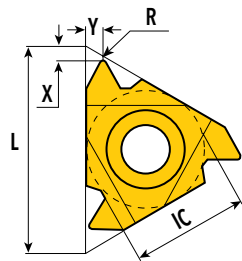

PARTIAL PROFILE 55°

Designation	Thread Type	Hand	IC (inch)	Pitch TPI	Pitch mm	L (inch)	R (inch)	X (inch)	Y (inch)	Grade
16ERBAG55	EXTERNAL	RIGHT	0.375	8-48	.5-3.0	0.630	0.002	0.047	0.067	TT9030
16ERBG55				8-14	1.75-3.0		0.008			
16IRBAG55	INTERNAL			8-48	.5-3.0		0.002			
16IRBG55				8-14	1.75-3.0		0.008			

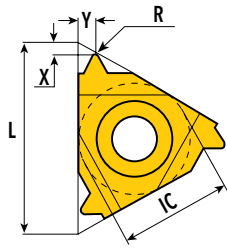

Application:
General Industry

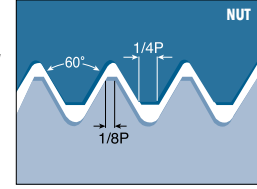

ISO FULL PROFILE (DIN13 12-1986 CLASS 6G/6H)

Designation	Thread Type	Hand	IC (inch)	Pitch mm	L (inch)	R (inch)	X (inch)	Y (inch)	Grade
16ERB0.80ISO	EXTERNAL	RIGHT	0.375	0.8	0.630	0.004	0.024	0.024	TT9030
16ERB1.00ISO				1.00		0.004	0.028	0.028	
16ERB1.25ISO				1.25		0.006	0.031	0.035	
16ERB1.50ISO				1.50		0.007	0.031	0.039	
16ERB1.75ISO				1.75		0.008	0.035	0.047	
16ERB2.00ISO				2.00		0.010	0.039	0.051	
16ERB2.50ISO	INTERNAL	RIGHT	0.375	2.50	0.630	0.012	0.043	0.059	TT9030
16ERB3.00ISO				3.00		0.015	0.047	0.063	
16IRB1.00ISO				1.00		0.002	0.024	0.028	
16IRB1.25ISO				1.25		0.003	0.031	0.035	
16IRB1.50ISO				1.50		0.003	0.031	0.039	
16IRB1.75ISO				1.75		0.004	0.035	0.047	
16IRB2.00ISO	2.00	0.004	0.039	0.510					
16IRB2.50ISO	2.50	0.006	0.043	0.059					
16IRB3.00ISO	3.00	0.007	0.043	0.059					

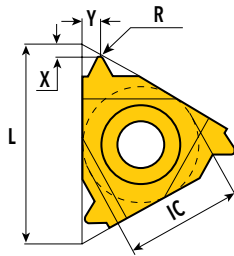

Application:
Steam, Gas and
Water Pipes

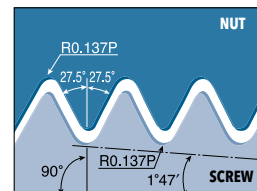

BSPT (BRITISH STANDARD TAPERED THREAD) FULL PROFILE (BS 21-1957)

Designation	Thread Type	Hand	IC (inch)	TPI	L (inch)	R (inch)	X (inch)	Y (inch)	Grade
16ERB11BSPT	EXTERNAL	RIGHT	0.375	11	0.630	0.011	0.043	0.059	TT9030
16ERB14BSPT				14		0.008	0.039	0.047	
16IRB11BSPT	INTERNAL			11		0.011	0.043	0.059	
16IRB14BSPT				14		0.008	0.039	0.047	

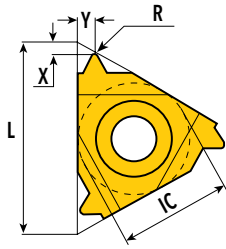

Application:
General Industry

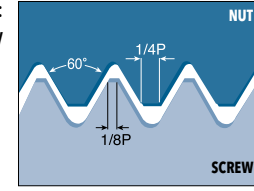

AMERICAN UN FULL PROFILE (ANSI B1, 3M-1986 CLASS 2A/2B)

Designation	Thread Type	Hand	IC (inch)	TPI	L (inch)	R (inch)	X (inch)	Y (inch)	Grade
16ERB8UN	EXTERNAL	RIGHT	0.375	8	0.630	0.016	0.047	0.063	TT9030
16ERB9UN				9		0.014	0.047	0.067	
16ERB10UN				10		0.013	0.043	0.059	
16ERB11UN				11		0.011	0.043	0.059	
16ERB12UN				12		0.010	0.043	0.055	
16ERB13UN				13		0.009	0.039	0.051	
16ERB14UN				14		0.009	0.039	0.047	
16ERB16UN				16		0.007	0.035	0.043	
16ERB18UN				18		0.006	0.031	0.039	
16ERB20UN				20		0.006	0.031	0.035	
16ERB24UN				24		0.005	0.028	0.031	
16IRB8UN				INTERNAL		RIGHT	0.375	8	
16IRB9UN	9	0.007	0.047		0.067				
16IRB10UN	10	0.006	0.043		0.059				
16IRB12UN	12	0.005	0.043		0.055				
16IRB14UN	14	0.004	0.035		0.047				
16IRB16UN	16	0.004	0.035		0.043				
16IRB18UN	18	0.003	0.031		0.039				
16IRB20UN	20	0.002	0.031		0.035				
16IRB24UN	24	0.002	0.028	0.031					

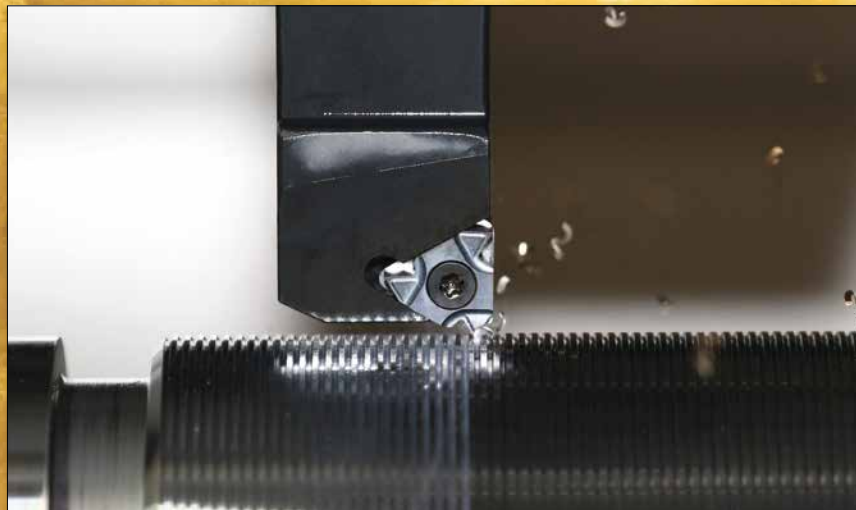

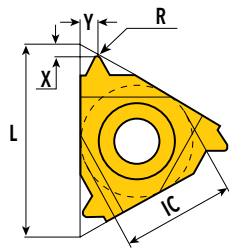

Application:
General Industry, Fittings and
Pipe Couplings

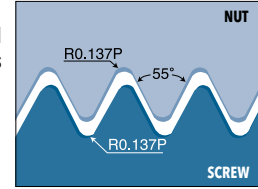

WHITWORTH FULL PROFILE (BS 84-1956 DIN259 MEDIUM CLASS)

Designation	Thread Type	Hand	IC (inch)	TPI	L (inch)	R (inch)	X (inch)	Y (inch)	Grade
16ERB10W	EXTERNAL	RIGHT	0.375	10	0.630	0.012	0.043	0.059	TT9030
16ERB11W				11		0.012	0.043	0.059	
16ERB14W				14		0.009	0.039	0.047	
16ERB16W				16		0.007	0.035	0.043	
16ERB19W				19		0.003	0.031	0.039	
16IRB10W	INTERNAL	RIGHT	0.375	10	0.630	0.012	0.043	0.059	TT9030
16IRB11W				11		0.012	0.043	0.059	
16IRB14W				14		0.009	0.039	0.047	
16IRB16W				16		0.007	0.035	0.043	
16IRB19W				19		0.006	0.031	0.039	

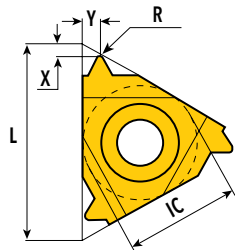

Application:
Steam, Gas and Water
Pipes

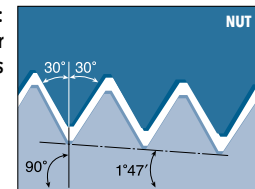

NPT (NATIONAL PIPE TAPERED THREAD) FULL PROFILE (ANSI/ASME B1.20.1-1983)

Designation	Thread Type	Hand	IC (inch)	TPI	L (inch)	R (inch)	X (inch)	Y (inch)	Grade
16ERB8NPT	EXTERNAL	RIGHT	0.375	8	0.630	0.006	0.047	0.071	TT9030
16ERB11.5NPT				11.5		0.004	0.043	0.059	
16ERB14NPT				14		0.002	0.035	0.047	
16ERB18NPT				18		0.002	0.031	0.039	
16IRB8NPT	INTERNAL	RIGHT	0.375	8	0.630	0.006	0.047	0.071	TT9030
16IRB11.5NPT				11.5		0.004	0.043	0.059	
16IRB14NPT				14		0.002	0.035	0.047	

T-CLAMP ULTRA+™

DEEP FACE GROOVING BLADE PRODUCT EXPANSION

- New face grooving blade sizes for larger diameter grooves.
- Capable of face grooving to 1.496" (38mm) depth!
- Blades fully compatible with industry standard blocks (1.26" height).
- Blades use single or double-ended T-Clamp Ultra+ inserts with seat sizes 3, 4, 5 or 6.



234

FINE GOLD 2013/2014

TGBFR/L

DEEP FACE GROOVING BLADES



Face Grooving

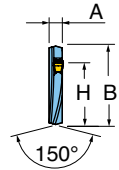
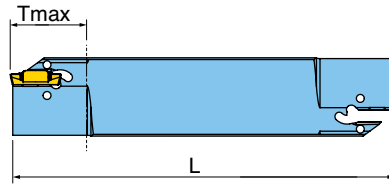
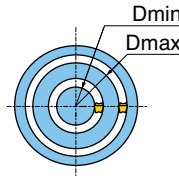

Designation	Insert Seat Size	H (inch)	B (inch)	L (inch)	A (inch)	Tmax (inch)	Dmin (inch)	Dmax (inch)
TGBFL32T20-40-60-3	3	0.976	1.26	5.90	0.205	0.787	1.57	2.36
TGBFL32T20-54-80-3	3	0.976	1.26	5.90	0.205	0.787	2.13	3.15
TGBFL32T25-74-120-3	3	0.976	1.26	5.90	0.205	0.984	2.91	4.72
TGBFL32T25-114-180-3	3	0.976	1.26	5.90	0.205	0.984	4.49	7.09
TGBFL32T25-40-60-4	4	0.976	1.26	5.90	0.205	0.984	1.57	2.36
TGBFL32T25-50-80-4	4	0.976	1.26	5.90	0.205	0.984	1.97	3.15
TGBFL32T30-70-130-4	4	0.976	1.26	5.90	0.205	1.181	2.76	5.12
TGBFL32T30-120-200-4	4	0.976	1.26	5.90	0.205	1.181	4.72	7.87
NEW! TGBFL32T30-200-4	4	0.976	1.26	5.90	0.205	1.181	7.87	INF
TGBFL32T32-60-95-5	5	0.976	1.26	5.90	0.205	1.260	2.36	3.74
TGBFL32T35-85-140-5	5	0.976	1.26	5.90	0.205	1.378	3.35	5.51
TGBFL32T35-130-250-5	5	0.976	1.26	5.90	0.205	1.378	5.12	9.84
NEW! TGBFL32T35-250-5	5	0.976	1.26	5.90	0.205	1.378	9.84	INF
TGBFL32T32-80-180-6	6	0.976	1.26	5.90	0.205	1.260	3.15	7.09
TGBFL32T38-168-300-6	6	0.976	1.26	5.90	0.205	1.496	6.61	11.81
NEW! TGBFL32T38-300-6	6	0.976	1.26	5.90	0.205	1.496	11.81	INF
TGBFR32T20-40-60-3	3	0.976	1.26	5.90	0.205	0.787	1.57	2.36
TGBFR32T20-54-80-3	3	0.976	1.26	5.90	0.205	0.787	2.13	3.15
TGBFR32T25-74-120-3	3	0.976	1.26	5.90	0.205	0.984	2.91	4.72
TGBFR32T25-114-180-3	3	0.976	1.26	5.90	0.205	0.984	4.49	7.09
TGBFR32T25-40-60-4	4	0.976	1.26	5.90	0.205	0.984	1.57	2.36
TGBFR32T25-50-80-4	4	0.976	1.26	5.90	0.205	0.984	1.97	3.15
TGBFR32T30-70-130-4	4	0.976	1.26	5.90	0.205	1.181	2.76	5.12
TGBFR32T30-120-200-4	4	0.976	1.26	5.90	0.205	1.181	4.72	7.87
NEW! TGBFR32T30-200-4	4	0.976	1.26	5.90	0.205	1.181	7.87	INF
TGBFR32T32-60-95-5	5	0.976	1.26	5.90	0.205	1.260	2.36	3.74
TGBFR32T35-85-140-5	5	0.976	1.26	5.90	0.205	1.378	3.35	5.51
TGBFR32T35-130-250-5	5	0.976	1.26	5.90	0.205	1.378	5.12	9.84
NEW! TGBFR32T35-250-5	5	0.976	1.26	5.90	0.205	1.378	9.84	INF
TGBFR32T32-80-180-6	6	0.976	1.26	5.90	0.205	1.260	3.15	11.81
TGBFR32T38-168-300-6	6	0.976	1.26	5.90	0.205	1.496	6.61	7.09
NEW! TGBFR32T38-300-6	6	0.976	1.26	5.90	0.205	1.496	11.81	INF

Use inserts TDC/TSC, TDJ/TSJ, TD XU, TDT, TDFT.
NOTE: Insert Extractor Sold Separately.

HARDWARE			
	EDG-33B	TTBU_-32	TTBN_-32

T-CLAMP ULTRA+™

INTERNAL TURN/GROOVE BARS FOR DEEPER ID GROOVES

NEW!

- Product expansion to existing TTIR series tools.
- Extended T-max dimension for grooves of up to .472" (12mm) per side!
- All bars are coolant through.
- Bars use single or double-ended T-Clamp Ultra+ inserts with seat sizes 3, 4, 5 or 6.
- 1.00", 1.25" and 1.50" right hand bars are stocked.

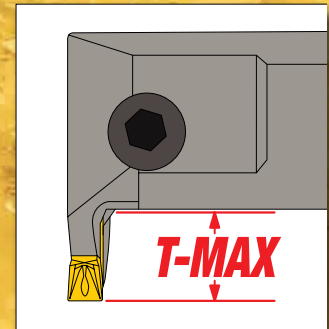

• INSERT SELECTION FOR ID GROOVING

Insert	Min. Diameter	Remark
TDC/J 2	1.57	Use TDIT or TDXU type if workpiece internal diameter is smaller than Min. Diameter
TDC/J 3	1.97	
TDC/J 4	1.97	
TDC/J 5	2.36	
TDC/J 6	2.36	
TDT 3	1.57	
TDT 4	1.57	
TDT 5	1.97	
TDT 6	1.97	
TDT 8	2.60	

TTIR/L

INTERNAL TURNING, GROOVING AND PROFILING HOLDERS

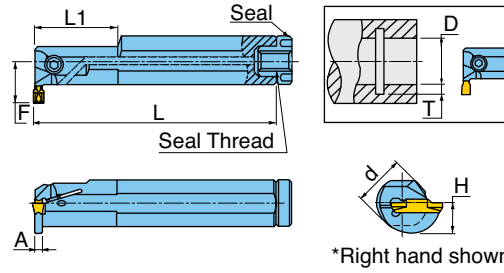

Designation	Insert Seat Size	d (inch)	A (inch)	H (inch)	F (inch)	L (inch)	L1 (inch)	Tmax (inch)	Dmin (inch)	Seal	Seal Thread	Screw	Wrench	Torque (lb-in)
TTIL16-2C	2	0.63	0.063	0.30	0.65	4.9	-	0.33	0.98	PL16		SH M5X0.8X10		
TTIR16-2C		0.63	0.063	0.30	0.65	4.9	-	0.33	0.98	PL16		SH M5X0.8X10		
TTIR19-2C		0.75	0.063	0.33	0.62	6.3	1.57	0.24	0.98	PL075		SH M5X0.8X12		
TTIR25.4-2C	3	1.00	0.063	0.45	0.69	8.0	1.57	0.2	0.98	PL100		SH M5X0.8X16		
TTIL19-3C		0.75	0.083	0.33	0.62	6.5	1.57	0.26	0.98	PL075		SH M5X0.8X12		
TTIR19-3C		0.75	0.083	0.33	0.62	6.5	1.57	0.26	0.98	PL075		SH M5X0.8X12		
TTIL25.4-3C	3	1.00	0.083	0.45	0.69	8.0	1.57	0.23	0.98	PL100		SH M5X0.8X16		
TTIR25.4-3C		1.00	0.083	0.45	0.69	8.0	1.57	0.23	0.98	PL100		SH M5X0.8X16		
TTIR25.4-3C-T8		1.00	0.094	0.45	0.85	8.0	1.57	0.31	1.26	PL100		SH M5X0.8X16		
TTIR31.7-3C-T10	4	1.25	0.094	0.55	1.06	10.0	2.36	0.39	1.57	PL125		SH M5X0.8X20		
TTIR38.1-3C-T12		1.50	0.094	0.70	1.30	12.0	2.56	0.47	1.97	PL150		SH M5X0.8X25	L-W4	49.0
TTIL19-4C		0.75	0.114	0.33	0.62	6.5	1.57	0.26	0.98	PL075		SH M5X0.8X20		
TTIR19-4C	4	0.75	0.114	0.33	0.62	6.5	1.57	0.26	0.98	PL075		SH M5X0.8X20		
TTIL25.4-4C		1.00	0.114	0.45	0.69	8.0	1.57	0.23	0.98	PL100		SH M5X0.8X25		
TTIR25.4-4C		1.00	0.114	0.45	0.69	8.0	1.57	0.23	0.98	PL100		SH M5X0.8X25		
TTIR25.4-4C-T8	4	1.00	0.118	0.45	0.85	8.0	1.57	0.31	1.26	PL100		SH M5X0.8X16		
TTIL31.7-4C		1.25	0.114	0.55	0.82	10.0	2.36	0.26	1.26	PL125	NPT 1/8	SH M5X0.8X16		
TTIR31.7-4C		1.25	0.114	0.55	0.82	10.0	2.36	0.26	1.26	PL125	NPT 1/8	SH M5X0.8X16		
TTIR31.7-4C-T10	5	1.25	0.118	0.55	1.06	10.0	2.36	0.39	1.57	PL125		SH M5X0.8X20		
TTIR38.1-4C-T12		1.50	0.118	0.70	1.30	12.0	2.56	0.47	1.97	PL150		SH M5X0.8X25		
TTIL25.4-5C		1.00	0.154	0.45	0.68	8.0	1.57	0.26	1.26	PL100		SH M5X0.8X25		
TTIR25.4-5C	5	1.00	0.154	0.45	0.68	8.0	1.57	0.26	1.26	PL100		SH M6X1X16		
TTIL31.7-5C		1.25	0.154	0.55	0.82	10.0	2.36	0.26	1.26	PL125		SH M6X1X25		
TTIR31.7-5C		1.25	0.154	0.55	0.82	10.0	2.36	0.26	1.26	PL125		SH M6X1X25		
TTIR31.7-5C-T10	6	1.25	0.151	0.55	1.06	10.0	2.36	0.39	1.57	PL125		SH M6X1X20		
TTIR38.1-5C-T12		1.50	0.151	0.70	1.30	12.0	2.56	0.47	1.97	PL150		SH M6X1X25		
TTIL31.7-6C		1.25	0.193	0.55	0.82	10.0	2.36	0.26	1.26	PL125		SH M6X1X25		
TTIR31.7-6C	6	1.25	0.193	0.55	0.82	10.0	2.36	0.26	1.26	PL125		SH M6X1X20	L-W5	71.0
TTIR31.7-6C-T10		1.25	0.190	0.55	1.06	10.0	2.36	0.39	1.57	PL125		SH M6X1X20		
TTIR38.1-6C-T12		1.50	0.190	0.70	1.30	12.0	2.56	0.47	1.97	PL150		SH M6X1X25		
TTIL31.7-8C	8	1.25	0.232	0.57	0.84	10.0	2.36	0.26	1.46	PL125		SH M6X1X25		
TTIR31.7-8C		1.25	0.232	0.57	0.84	10.0	2.36	0.26	1.46	PL125		SH M6X1X25		
TTIL38.1-8C		1.50	0.232	0.70	1.02	12.0	2.56	0.26	1.65	PL150		SH M6X1X25		
TTIR38.1-8C	1.50	0.232	0.70	1.02	12.0	2.56	0.26	1.65	PL150		SH M6X1X25			

Use inserts TDC/TSC, TDJ/TSJ for grooving
Use inserts TDXU, TDT, TDIT for grooving and turning

TOCLAMP ULTRA+

MODULAR SYSTEM PRODUCT EXPANSION

- New cartridges for 1.4mm and 2mm wide inserts.
- New external cartridges with longer T-max dimensions for deeper machining.
- New face grooving cartridges for larger diameter grooves.
- New C8 holder for Quick-Change product line.

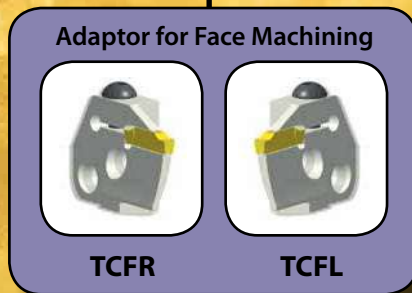
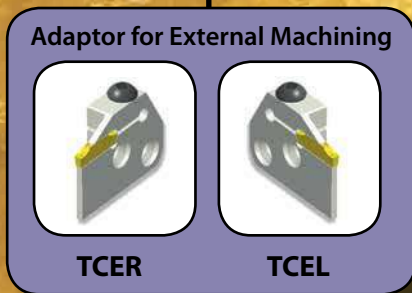
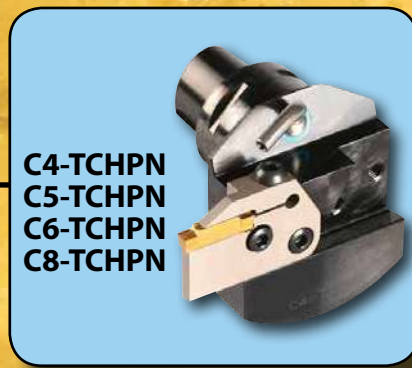
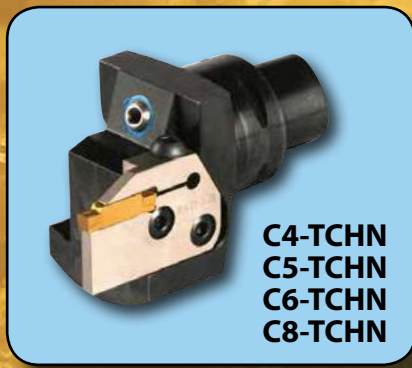

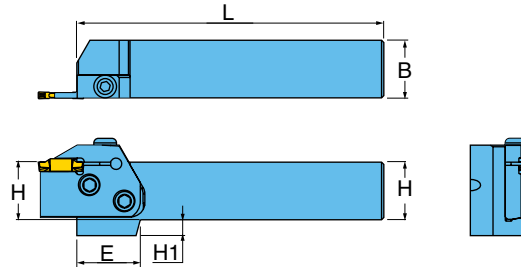

TCHR/L

PARALLEL HOLDERS FOR MODULAR BLADES



Designation	ISO Number	H (inch)	B (inch)	L (inch)	E (inch)	H1 (inch)
TCHL19	TCHL19	0.750	0.750	6.000	1.380	0.470
TCHL25.4	TCHL25.4	1.000	1.000	6.000	1.100	0.280
TCHL31.8	TCHL31.8	1.250	1.250	6.000	1.100	-
TCHR19	TCHR19	0.750	0.750	6.000	1.380	0.470
TCHR25.4	TCHR25.4	1.000	1.000	6.000	1.100	0.280
TCHR31.8	TCHR31.8	1.250	1.250	6.000	1.100	-

HARDWARE						
	Screw	EXTERNAL LH ADAPTER	EXTERNAL RH ADAPTER	FACE LH ADAPTER	FACE RH ADAPTER	Wrench
TCHL19	TS60190I	TCEL	-	-	TCFR	L-W4
TCHL25.4	TS60190I	TCEL	-	-	TCFR	L-W4
TCHL31.8	TS60190I	TCEL	-	-	TCFR	L-W4
TCHR19	TS60190I	-	TCER	TCFL	-	L-W4
TCHR25.4	TS60190I	-	TCER	TCFL	-	L-W4
TCHR31.8	TS60190I	-	TCER	TCFL	-	L-W4

Adapter and holder selection



TCHR

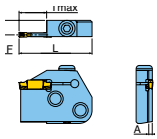

TCER XX

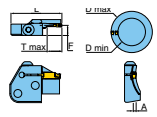

TCFL XX



TCHL

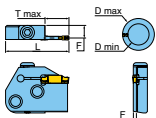

TCEL XX

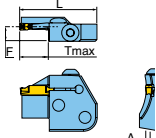

TCFR XX

TCHPR/L

PERPENDICULAR HOLDERS FOR MODULAR BLADES



OD Turning



Face Groove Turn

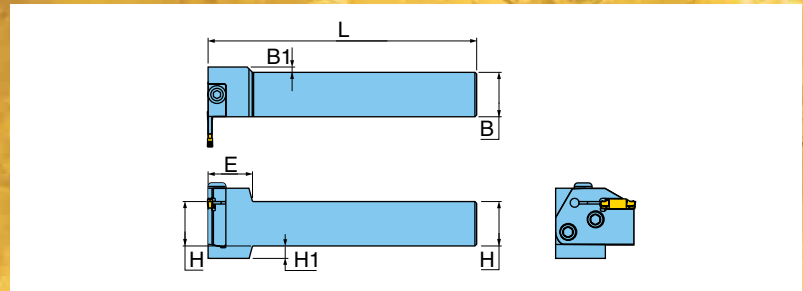

Designation	H (inch)	B (inch)	L (inch)	E (inch)	B1 (inch)	H1 (inch)
TCHPL19	0.750	0.750	6.000	0.980	0.295	0.470
TCHPL25.4	1.000	1.000	6.000	0.980	0.118	0.280
TCHPL31.8	1.250	1.250	6.000	0.980	0.295	-
TCHPR19	0.750	0.750	6.000	0.980	0.295	0.470
TCHPR25.4	1.000	1.000	6.000	0.980	0.118	0.280
TCHPR31.8	1.250	1.250	6.000	0.980	0.295	-

HARDWARE						
	Screw	EXTERNAL LH ADAPTER	EXTERNAL RH ADAPTER	FACE LH ADAPTER	FACE RH ADAPTER	Wrench
TCHPL19	TS60190I	-	TCER	TCFL	-	L-W4
TCHPL25.4	TS60190I	-	TCER	TCFL	-	L-W4
TCHPL31.8	TS60190I	-	TCER	TCFL	-	L-W4
TCHPR19	TS60190I	TCEL	-	-	TCFR	L-W4
TCHPR25.4	TS60190I	TCEL	-	-	TCFR	L-W4
TCHPR31.8	TS60190I	TCEL	-	-	TCFR	L-W4

Adapter and holder selection

TCHPR

TCEL XX

TCFR XX

TCHPL

TCER XX

TCFL XX

TCHN & TCHPN QUICK-CHANGE*

COADAPTER™

ADAPTER FOR EXTERNAL TURNING AND GROOVING (LEFT HAND OR RIGHT HAND) OR FACE TURNING AND GROOVING



OD Turning



Face Groove Turn

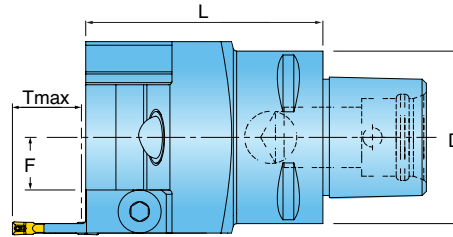

Designation	L (inch)	D (mm)	F (inch)
C4-TCHN	2.16	40 mm	0.480
C5-TCHN	2.28	50 mm	0.677
C6-TCHN	2.36	63 mm	0.874
NEW! C8-TCHN	2.56	80 mm	1.197

*compatible with Sandvik's COROMANT CAPTO® (**) system.

HARDWARE							
	TS60190I	TCFL	TCEL	TCFR	TCER	L-W4	NZ125

ADAPTER FOR EXTERNAL TURNING AND GROOVING (LEFT HAND OR RIGHT HAND) OR FACE TURNING AND GROOVING



OD Turning



Face Grooving

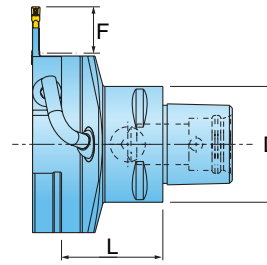

Designation	L (inch)	D (mm)	F (inch)
C4-TCHPN	1.38	40 mm	1.20
C5-TCHPN	1.57	50 mm	1.40
C6-TCHPN	1.65	63 mm	1.40
NEW! C8-TCHPN	2.17	80 mm	1.67

*compatible with Sandvik's COROMANT CAPTO® (**) system.

HARDWARE								
	TS60190I	TCFL	TCEL	TCFR	TCER	L-W4	NZ125	NZP5

(**) The trademark COROMANT CAPTO® is owned by Sandvik Intellectual Property AB.

TCEL

ADAPTER FOR EXTERNAL TURNING AND GROOVING
(LEFT HAND)

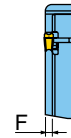
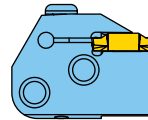
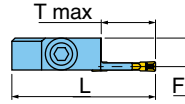

Designation	Insert Seat Size	L (inch)	A (inch)	F (inch)	Tmax (inch)
NEW! TCEL1.4T12	1	1.61	0.039	0.374	0.472
NEW! TCEL2T16	2	1.77	0.071	0.358	0.630
NEW! TCEL2T22	2	2.01	0.071	0.358	0.866
TCEL3T16	3	1.77	0.094	0.346	0.630
NEW! TCEL3T22	3	2.01	0.094	0.346	0.866
TCEL4T16	4	1.77	0.118	0.335	0.630
NEW! TCEL4T22	4	2.01	0.118	0.335	0.866
TCEL5T20	5	1.93	0.157	0.315	0.787
NEW! TCEL5T25	5	2.13	0.157	0.315	0.984
TCEL6T20	6	1.93	0.197	0.295	0.787
NEW! TCEL6T25	6	2.13	0.197	0.295	0.984
TCEL8T25	8	2.13	0.236	0.000	0.984

Use Holders TCHL, TCHPR, TCHN, TCHPN. Use inserts TDC/TSC*, TDJ/TSJ*, TD XU, TDT.

*Grooving only

HARDWARE				
	Holder	Holder	Clamp Screw	Clamp Screw Wrench
	TCHL	TCHPR	BHM6X1X20	L-W4

TCER

ADAPTER FOR EXTERNAL TURNING AND GROOVING (RIGHT HAND)

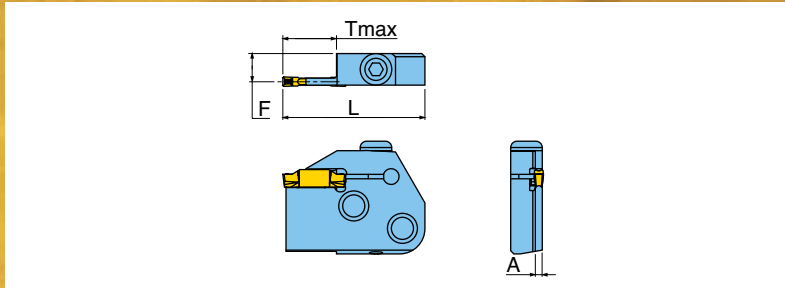

Designation	Insert Seat Size	L (inch)	A (inch)	F (inch)	Tmax (inch)
NEW! TCER1.4T12	1	1.61	0.039	0.374	0.472
NEW! TCER2T16	2	1.77	0.071	0.358	0.630
NEW! TCER2T22	2	2.01	0.071	0.358	0.866
TCER3T16	3	1.77	0.094	0.346	0.630
NEW! TCER3T22	3	2.01	0.094	0.346	0.866
TCER4T16	4	1.77	0.118	0.335	0.630
NEW! TCER4T22	4	2.01	0.118	0.335	0.866
TCER5T20	5	1.93	0.157	0.315	0.787
NEW! TCER5T25	5	2.13	0.157	0.315	0.984
TCER6T20	6	1.93	0.197	0.295	0.787
NEW! TCER6T25	6	2.13	0.197	0.295	0.984
TCER8T25	8	2.13	0.236	0.000	0.984

Use Holders TCHR, TCHPL, TCHN, TCHPN. Use inserts TDC/TSC*, TDJ/TSJ*, TDXU, TDT.

*Grooving only

HARDWARE				
	TCHR	TCHPL	BHM6X1X20	L-W4

TCFR

ADAPTER FOR EXTERNAL FACE GROOVING AND TURNING (RIGHT HAND)

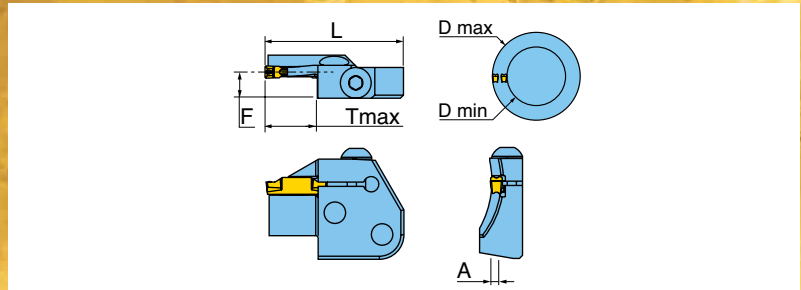

Designation	Insert Seat Size	L (inch)	F (inch)	Tmax (inch)	Dmin (inch)	Dmax (inch)
TCFR3T12-40-55RN	3	1.77	0.350	0.472	1.58	2.17
TCFR3T12-55-75RN	3	1.77	0.350	0.472	2.17	2.95
TCFR3T12-75-100RN	3	1.77	0.350	0.472	2.95	3.94
TCFR3T12-100-140RN	3	1.77	0.350	0.472	3.94	5.51
TCFR3T12-140-200RN	3	1.77	0.350	0.472	5.51	7.87
TCFR4T16-50-70RN	4	1.77	0.335	0.630	1.97	2.76
TCFR4T16-70-100RN	4	1.77	0.335	0.630	2.76	3.94
TCFR4T16-100-150RN	4	1.77	0.335	0.630	3.94	5.91
TCFR4T16-150-250RN	4	1.77	0.335	0.630	5.91	9.84
NEW! TCFR4T16-250RN	4	1.77	0.335	0.630	9.84	INF
TCFR5T20-55-80RN	5	1.97	0.315	0.787	2.17	3.15
TCFR5T20-80-120RN	5	1.97	0.315	0.787	3.15	4.72
TCFR5T20-120-180RN	5	1.97	0.315	0.787	4.72	7.09
TCFR5T20-180-300RN	5	1.97	0.315	0.787	7.09	11.81
NEW! TCFR5T20-300RN	5	2.17	0.315	0.787	11.81	INF
TCFR6T25-60-90RN	6	2.17	0.305	0.984	2.36	3.54
TCFR6T25-90-150RN	6	2.17	0.305	0.984	3.54	5.91
TCFR6T25-150-250RN	6	2.17	0.305	0.984	5.91	9.84
TCFR6T25-250-400RN	6	2.17	0.305	0.984	9.84	15.75
NEW! TCFR6T25-400RN	6	2.17	0.305	0.984	15.75	INF

Use Holders TCHL, TCHPR, TCHN, TCHPN. Use inserts TDC/TSC*, TDJ/TSJ*, TD XU, TDT, TDFT.

*Grooving only

HARDWARE				
	Holder	Holder	Clamp Screw	Wrench
	TCHL	TCHPR	BHM6X1X20	L-W4

TCFL

ADAPTER FOR EXTERNAL FACE GROOVING AND TURNING (LEFT HAND)

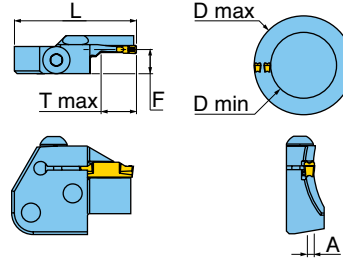

Designation	Insert Seat Size	L (inch)	F (inch)	Tmax (inch)	Dmin (inch)	Dmax (inch)
TCFL3T12-40-55RN	3	1.77	0.350	0.472	1.58	2.17
TCFL3T12-55-75RN	3	1.77	0.350	0.472	2.17	2.95
TCFL3T12-75-100RN	3	1.77	0.350	0.472	2.95	3.94
TCFL3T12-100-140RN	3	1.77	0.350	0.472	3.94	5.51
TCFL3T12-140-200RN	3	1.77	0.350	0.472	5.51	7.87
TCFL4T16-50-70RN	4	1.77	0.335	0.630	1.97	2.76
TCFL4T16-70-100RN	4	1.77	0.335	0.630	2.76	3.94
TCFL4T16-100-150RN	4	1.77	0.335	0.630	3.94	5.91
TCFL4T16-150-250RN	4	1.77	0.335	0.630	5.91	9.84
NEW! TCFL4T16-250RN	4	1.77	0.335	0.630	9.84	INF
TCFL5T20-55-80RN	5	1.97	0.315	0.787	2.17	3.15
TCFL5T20-80-120RN	5	1.97	0.315	0.787	3.15	4.72
TCFL5T20-120-180RN	5	1.97	0.315	0.787	4.72	7.09
TCFL5T20-180-300RN	5	1.97	0.315	0.787	7.09	11.81
NEW! TCFL5T20-300RN	5	2.17	0.315	0.787	11.81	INF
TCFL6T25-60-90RN	6	2.17	0.305	0.984	2.36	3.54
TCFL6T25-90-150RN	6	2.17	0.305	0.984	3.54	5.91
TCFL6T25-150-250RN	6	2.17	0.305	0.984	5.91	9.84
TCFL6T25-250-400RN	6	2.17	0.305	0.984	9.84	15.75
NEW! TCFL6T25-400RN	6	2.17	0.305	0.984	15.75	INF

Use Holders TCHR, TCHPL, TCHN, TCHPN. Use inserts TDC/TSC*, TDJ/TSJ*, TD XU, TDT, TDF.

*Grooving only.

HARDWARE				
	TCHR	TCHPL	BHM6X1X20	L-W4

TOCLAMP ULTRA+

10MM & .375" WIDE INSERTS & HOLDERS

- New, larger insert widths for increased material removal rates
- TDT chip breaker for grooving and turning applications
- Double-ended inserts for increased economy
- Right hand and left hand holders with 1", 1.25" and 1.50" shanks.



TTER/L

HOLDER FOR 10MM AND .375" INSERTS



Face Grooving

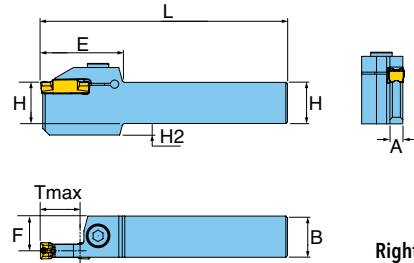

Right-hand holder shown

Designation	Insert Seat Size	F (inch)	L (inch)	H (inch)	B (inch)	E (inch)	H2 (inch)	Tmax (inch)	A* (inch)
TTEL25.4-10	10	0.846	6.0	1.00	1.00	1.97	0.276	0.984	0.309
TTEL31.8-10	10	1.094	7.0	1.25	1.25	1.97	-	0.984	0.309
TTEL38.1-10	10	1.346	8.0	1.50	1.50	1.97	-	0.984	0.309
TTER25.4-10	10	0.846	6.0	1.00	1.00	1.97	0.276	0.984	0.309
TTER31.8-10	10	1.094	7.0	1.25	1.25	1.97	-	0.984	0.309
TTER38.1-10	10	1.346	8.0	1.50	1.50	1.97	-	0.984	0.309

* "A" is the width of the support blade on the holder, NOT the insert.

HARDWARE



Screw



Wrench

SHM8X1.25X25

L-W6

TDT

INSERTS FOR EXTERNAL TURNING AND GROOVING



OD Turning



OD Grooving

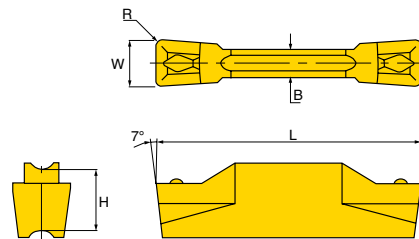

Designation	Insert Seat Size	W ±.0008 (inch)	W ±.02 (mm)	R ±.002 (inch)	B (inch)	L (inch)	H (inch)	Grade TT6080	Grade TT9080
TDT9.52E-0.80	10	0.375	9.52	0.031	0.315	1.181	0.185	•	•
TDT9.52E-1.20	10	0.375	9.52	0.047	0.315	1.181	0.185	•	•
TDT9.52E-4.76	10	0.375	9.52	0.187	0.315	1.181	0.185	•	•
TDT10.00E-0.80	10	0.394	10.00	0.031	0.315	1.181	0.185	•	•
TDT10.00E-1.20	10	0.394	10.00	0.047	0.315	1.181	0.185	•	•
TDT10.00E-2.00	10	0.394	10.00	0.079	0.315	1.181	0.185	•	•
TDT10.00E-5.00	10	0.394	10.00	0.197	0.315	1.181	0.185	•	•

• Marked: Standard items

T-CLAMP ULTRA+™

NEW GRADE TT9080 PHASING OUT GRADE TT9030

Following the successful testing and application of GoldRush grade TT9080 in our T-Clamp Ultra Plus parting and grooving product line, Ingersoll is pleased to announce the addition of this grade for all T-Clamp Ultra Plus inserts.

Grade TT9080 features a modified PVD coating with an outer layer of TiN making it gold in appearance. Additionally, our post-coat GoldRush treatment provides a more stable cutting edge that reduces build-up and chipping, resulting in prolonged tool life. As a result of this change, grade TT9030 will be phased out in the coming months as stock is depleted.

Below you will find a list of the current TT9030 inserts along with the replacement inserts in TT9080. For further questions please contact Ingersoll's Turning Product Management team.

PHASE-OUT

REPLACEMENT

Item Number	ISO Description		Item Number	ISO Description
6000490	TDC2 TT9030	➔	6000998	TDC2 TT9080
6000660	TDC2-15R TT9030	➔	6110856	TDC2-15R TT9080
6000654	TDC2-15RS TT9030	➔	6110855	TDC2-15RS TT9080
6000661	TDC2-6R TT9030	➔	6110857	TDC2-6R TT9080
6000501	TDC2-6RS TT9030	➔	6110851	TDC2-6RS TT9080
6000491	TDC3 TT9030	➔	6000999	TDC3 TT9080
6000662	TDC3-15L TT9030	➔	6110858	TDC3-15L TT9080
6000663	TDC3-15R TT9030	➔	6110859	TDC3-15R TT9080
6000630	TDC3-6L TT9030	➔	6110854	TDC3-6L TT9080
6000761	TDC3-6LS TT9030	➔	6110863	TDC3-6LS TT9080
6000546	TDC3-6R TT9030	➔	6110852	TDC3-6R TT9080
6000664	TDC3-6RS TT9030	➔	6110860	TDC3-6RS TT9080
6000628	TDC4-4L TT9030	➔	6110853	TDC4-4L TT9080
6000665	TDC4-4R TT9030	➔	6110861	TDC4-4R TT9080
6000651	TDC5 TT9030	➔	6001104	TDC5 TT9080
6000666	TDC5-4R TT9030	➔	6110862	TDC5-4R TT9080
6000652	TDC6 TT9030	➔	6001105	TDC6 TT9080
6000639	TDC8 TT9030	➔	6001106	TDC8 TT9080
6401397	TDIM 2E-0.15 TT9030	➔	6402249	TDIM 2E-0.15 TT9080
6401240	TDIM 3E-0.2 TT9030	➔	6402129	TDIM 3E-0.2 TT9080
6401684	TDIP1.00-0.10 TT9030	➔	6402250	TDIP1.00-0.10 TT9080
6401685	TDIP1.00-0.50 TT9030	➔	6402251	TDIP1.00-0.50 TT9080
6401686	TDIP1.20-0.00 TT9030	➔	6402252	TDIP1.20-0.00 TT9080
6401687	TDIP1.40-0.00 TT9030	➔	6402253	TDIP1.40-0.00 TT9080
6401688	TDIP1.50-0.10 TT9030	➔	6402254	TDIP1.50-0.10 TT9080
6401689	TDIP2.00E-0.10 TT9030	➔	6402255	TDIP2.00E-0.10 TT9080
6401697	TDIP2.00E-0.20 TT9030	➔	6402130	TDIP2.00E-0.20 TT9080
6401690	TDIP2.00E-1.00 TT9030	➔	6402256	TDIP2.00E-1.00 TT9080
6401691	TDIP2.50E-0.20 TT9030	➔	6402257	TDIP2.50E-0.20 TT9080
6401692	TDIP3.00E-0.20 TT9030	➔	6402258	TDIP3.00E-0.20 TT9080
6000737	TDJ1.4 TT9030	➔	6000914	TDJ1.4 TT9080
6000671	TDJ2-15L TT9030	➔	6110868	TDJ2-15L TT9080
6000672	TDJ2-15LS TT9030	➔	6110869	TDJ2-15LS TT9080
6000673	TDJ2-15R TT9030	➔	6110870	TDJ2-15R TT9080

PHASE-OUT

REPLACEMENT

Item Number	ISO Description		Item Number	ISO Description
6000674	TDJ2-15RS TT9030	➔	6000768	TDJ2-15RS TT9080
6000675	TDJ2-6L TT9030	➔	6110871	TDJ2-6L TT9080
6000676	TDJ2-6R TT9030	➔	6110872	TDJ2-6R TT9080
6000552	TDJ2-6RS TT9030	➔	6110867	TDJ2-6RS TT9080
6000677	TDJ2-8L TT9030	➔	6110873	TDJ2-8L TT9080
6000678	TDJ2-8R TT9030	➔	6110874	TDJ2-8R TT9080
6000679	TDJ3-15L TT9030	➔	6110875	TDJ3-15L TT9080
6000680	TDJ3-15R TT9030	➔	6110876	TDJ3-15R TT9080
6000681	TDJ3-15RS TT9030	➔	6110877	TDJ3-15RS TT9080
6000682	TDJ3-6L TT9030	➔	6110878	TDJ3-6L TT9080
6000594	TDJ3-6R TT9030	➔	6000783	TDJ3-6R TT9080
6000489	TDJ4 TT9030	➔	6001110	TDJ4 TT9080
6000683	TDJ4-4R TT9030	➔	6110879	TDJ4-4R TT9080
6000515	TDJ5 TT9030	➔	6001111	TDJ5 TT9080
6000516	TDJ6 TT9030	➔	6001112	TDJ6 TT9080
6401052	TDT1.00-0.00 TT9030	➔	6402307	TDT1.00-0.00 TT9080
6401053	TDT1.30-0.00 TT9030	➔	6402308	TDT1.30-0.00 TT9080
6401054	TDT1.60-0.10 TT9030	➔	6402309	TDT1.60-0.10 TT9080
6401055	TDT1.85-0.10 TT9030	➔	6402310	TDT1.85-0.10 TT9080
6401056	TDT2.15-0.15 TT9030	➔	6402311	TDT2.15-0.15 TT9080
6401057	TDT2.65-0.15 TT9030	➔	6110883	TDT2.65-0.15 TT9080
6401058	TDT3.00E-0.20 TT9030	➔	6402277	TDT3.00E-0.20 TT9080
6400841	TDT3.00E-1.50 TT9030	➔	6402317	TDT3.00E-1.50 TT9080
6401014	TDT3E-0.4 TT9030	➔	6402272	TDT3E-0.4 TT9080
6401059	TDT3.15-0.15 TT9030	➔	6110884	TDT3.15-0.15 TT9080
6401016	TDT4.00E-0.40 TT9030	➔	6402010	TDT4.00E-0.40 TT9080
6401060	TDT4.00E-0.80 TT9030	➔	6402011	TDT4.00E-0.80 TT9080
6401017	TDT4.00E-2.00 TT9030	➔	6402318	TDT4.00E-2.00 TT9080
6401013	TDT4E-0.4 TT9030	➔	6402273	TDT4E-0.4 TT9080
6401061	TDT4.15-0.15 TT9030	➔	6110885	TDT4.15-0.15 TT9080
6401063	TDT5.00E-0.40 TT9030	➔	6402283	TDT5.00E-0.40 TT9080
6401064	TDT5.00E-0.80 TT9030	➔	6402284	TDT5.00E-0.80 TT9080
6401065	TDT5.00E-2.50 TT9030	➔	6402319	TDT5.00E-2.50 TT9080
6400632	TDT6.00E-0.80 TT9030	➔	6402286	TDT6.00E-0.80 TT9080
6401066	TDT6.00E-1.20 TT9030	➔	6402287	TDT6.00E-1.20 TT9080
6401067	TDT6.00E-3.00 TT9030	➔	6402320	TDT6.00E-3.00 TT9080
6401069	TDT8.00E-1.20 TT9030	➔	6402289	TDT8.00E-1.20 TT9080
6401024	TDXU3E-0.3 TT9030	➔	6401297	TDXU3E-0.3 TT9080
6401001	TDXU4E-0.4 TT9030	➔	6401280	TDXU4E-0.4 TT9080
6401025	TDXU5E-0.4 TT9030	➔	6402155	TDXU5E-0.4 TT9080
6401445	TDXU6E-0.4 TT9030	➔	6402083	TDXU6E-0.4 TT9080
6401520	TDXU6E-0.8 TT9030	➔	6402084	TDXU6E-0.8 TT9080
6401028	TDXU8E-0.8 TT9030	➔	6402085	TDXU8E-0.8 TT9080
6000505	TSC2 TT9030	➔	6001119	TSC2 TT9080
6000661	TSC2-6R TT9030	➔	6110865	TSC2-6R TT9080
6000506	TSC3 TT9030	➔	6001120	TSC3 TT9080
6000547	TSC3-6R TT9030	➔	6110864	TSC3-6R TT9080
6000669	TSC5 TT9030	➔	6001122	TSC5 TT9080
6000804	TSC8 TT9030	➔	6001124	TSC8 TT9080
6000502	TSJ2 TT9030	➔	6001113	TSJ2 TT9080
6000503	TSJ3 TT9030	➔	6001114	TSJ3 TT9080
6000761	TSJ3-6LS TT9030	➔	6110882	TSJ3-6LS TT9080
6000684	TSJ3-6R TT9030	➔	6110880	TSJ3-6R TT9080
6000504	TSJ4 TT9030	➔	6001115	TSJ4 TT9080
6000967	TSJ5 TT9030	➔	6001116	TSJ5 TT9080

T_OGROOVE™

INSERT FOR WIDE GROOVING APPLICATIONS

- Perfect for applications like ball bearings, taper roller bearings and miniature machined parts.
- Insert holder shank size*:
 - Inch: .500, .625, .750, 1.000, 1.250
 - Metric: 12x12, 16x16, 20x20, 25x25, 32x32
- Carbide Grades**:
 - P40A for Steel
 - K10 for Cast Iron
- Blank Widths (W):
 - 10mm, 15mm, 20mm, 25mm

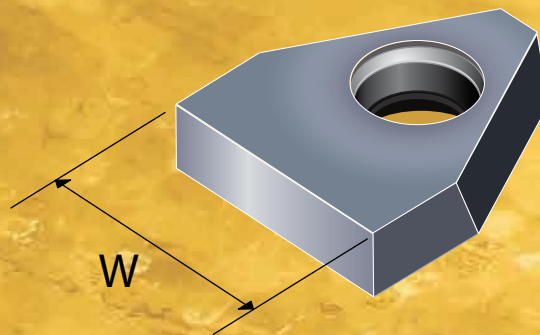
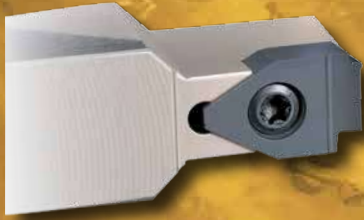

* Holders custom designed and manufactured to match insert form.
** Coated grades can also be provided.

250

FINE GOLD 2013/2014

TGUX Semi-Finished Blank for External Profiles

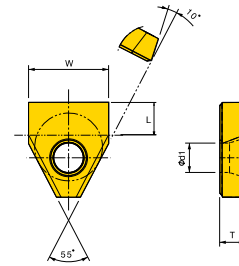
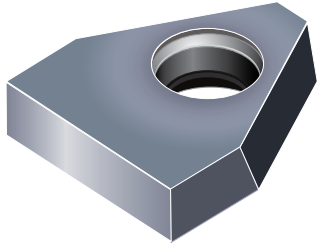

Designation	W		T		D1		L		Grade	
	(mm)	(inch)	(mm)	(inch)	(mm)	(inch)	(mm)	(inch)	K10	P40A
TGUX1004	10.2	0.402	4.76	0.188	5.5	0.217	5.85	0.230	•	•
TGUX1504	15.2	0.598	4.76	0.188	5.5	0.217	5.85	0.230	•	•
TGUX2006	20.2	0.795	6.35	0.250	6	0.236	9.35	0.368	•	•
TGUX2506	25.2	0.992	6.35	0.250	6	0.236	9.25	0.364	•	•

• Marked: Standard items

TTLEN Holders

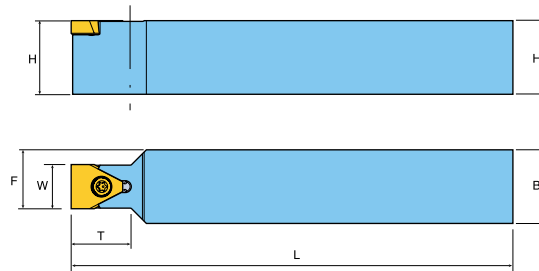

Designation	Dimensions (inch)						Inserts	Screw	Wrench	Torque
	H	B	F	T	L	W				
TTLEN12.7K10	0.500	0.500	0.45	0.79	5.0	0.394	TGUX1004...	TS40B100I	T-15	40
TTLEN15.9K10	0.625	0.625	0.51	0.79	5.0	0.394				
TTLEN19M10	0.750	0.750	0.57	0.79	6.0	0.394				
TTLEN25.4M10	1.000	1.000	0.70	0.79	6.0	0.394				
TTLEN15.9K15	0.625	0.625	0.61	0.79	5.0	0.591	TGUX1504...	TS40B100I	T-15	40
TTLEN19M15	0.750	0.750	0.67	0.79	6.0	0.591				
TTLEN25.4M15	1.000	1.000	0.80	0.79	6.0	0.591	TGUX2006...	TS45120I	T-20	44
TTLEN19K20	0.750	0.750	0.77	1.38	5.0	0.787				
TTLEN25.4M20	1.000	1.000	0.89	1.38	6.0	0.787				
TTLEN31.8P20	1.250	1.250	1.02	1.38	7.0	0.787	TGUX2506...	TS45120I	T-20	44
TTLEN19K25	0.750	0.750	0.87	1.38	5.0	0.984				
TTLEN25.4M25	1.000	1.000	0.99	1.38	6.0	0.984				
TTLEN31.8P25	1.250	1.250	1.12	1.38	7.0	0.984				



GROOVING WITH THE NEW STANDARD HOLDER

- Double ended insert.
- New holder design will accept standard XCMT insert or new XCMT-GV grooving insert.
- Pocket design protects the edge not in use.
- Smooth chip evacuation with thru coolant.
- Economical solution to add even more capability to an existing multifunctional tool.



XCMT GV **New!**

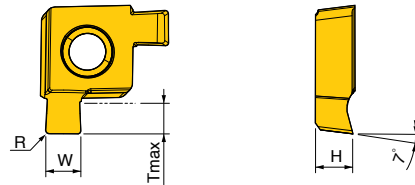

DESIGNATION	Dimensions (Inch)				Grade	TT9080
	W	Tmax	R	H		
XCMT 05R-200020 GV	0.079	0.071	0.008	0.090	•	
XCMT 06R-200020 GV	0.079	0.079	0.008	0.104	•	
XCMT 07R-250020 GV	0.098	0.079	0.008	0.134	•	
XCMT 08R-250020 GV	0.098	0.098	0.008	0.138	•	
XCMT 10R-300030 GV	0.118	0.118	0.012	0.171	•	
XCMT 13R-350030 GV	0.138	0.138	0.012	0.204	•	
XCMT 17R-400040 GV	0.157	0.157	0.016	0.236	•	

XCMT TC



Right hand shown (XCMT 0401)

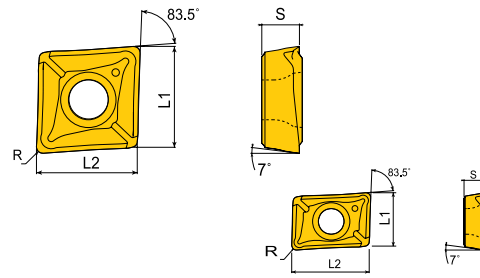

ANSI DESIGNATION	ISO DESIGNATION	Dimensions (Inch)				Grade	TT6030	TT8020	TT9030/ TT9080
		L1	L2	t	R				
XCMT040104LTC	XCMT040104LTC	0.173	0.252	0.067	0.016			•	•
XCMT040104RTC	XCMT040104RTC	0.173	0.252	0.067	0.016			•	•
XCMT050204TC	XCMT050204TC	0.220	0.220	0.083	0.016			•	•
XCMT060204TC	XCMT060204TC	0.252	0.252	0.094	0.016			•	•
XCMT070304TC	XCMT070304TC	0.295	0.295	0.125	0.016			•	•
XCMT080304TC	XCMT080304TC	0.331	0.331	0.125	0.016			•	•
XCMT10T304TC	XCMT10T304TC	0.413	0.413	0.156	0.016	•	•	•	•
XCMT10T308TC	XCMT10T308TC	0.413	0.413	0.156	0.031			•	•
XCMT130404TC	XCMT130404TC	0.528	0.528	0.187	0.016				•
XCMT130408TC	XCMT130408TC	0.528	0.528	0.187	0.031			•	•
XCMT170508TC	XCMT170508TC	0.685	0.685	0.219	0.031			•	•

XCGT TA





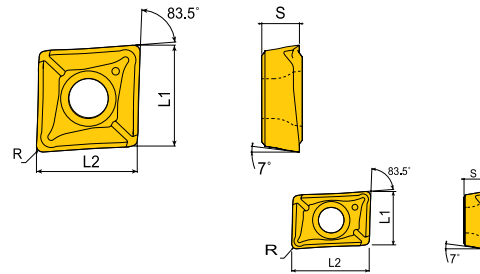

Right hand shown (XCGT 0401)

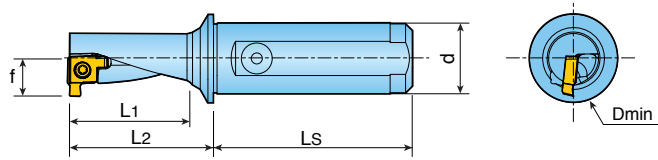

ANSI DESIGNATION	ISO DESIGNATION	Dimensions Inch (mm)				Grade	K10
		L1	L2	t	R		
XCGT040104LTA	XCGT040104LTA	0.252	0.173	0.187	0.016		•
XCGT040104RTA	XCGT040104RTA	0.252	0.173	0.187	0.016		•
XCGT050204TA	XCGT050204TA	0.225	0.220	0.083	0.016		•
XCGT060204TA	XCGT060204TA	0.252	0.252	0.094	0.016		•
XCGT070304TA	XCGT070304TA	0.295	0.295	0.125	0.016		•
XCGT080304TA	XCGT080304TA	0.331	0.331	0.125	0.016		•
XCGT10T304TA	XCGT10T304TA	0.413	0.413	0.156	0.016		•
XCGT130404TA	XCGT130404TA	0.528	0.528	0.187	0.016		•
XCGT170508TA	XCGT170508TA	0.689	0.689	0.219	0.031		•



2.25XD HOLDER

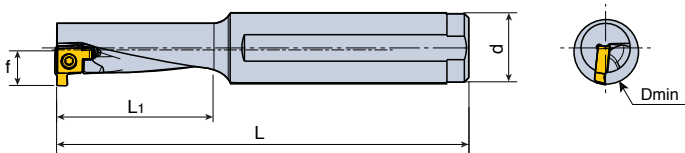

DESIGNATION	f	d	Dimensions (mm)				Dmin				Pipe Thread
			L1	L2	LS						
TCAP 10R/L-2.25DN-IN-GV	.280	.500	.886	1.083	1.654	.472	TS 200381/HG-P	T 6P	XCMT 05R/L200020GV	NPT 1/16	
TCAP 12R/L-2.25DN-IN-GV	.335	.625	1.063	1.299	1.772	.571	TS 220521/HG-P	T 7P	XCMT 06R/L200020GV	NPT 1/8	
TCAP 14R/L-2.25DN-IN-GV	.374	.625	1.240	1.516	1.772	.650	TS 250641/HG-P	T 8P	XCMT 07R/L250020GV	NPT 1/8	
TCAP 16R/L-2.25DN-IN-GV	.437	.750	1.417	1.732	1.968	.748	TS 301001/HG-P	T 9P	XCMT 08R/L250020GV	NPT 1/8	
TCAP 20R/L-2.25DN-IN-GV	.520	1.000	1.772	2.165	2.205	.925	TS 350881/HG-P	T 10P	XCMT 10R/L300030GV	NPT 1/8	
TCAP 25R/L-2.25DN-IN-GV	.650	1.250	2.224	2.716	2.402	1.142	TS 45A1001/HG	T 20	XCMT 13R/L350030GV	NPT 1/8	
TCAP 32R/L-2.25DN-IN-GV	.807	1.500	2.835	3.386	2.913	1.437	TS 45A1001/HG	T 20	XCMT 17R/L400040GV	NPT 1/8	

3.0XD HOLDER



DESIGNATION	f	d	Dimensions (mm)		Dmin				Pipe Thread
			L1	L					
TCAP 10R/L-3.0DN-IN-GV	.280	.500	.886	3.228	.472	TS 200381/HG-P	T 6P	XCMT 05R/L200020GV	NPT 1/16
TCAP 12R/L-3.0DN-IN-GV	.335	.625	1.063	3.740	.571	TS 220521/HG-P	T 7P	XCMT 06R/L200020GV	NPT 1/8
TCAP 14R/L-3.0DN-IN-GV	.374	.625	1.240	3.937	.650	TS 250641/HG-P	T 8P	XCMT 07R/L250020GV	NPT 1/8
TCAP 16R/L-3.0DN-IN-GV	.437	.750	1.417	4.331	.748	TS 301001/HG-P	T 9P	XCMT 08R/L250020GV	NPT 1/8
TCAP 20R/L-3.0DN-IN-GV	.520	1.000	1.772	5.118	.925	TS 350881/HG-P	T 10P	XCMT 10R/L300030GV	NPT 1/8
TCAP 25R/L-3.0DN-IN-GV	.650	1.250	2.224	5.906	1.142	TS 45A1001/HG	T 20	XCMT 13R/L350030GV	NPT 1/8
TCAP 32R/L-3.0DN-IN-GV	.807	1.500	2.835	7.283	1.437	TS 45A1001/HG	T 20	XCMT 17R/L400040GV	NPT 1/8

RECOMMENDED CUTTING CONDITIONS

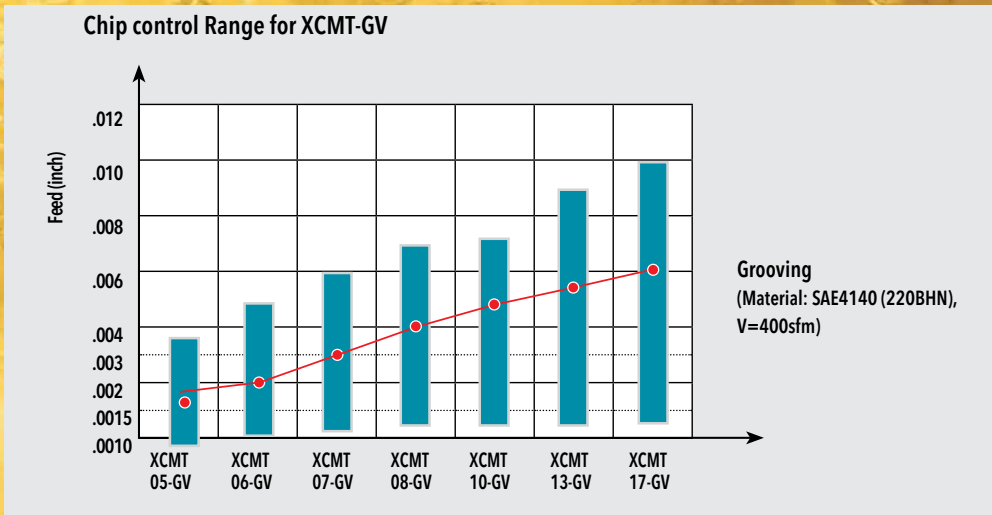

APPLICATION

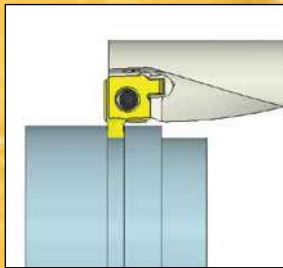

External Groove

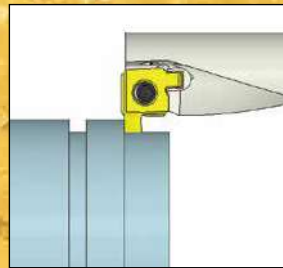

External Turning

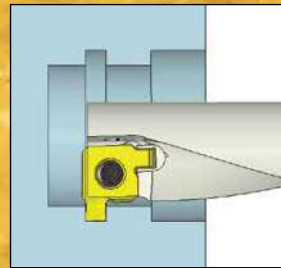

Internal Groove

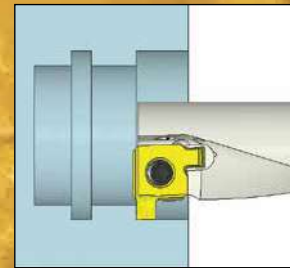

Internal Turning





GOLD RUSH GRADES FOR HOLEMAKING

The ingenious solution that takes cutting tool materials to another level

Features

- Improved adhesion and insert chipping resistance
- Stable and extended tool life in continuous and interrupted cutting operations
- Reduced cutting friction and minimized built-up edge on exotic materials
- High quality surface finish on the work pieces



GOLD RUSH GRADES FOR HOLEMAKING APPLICATIONS

IN1030 (PVD) CAST IRON, STAINLESS, TITANIUM

Great for tough, slower speed applications. A good option when machine rigidity is an issue.

IN2505 (PVD) GENERAL PURPOSE

An improvement over the current IN2005 grade, IN2505 has a multi-layered PVD coating for a wide variety of materials.

IN6505 (CVD) STEEL APPLICATIONS

A 10 μ m thick layer has been added to the CVD coating that enhances toughness and wear resistance. It makes this grade suitable for high speed steel machining.

257

GOLD•TWIST™

REPLACEABLE TIP DRILLS

Ingersoll Cutting Tool Company is proud to announce the expansion of **GOLD•TWIST**: The Next Generation of Replaceable Tip Drills. This new design is a standard product line with tip diameters ranging from .2756" - 1.0197" (7mm ~ 25.9mm) in 0.004" (.1mm) increments and drill bodies available in 1.5xD, 3xD, 5xD and 8xD length to diameter ratios.

The precision bodies have an improved pocket design and innovative clamping system that provide stable performance after multiple tip indexes. These drill bodies also feature twisted coolant holes, polished flutes, and a PVD-coating that allows smooth chip evacuation and prolonged body life. Each body accepts a range of tips that covers .040" (1mm).

The drill tips are offered in grade IN2505 which features a multi-layered PVD coating that provides excellent performance, improved wear resistance and increased tool life in a wide range of applications. With three cutting geometries, the "P" for Steel and General Purpose, the "M" geometry for Stainless Steels and Exotics and the "K" geometry for Irons, we can better meet our customers' needs.

Ingersoll's **GOLD•TWIST** Drilling Line is excellent in higher speed applications, providing guaranteed performance and excellent results in a unique, rigid and fast-indexing clamping system. The result is a product that combines cost efficiency and higher productivity in all your drilling applications.

• Twisted coolant hole with optimum flute design

• Polished flute for smooth chip evacuation

• PVD coated body for prolonged body life

- Innovative quick change system
- New IN2505 grade - Long tool life

• One drill body can cover 5-10 different tip diameters

258

FINE GOLD 2013/2014

DRILL BODY COMPARISON: GOLD TWIST VS. QWIK TWIST

The new Gold Twist pocket design's contact/clamping area is three times deeper than our current Qwik Twist drill.

The accuracy of the added cylinder to the clamping area improves rigidity and helps reduce internal stresses.

The two precision ground positive stop locations improve the drilling tips' position and support.



CYLINDRICAL SHANKS

1.5XD

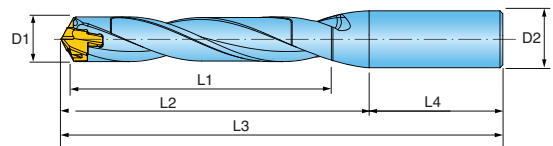

1.5XD	D1 Tip Diameter	D1 Range	L1 DOC	D2 Shank Dia.	D3 Fig Dia.	L2 Ext.	L4 Shank Length	L3 OAL	Pocket Size	Key
TD0700010S4R01	0.2756	0.2913	0.43	0.500	N/A	0.99	1.77	2.760	7	KTD6.0-D9.9
TD0750011S4R01	0.2953	0.3110	0.44	0.500	N/A	1.02	1.77	2.790	7.5	KTD6.0-D9.9
TD0800012S4R01	0.3150	0.3504	0.47	0.500	N/A	1.10	1.77	2.870	8	KTD6.0-D9.9
TD0900013S4R01	0.3543	0.3898	0.55	0.500	N/A	1.15	1.77	2.920	9	KTD6.0-D9.9
TD1000015S6R01	0.3937	0.4291	0.59	0.625	N/A	1.23	1.89	3.120	10	KTD10.0-19.9
TD1100016S6R01	0.4331	0.4685	0.67	0.625	N/A	1.30	1.89	3.190	11	KTD10.0-19.9
TD1200018S6R01	0.4724	0.5079	0.71	0.625	N/A	1.38	1.89	3.270	12	KTD10.0-19.9
TD1300019S6R01	0.5118	0.5472	0.79	0.625	N/A	1.46	1.89	3.350	13	KTD10.0-19.9
TD1400021S6R01	0.5512	0.5866	0.83	0.625	N/A	1.62	1.89	3.510	14	KTD10.0-19.9
TD1500022S7R01	0.5906	0.6260	0.91	0.750	N/A	1.82	1.97	3.790	15	KTD10.0-19.9
TD1600024S7R01	0.6299	0.6654	0.94	0.750	N/A	1.94	1.97	3.910	16	KTD10.0-19.9
TD1700025S7R01	0.6693	0.7047	1.02	0.750	N/A	2.06	1.97	4.030	17	KTD10.0-19.9
TD1800027S1R01	0.7087	0.7441	1.06	1.000	N/A	2.19	2.20	4.390	18	KTD10.0-19.9
TD1900028S1R01	0.7480	0.7835	1.14	1.000	N/A	2.30	2.20	4.500	19	KTD10.0-19.9
TD2000030S1R01	0.7874	0.8228	1.18	1.000	N/A	2.43	2.20	4.630	20	KTD20.0-D26.9
TD2100031S1R01	0.8268	0.8622	1.26	1.000	N/A	2.55	2.20	4.750	21	KTD20.0-D26.9
TD2200033S1R01	0.8661	0.9016	1.30	1.000	N/A	2.67	2.20	4.870	22	KTD20.0-D26.9
TD2300034S9R01	0.9055	0.9409	1.38	1.250	N/A	2.79	2.36	5.150	23	KTD20.0-D26.9
TD2400036S9R01	0.9449	0.9803	1.42	1.250	N/A	2.91	2.36	5.270	24	KTD20.0-D26.9
TD2500037S9R01	0.9843	1.0197	1.50	1.250	N/A	3.03	2.36	5.390	25	KTD20.0-D26.9

CYLINDRICAL SHANKS

3XD

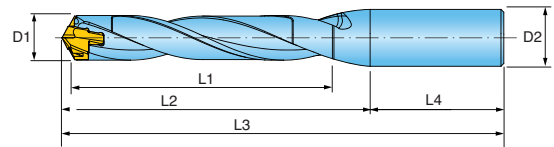

3xD	D1 Tip Diameter Range		L1 DOC	D2 Shank Dia.	D3 Fig Dia.	L2 Ext.	L4 Shank Length	L3 OAL	Pocket Size	Key
TD0700021S4R01	0.2756	0.2913	0.83	0.500	N/A	1.40	1.77	3.170	7	KTD6.0-D9.9
TD0750022S4R01	0.2953	0.3110	0.89	0.500	N/A	1.46	1.77	3.230	7.5	KTD6.0-D9.9
TD0800024S4R01	0.3150	0.3307	0.94	0.500	N/A	1.55	1.77	3.320	8	KTD6.0-D9.9
TD0850025S4R01	0.3346	0.3504	1.00	0.500	N/A	1.61	1.77	3.380	8.5	KTD6.0-D9.9
TD0900027S4R01	0.3543	0.3701	1.06	0.500	N/A	1.69	1.77	3.460	9	KTD6.0-D9.9
TD0950028S4R01	0.3740	0.3898	1.12	0.500	N/A	1.74	1.77	3.510	9.5	KTD6.0-D9.9
TD1000030S6R01	0.3937	0.4094	1.18	0.625	N/A	1.82	1.89	3.710	10	KTD10.0-19.9
TD1050031S6R01	0.4134	0.4291	1.26	0.625	N/A	1.88	1.89	3.770	10.5	KTD10.0-19.9
TD1100033S6R01	0.4331	0.4488	1.30	0.625	N/A	1.95	1.89	3.840	11	KTD10.0-19.9
TD1150034S6R01	0.4528	0.4685	1.38	0.625	N/A	2.01	1.89	3.900	11.5	KTD10.0-19.9
TD1200036S6R01	0.4724	0.4882	1.42	0.625	N/A	2.09	1.89	3.980	12	KTD10.0-19.9
TD1250037S6R01	0.4921	0.5079	1.46	0.625	N/A	2.15	1.89	4.040	12.5	KTD10.0-19.9
TD1300039S6R01	0.5118	0.5276	1.54	0.625	N/A	2.23	1.89	4.120	13	KTD10.0-19.9
TD1350040S6R01	0.5315	0.5472	1.61	0.625	N/A	2.29	1.89	4.180	13.5	KTD10.0-19.9
TD1400042S6R01	0.5512	0.5669	1.65	0.625	N/A	2.44	1.89	4.330	14	KTD10.0-19.9
TD1450043S6R01	0.5709	0.5866	1.73	0.625	N/A	2.50	1.89	4.390	14.5	KTD10.0-19.9
TD1500045S7R01	0.5906	0.6260	1.77	0.750	N/A	2.70	1.97	4.670	15	KTD10.0-19.9
TD1600048S7R01	0.6299	0.6654	1.89	0.750	N/A	2.89	1.97	4.860	16	KTD10.0-19.9
TD1700051S7R01	0.6693	0.7047	2.01	0.750	N/A	3.07	1.97	5.040	17	KTD10.0-19.9
TD1800054S1R01	0.7087	0.7441	2.13	1.000	N/A	3.25	2.20	5.450	18	KTD10.0-19.9
TD1900057S1R01	0.7480	0.7835	2.24	1.000	N/A	3.43	2.20	5.630	19	KTD10.0-19.9
TD2000060S1R01	0.7874	0.8228	2.36	1.000	N/A	3.61	2.20	5.810	20	KTD20.0-D26.9
TD2100063S1R01	0.8268	0.8622	2.48	1.000	N/A	3.79	2.20	5.990	21	KTD20.0-D26.9
TD2200066S1R01	0.8661	0.9016	2.60	1.000	N/A	3.97	2.20	6.170	22	KTD20.0-D26.9
TD2300069S9R01	0.9055	0.9409	2.72	1.250	N/A	4.15	2.36	6.510	23	KTD20.0-D26.9
TD2400072S9R01	0.9449	0.9803	2.83	1.250	N/A	4.33	2.36	6.690	24	KTD20.0-D26.9
TD2500075S9R01	0.9843	1.0197	2.95	1.250	N/A	4.51	2.36	6.870	25	KTD20.0-D26.9

CYLINDRICAL SHANKS

5XD

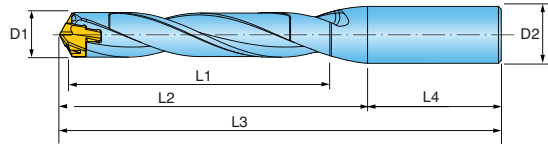

5xD	D1 Tip Diameter Range		L1 DOC	D2 Shank Dia.	D3 Fig Dia.	L2 Ext.	L4 Shank Length	L3 OAL	Pocket Size	Key
TD0700035S4R01	0.2756	0.2913	1.38	0.500	N/A	1.95	1.77	3.720	7	KTD6.0-D9.9
TD0750037S4R01	0.2953	0.3110	1.48	0.500	N/A	2.05	1.77	3.820	7.5	KTD6.0-D9.9
TD0800040S4R01	0.3150	0.3307	1.57	0.500	N/A	2.18	1.77	3.950	8	KTD6.0-D9.9
TD0850042S4R01	0.3346	0.3504	1.67	0.500	N/A	2.28	1.77	4.050	8.5	KTD6.0-D9.9
TD0900045S4R01	0.3543	0.3701	1.77	0.500	N/A	2.39	1.77	4.160	9	KTD6.0-D9.9
TD0950047S4R01	0.3740	0.3898	1.87	0.500	N/A	2.49	1.77	4.260	9.5	KTD6.0-D9.9
TD1000050S6R01	0.3937	0.4094	1.97	0.625	N/A	2.61	1.89	4.500	10	KTD10.0-19.9
TD1050052S6R01	0.4134	0.4291	2.09	0.625	N/A	2.70	1.89	4.590	10.5	KTD10.0-19.9
TD1100055S6R01	0.4331	0.4488	2.17	0.625	N/A	2.82	1.89	4.710	11	KTD10.0-19.9
TD1150057S6R01	0.4528	0.4685	2.28	0.625	N/A	2.92	1.89	4.810	11.5	KTD10.0-19.9
TD1200060S6R01	0.4724	0.4882	2.36	0.625	N/A	3.03	1.89	4.920	12	KTD10.0-19.9
TD1250062S6R01	0.4921	0.5079	2.44	0.625	N/A	3.13	1.89	5.020	12.5	KTD10.0-19.9
TD1300065S6R01	0.5118	0.5276	2.56	0.625	N/A	3.25	1.89	5.140	13	KTD10.0-19.9
TD1350067S6R01	0.5315	0.5472	2.68	0.625	N/A	3.35	1.89	5.240	13.5	KTD10.0-19.9
TD1400070S6R01	0.5512	0.5669	2.76	0.625	N/A	3.55	1.89	5.440	14	KTD10.0-19.9
TD1450072S6R01	0.5709	0.5866	2.87	0.625	N/A	3.65	1.89	5.540	14.5	KTD10.0-19.9
TD1500075S7R01	0.5906	0.6260	2.95	0.750	N/A	3.89	1.97	5.860	15	KTD10.0-19.9
TD1600080S7R01	0.6299	0.6654	3.15	0.750	N/A	4.15	1.97	6.120	16	KTD10.0-19.9
TD1700085S7R01	0.6693	0.7047	3.35	0.750	N/A	4.41	1.97	6.380	17	KTD10.0-19.9
TD1800090S1R01	0.7087	0.7441	3.54	1.000	N/A	4.67	2.20	6.870	18	KTD10.0-19.9
TD1900095S1R01	0.7480	0.7835	3.74	1.000	N/A	4.92	2.20	7.120	19	KTD10.0-19.9
TD2000100S1R01	0.7874	0.8228	3.94	1.000	N/A	5.18	2.20	7.380	20	KTD20.0-D26.9
TD2100105S1R01	0.8268	0.8622	4.13	1.000	N/A	5.44	2.20	7.640	21	KTD20.0-D26.9
TD2200110S1R01	0.8661	0.9016	4.33	1.000	N/A	5.70	2.20	7.900	22	KTD20.0-D26.9
TD2300115S9R01	0.9055	0.9409	4.53	1.250	N/A	5.96	2.36	8.320	23	KTD20.0-D26.9
TD2400120S9R01	0.9449	0.9803	4.72	1.250	N/A	6.22	2.36	8.580	24	KTD20.0-D26.9
TD2500125S9R01	0.9843	1.0197	4.92	1.250	N/A	6.48	2.36	8.840	25	KTD20.0-D26.9

CYLINDRICAL SHANKS

8XD



NOTE: We strongly recommend the use of a 1.5:1 or 3:1 Gold•Twist drill of the same diameter to drill a centering starter hole. The use of a centering starter hole improves hole location, accuracy, roundness, straightness and surface finish.

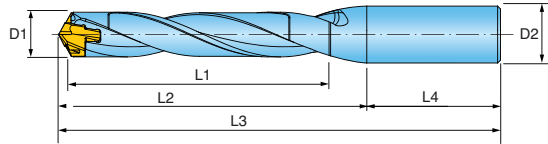

8xD	D1 Tip Diameter Range		L1 DOC	D2 Shank Dia.	D3 Fig Dia.	L2 Ext.	L4 Shank Length	L3 OAL	Pocket Size	Key
TD0700056S4R01	0.2756	0.2913	2.20	0.500	N/A	2.78	1.77	4.550	7	KTD6.0-D9.9
TD0750060S4R01	0.2953	0.3110	2.28	0.500	N/A	2.94	1.77	4.710	7.5	KTD6.0-D9.9
TD0800064S4R01	0.3150	0.3307	2.52	0.500	N/A	3.13	1.77	4.900	8	KTD6.0-D9.9
TD0850068S4R01	0.3346	0.3504	2.68	0.500	N/A	3.32	1.77	5.090	8.5	KTD6.0-D9.9
TD0900072S4R01	0.3543	0.3701	2.83	0.500	N/A	3.46	1.77	5.230	9	KTD6.0-D9.9
TD0950076S4R01	0.3740	0.3898	2.99	0.500	N/A	3.65	1.77	5.420	9.5	KTD6.0-D9.9
TD1000080S6R01	0.3937	0.4094	3.15	0.625	N/A	3.79	1.89	5.680	10	KTD10.0-19.9
TD1050084S6R01	0.4134	0.4291	3.31	0.625	N/A	3.94	1.89	5.830	10.5	KTD10.0-19.9
TD1100088S6R01	0.4331	0.4488	3.46	0.625	N/A	4.12	1.89	6.010	11	KTD10.0-19.9
TD1150092S6R01	0.4528	0.4685	3.62	0.625	N/A	4.28	1.89	6.170	11.5	KTD10.0-19.9
TD1200096S6R01	0.4724	0.4882	3.78	0.625	N/A	4.45	1.89	6.340	12	KTD10.0-19.9
TD1250100S6R01	0.4921	0.5079	3.94	0.625	N/A	4.61	1.89	6.500	12.5	KTD10.0-19.9
TD1300104S6R01	0.5118	0.5276	4.09	0.625	N/A	4.79	1.89	6.680	13	KTD10.0-19.9
TD1350108S6R01	0.5315	0.5472	4.25	0.625	N/A	4.94	1.89	6.830	13.5	KTD10.0-19.9
TD1400112S6R01	0.5512	0.5669	4.41	0.625	N/A	5.20	1.89	7.090	14	KTD10.0-19.9
TD1450116S6R01	0.5709	0.5866	4.57	0.625	N/A	5.36	1.89	7.250	14.5	KTD10.0-19.9
TD1500120S7R01	0.5906	0.6260	4.72	0.750	N/A	5.66	1.97	7.630	15	KTD10.0-19.9
TD1600128S7R01	0.6299	0.6654	5.04	0.750	N/A	6.04	1.97	8.010	16	KTD10.0-19.9
TD1700136S7R01	0.6693	0.7047	5.35	0.750	N/A	6.41	1.97	8.380	17	KTD10.0-19.9
TD1800144S1R01	0.7087	0.7441	5.67	1.000	N/A	6.79	2.20	8.990	18	KTD10.0-19.9
TD1900152S1R01	0.7480	0.7835	5.98	1.000	N/A	7.17	2.20	9.370	19	KTD10.0-19.9
TD2000160S1R01	0.7874	0.8228	6.30	1.000	N/A	7.54	2.20	9.740	20	KTD20.0-D26.9
TD2100168S1R01	0.8268	0.8622	6.61	1.000	N/A	7.92	2.20	10.120	21	KTD20.0-D26.9
TD2200176S1R01	0.8661	0.9016	6.93	1.000	N/A	8.30	2.20	10.500	22	KTD20.0-D26.9
TD2300184S9R01	0.9055	0.9409	7.24	1.250	N/A	8.68	2.36	11.040	23	KTD20.0-D26.9
TD2400192S9R01	0.9449	0.9803	7.56	1.250	N/A	9.06	2.36	11.420	24	KTD20.0-D26.9
TD2500200S9R01	0.9843	1.0197	7.87	1.250	N/A	9.43	2.36	11.790	25	KTD20.0-D26.9

WELDON & ISO9766 SHANKS

1.5xD

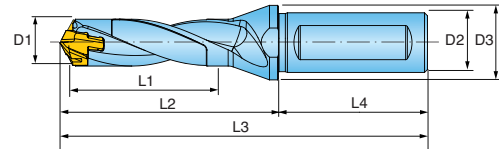

1.5xD	D1 Tip Diameter Range		L1 DOC	D2 Shank Dia.	D3 Fig Dia.	L2 Ext.	L4 Shank Length	L3 OAL	Pocket Size	Key
TD0700010B9R01	0.2756	0.2913	0.43	0.500	0.63	0.99	1.77	2.760	7	KTD6.0-D9.9
TD0750011B9R01	0.2953	0.3110	0.44	0.500	0.63	1.02	1.77	2.790	7.5	KTD6.0-D9.9
TD0800012B9R01	0.3150	0.3504	0.47	0.500	0.63	1.10	1.77	2.870	8	KTD6.0-D9.9
TD0900013B9R01	0.3543	0.3898	0.55	0.500	0.63	1.15	1.77	2.920	9	KTD6.0-D9.9
TD1000015C0R01	0.3937	0.4291	0.59	0.625	0.79	1.23	1.89	3.120	10	KTD10.0-19.9
TD1100016C0R01	0.4331	0.4685	0.67	0.625	0.79	1.30	1.89	3.190	11	KTD10.0-19.9
TD1200018C0R01	0.4724	0.5079	0.71	0.625	0.79	1.38	1.89	3.270	12	KTD10.0-19.9
TD1300019C0R01	0.5118	0.5472	0.79	0.625	0.79	1.46	1.89	3.350	13	KTD10.0-19.9
TD1400021C0R01	0.5512	0.5866	0.83	0.625	0.79	1.62	1.89	3.510	14	KTD10.0-19.9
TD150002218R01	0.5906	0.6260	0.91	0.750	0.98	1.82	1.97	3.790	15	KTD10.0-19.9
TD160002418R01	0.6299	0.6654	0.94	0.750	0.98	1.94	1.97	3.910	16	KTD10.0-19.9
TD170002518R01	0.6693	0.7047	1.02	0.750	0.98	2.06	1.97	4.030	17	KTD10.0-19.9
TD1800027C8R01	0.7087	0.7441	1.06	1.000	1.26	2.19	2.20	4.390	18	KTD10.0-19.9
TD1900028C8R01	0.7480	0.7835	1.14	1.000	1.26	2.30	2.20	4.500	19	KTD10.0-19.9
TD2000030C8R01	0.7874	0.8228	1.18	1.000	1.26	2.43	2.20	4.630	20	KTD20.0-D26.9
TD2100031C8R01	0.8268	0.8622	1.26	1.000	1.26	2.55	2.20	4.750	21	KTD20.0-D26.9
TD2200033C8R01	0.8661	0.9016	1.30	1.000	1.26	2.67	2.20	4.870	22	KTD20.0-D26.9
TD2300034B7R01	0.9055	0.9409	1.38	1.250	1.65	2.79	2.36	5.150	23	KTD20.0-D26.9
TD2400036B7R01	0.9449	0.9803	1.42	1.250	1.65	2.91	2.36	5.270	24	KTD20.0-D26.9
TD2500037B7R01	0.9843	1.0197	1.50	1.250	1.65	3.03	2.36	5.390	25	KTD20.0-D26.9

WELDON & ISO9766 SHANKS

3XD

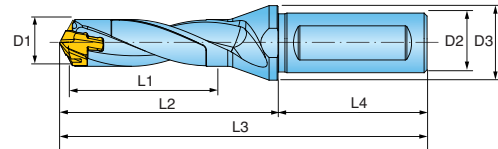

3xD	D1 Tip Diameter Range		L1 DOC	D2 Shank Dia.	D3 Fig Dia.	L2 Ext.	L4 Shank Length	L3 OAL	Pocket Size	Key
TD0700021B9R01	0.2756	0.2913	0.83	0.500	0.63	1.40	1.77	3.170	7	KTD6.0-D9.9
TD0750022B9R01	0.2953	0.3110	0.89	0.500	0.63	1.46	1.77	3.230	7.5	KTD6.0-D9.9
TD0800024B9R01	0.3150	0.3307	0.94	0.500	0.63	1.55	1.77	3.320	8	KTD6.0-D9.9
TD0850025B9R01	0.3346	0.3504	1.00	0.500	0.63	1.61	1.77	3.380	8.5	KTD6.0-D9.9
TD0900027B9R01	0.3543	0.3701	1.06	0.500	0.63	1.69	1.77	3.460	9	KTD6.0-D9.9
TD0950028B9R01	0.3740	0.3898	1.12	0.500	0.63	1.74	1.77	3.510	9.5	KTD6.0-D9.9
TD1000030C0R01	0.3937	0.4094	1.18	0.625	0.79	1.82	1.89	3.710	10	KTD10.0-19.9
TD1050031C0R01	0.4134	0.4291	1.26	0.625	0.79	1.88	1.89	3.770	10.5	KTD10.0-19.9
TD1100033C0R01	0.4331	0.4488	1.30	0.625	0.79	1.95	1.89	3.840	11	KTD10.0-19.9
TD1150034C0R01	0.4528	0.4685	1.38	0.625	0.79	2.01	1.89	3.900	11.5	KTD10.0-19.9
TD1200036C0R01	0.4724	0.4882	1.42	0.625	0.79	2.09	1.89	3.980	12	KTD10.0-19.9
TD1250037C0R01	0.4921	0.5079	1.46	0.625	0.79	2.15	1.89	4.040	12.5	KTD10.0-19.9
TD1300039C0R01	0.5118	0.5276	1.54	0.625	0.79	2.23	1.89	4.120	13	KTD10.0-19.9
TD1350040C0R01	0.5315	0.5472	1.61	0.625	0.79	2.29	1.89	4.180	13.5	KTD10.0-19.9
TD1400042C0R01	0.5512	0.5669	1.65	0.625	0.79	2.44	1.89	4.330	14	KTD10.0-19.9
TD1450043C0R01	0.5709	0.5866	1.73	0.625	0.79	2.50	1.89	4.390	14.5	KTD10.0-19.9
TD150004518R01	0.5906	0.6260	1.77	0.750	0.98	2.70	1.97	4.670	15	KTD10.0-19.9
TD160004818R01	0.6299	0.6654	1.89	0.750	0.98	2.89	1.97	4.860	16	KTD10.0-19.9
TD170005118R01	0.6693	0.7047	2.01	0.750	0.98	3.07	1.97	5.040	17	KTD10.0-19.9
TD1800054C8R01	0.7087	0.7441	2.13	1.000	1.26	3.25	2.20	5.450	18	KTD10.0-19.9
TD1900057C8R01	0.7480	0.7835	2.24	1.000	1.26	3.43	2.20	5.630	19	KTD10.0-19.9
TD2000060C8R01	0.7874	0.8228	2.36	1.000	1.26	3.61	2.20	5.810	20	KTD20.0-D26.9
TD2100063C8R01	0.8268	0.8622	2.48	1.000	1.26	3.79	2.20	5.990	21	KTD20.0-D26.9
TD2200066C8R01	0.8661	0.9016	2.60	1.000	1.26	3.97	2.20	6.170	22	KTD20.0-D26.9
TD2300069B7R01	0.9055	0.9409	2.72	1.250	1.65	4.15	2.36	6.510	23	KTD20.0-D26.9
TD2400072B7R01	0.9449	0.9803	2.83	1.250	1.65	4.33	2.36	6.690	24	KTD20.0-D26.9
TD2500075B7R01	0.9843	1.0197	2.95	1.250	1.65	4.51	2.36	6.870	25	KTD20.0-D26.9

WELDON & ISO9766 SHANKS

5XD



Coolant

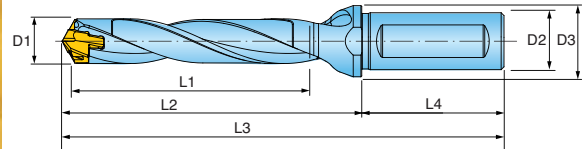

5xD	D1 Tip Diameter Range		L1 DOC	D2 Shank Dia.	D3 Fig Dia.	L2 Ext.	L4 Shank Length	L3 OAL	Pocket Size	Key
TD0700035B9R01	0.2756	0.2913	1.38	0.500	0.63	1.95	1.77	3.720	7	KTD6.0-D9.9
TD0750037B9R01	0.2953	0.3110	1.48	0.500	0.63	2.05	1.77	3.820	7.5	KTD6.0-D9.9
TD0800040B9R01	0.3150	0.3307	1.57	0.500	0.63	2.18	1.77	3.950	8	KTD6.0-D9.9
TD0850042B9R01	0.3346	0.3504	1.67	0.500	0.63	2.28	1.77	4.050	8.5	KTD6.0-D9.9
TD0900045B9R01	0.3543	0.3701	1.77	0.500	0.63	2.39	1.77	4.160	9	KTD6.0-D9.9
TD0950047B9R01	0.3740	0.3898	1.87	0.500	0.63	2.49	1.77	4.260	9.5	KTD6.0-D9.9
TD1000050C0R01	0.3937	0.4094	1.97	0.625	0.79	2.61	1.89	4.500	10	KTD10.0-19.9
TD1050052C0R01	0.4134	0.4291	2.09	0.625	0.79	2.70	1.89	4.590	10.5	KTD10.0-19.9
TD1100055C0R01	0.4331	0.4488	2.17	0.625	0.79	2.82	1.89	4.710	11	KTD10.0-19.9
TD1150057C0R01	0.4528	0.4685	2.28	0.625	0.79	2.92	1.89	4.810	11.5	KTD10.0-19.9
TD1200060C0R01	0.4724	0.4882	2.36	0.625	0.79	3.03	1.89	4.920	12	KTD10.0-19.9
TD1250062C0R01	0.4921	0.5079	2.44	0.625	0.79	3.13	1.89	5.020	12.5	KTD10.0-19.9
TD1300065C0R01	0.5118	0.5276	2.56	0.625	0.79	3.25	1.89	5.140	13	KTD10.0-19.9
TD1350067C0R01	0.5315	0.5472	2.68	0.625	0.79	3.35	1.89	5.240	13.5	KTD10.0-19.9
TD1400070C0R01	0.5512	0.5669	2.76	0.625	0.79	3.55	1.89	5.440	14	KTD10.0-19.9
TD1450072C0R01	0.5709	0.5866	2.87	0.625	0.79	3.65	1.89	5.540	14.5	KTD10.0-19.9
TD150007518R01	0.5906	0.6260	2.95	0.750	0.98	3.89	1.97	5.860	15	KTD10.0-19.9
TD160008018R01	0.6299	0.6654	3.15	0.750	0.98	4.15	1.97	6.120	16	KTD10.0-19.9
TD170008518R01	0.6693	0.7047	3.35	0.750	0.98	4.41	1.97	6.380	17	KTD10.0-19.9
TD1800090C8R01	0.7087	0.7441	3.54	1.000	1.26	4.67	2.20	6.870	18	KTD10.0-19.9
TD1900095C8R01	0.7480	0.7835	3.74	1.000	1.26	4.92	2.20	7.120	19	KTD10.0-19.9
TD2000100C8R01	0.7874	0.8228	3.94	1.000	1.26	5.18	2.20	7.380	20	KTD20.0-D26.9
TD2100105C8R01	0.8268	0.8622	4.13	1.000	1.26	5.44	2.20	7.640	21	KTD20.0-D26.9
TD2200110C8R01	0.8661	0.9016	4.33	1.000	1.26	5.70	2.20	7.900	22	KTD20.0-D26.9
TD2300115B7R01	0.9055	0.9409	4.53	1.250	1.65	5.96	2.36	8.320	23	KTD20.0-D26.9
TD2400120B7R01	0.9449	0.9803	4.72	1.250	1.65	6.22	2.36	8.580	24	KTD20.0-D26.9
TD2500125B7R01	0.9843	1.0197	4.92	1.250	1.65	6.48	2.36	8.840	25	KTD20.0-D26.9

WELDON & ISO9766 SHANKS

8XD



NOTE: We strongly recommend the use of a 1.5:1 or 3:1 Gold•Twist drill of the same diameter to drill a centering starter hole. The use of a centering starter hole improves hole location, accuracy, roundness, straightness and surface finish.

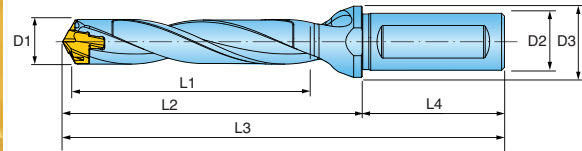

8xD	D1 Tip Diameter Range		L1 DOC	D2 Shank Dia.	D3 Fig Dia.	L2 Ext.	L4 Shank Length	L3 OAL	Pocket Size	Key
TD0700056B9R01	0.2756	0.2913	0.43	0.500	0.63	0.99	1.77	2.760	7	KTD6.0-D9.9
TD0750060B9R01	0.2953	0.3110	2.28	0.500	0.63	2.94	1.77	4.710	7.5	KTD6.0-D9.9
TD0800064B9R01	0.3150	0.3307	2.52	0.500	0.63	3.13	1.77	4.900	8	KTD6.0-D9.9
TD0850068B9R01	0.3346	0.3504	2.68	0.500	0.63	3.32	1.77	5.090	8.5	KTD6.0-D9.9
TD0900072B9R01	0.3543	0.3701	2.83	0.500	0.63	3.46	1.77	5.230	9	KTD6.0-D9.9
TD0950076B9R01	0.3740	0.3898	2.99	0.500	0.63	3.65	1.77	5.420	9.5	KTD6.0-D9.9
TD1000080C0R01	0.3937	0.4094	3.15	0.625	0.79	3.79	1.89	5.680	10	KTD10.0-19.9
TD1050084C0R01	0.4134	0.4291	3.31	0.625	0.79	3.94	1.89	5.830	10.5	KTD10.0-19.9
TD1100088C0R01	0.4331	0.4488	3.46	0.625	0.79	4.12	1.89	6.010	11	KTD10.0-19.9
TD1150092C0R01	0.4528	0.4685	3.62	0.625	0.79	4.28	1.89	6.170	11.5	KTD10.0-19.9
TD1200096C0R01	0.4724	0.4882	3.78	0.625	0.79	4.45	1.89	6.340	12	KTD10.0-19.9
TD1250100C0R01	0.4921	0.5079	3.94	0.625	0.79	4.61	1.89	6.500	12.5	KTD10.0-19.9
TD1300104C0R01	0.5118	0.5276	4.09	0.625	0.79	4.79	1.89	6.680	13	KTD10.0-19.9
TD1350108C0R01	0.5315	0.5472	4.25	0.625	0.79	4.94	1.89	6.830	13.5	KTD10.0-19.9
TD1400112C0R01	0.5512	0.5669	4.41	0.625	0.79	5.20	1.89	7.090	14	KTD10.0-19.9
TD1450116C0R01	0.5709	0.5866	4.57	0.625	0.79	5.36	1.89	7.250	14.5	KTD10.0-19.9
TD150012018R01	0.5906	0.6260	4.72	0.750	0.98	5.66	1.97	7.630	15	KTD10.0-19.9
TD160012818R01	0.6299	0.6654	5.04	0.750	0.98	6.04	1.97	8.010	16	KTD10.0-19.9
TD170013618R01	0.6693	0.7047	5.35	0.750	0.98	6.41	1.97	8.380	17	KTD10.0-19.9
TD1800144C8R01	0.7087	0.7441	5.67	1.000	1.26	6.79	2.20	8.990	18	KTD10.0-19.9
TD1900152C8R01	0.7480	0.7835	5.98	1.000	1.26	7.17	2.20	9.370	19	KTD10.0-19.9
TD2000160C8R01	0.7874	0.8228	6.30	1.000	1.26	7.54	2.20	9.740	20	KTD20.0-D26.9
TD2100168C8R01	0.8268	0.8622	6.61	1.000	1.26	7.92	2.20	10.120	21	KTD20.0-D26.9
TD2200176C8R01	0.8661	0.9016	6.93	1.000	1.26	8.30	2.20	10.500	22	KTD20.0-D26.9
TD2300184B7R01	0.9055	0.9409	7.24	1.250	1.65	8.68	2.36	11.040	23	KTD20.0-D26.9
TD2400192B7R01	0.9449	0.9803	7.56	1.250	1.65	9.06	2.36	11.420	24	KTD20.0-D26.9
TD2500200B7R01	0.9843	1.0197	7.87	1.250	1.65	9.43	2.36	11.790	25	KTD20.0-D26.9

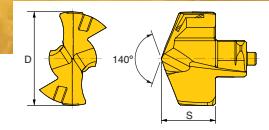

TIPS

"P" Geometry Steel	"M" Geometry Stainless Steel	"K" Geometry Cast Iron	(D) Diameter		S Dim (inch)	Pocket Size	Grade
			(mm)	(inch)			
TPA0700R01	TMA0700R01	TKA0700R01	7.0	0.2756	0.181	7	IN2505
TPA0710R01	TMA0710R01	TKA0710R01	7.1	0.2795	0.181	7	IN2505
TPA0720R01	TMA0720R01	TKA0720R01	7.2	0.2835	0.181	7	IN2505
TPA0730R01	TMA0730R01	TKA0730R01	7.3	0.2874	0.181	7	IN2505
TPA0740R01	TMA0740R01	TKA0740R01	7.4	0.2913	0.181	7	IN2505
TPA0750R01	TMA0750R01	TKA0750R01	7.5	0.2953	0.181	7.5	IN2505
TPA0760R01	TMA0760R01	TKA0760R01	7.6	0.2992	0.181	7.5	IN2505
TPA0770R01	TMA0770R01	TKA0770R01	7.7	0.3031	0.181	7.5	IN2505
TPA0780R01	TMA0780R01	TKA0780R01	7.8	0.3071	0.181	7.5	IN2505
TPA0790R01	TMA0790R01	TKA0790R01	7.9	0.3110	0.181	7.5	IN2505
TPA0800R01	TMA0800R01	TKA0800R01	8.0	0.3150	0.213	8	IN2505
TPA0810R01	TMA0810R01	TKA0810R01	8.1	0.3189	0.213	8	IN2505
TPA0820R01	TMA0820R01	TKA0820R01	8.2	0.3228	0.213	8	IN2505
TPA0830R01	TMA0830R01	TKA0830R01	8.3	0.3268	0.213	8	IN2505
TPA0840R01	TMA0840R01	TKA0840R01	8.4	0.3307	0.213	8	IN2505
TPA0850R01	TMA0850R01	TKA0850R01	8.5	0.3346	0.213	8.5	IN2505
TPA0860R01	TMA0860R01	TKA0860R01	8.6	0.3386	0.213	8.5	IN2505
TPA0870R01	TMA0870R01	TKA0870R01	8.7	0.3425	0.213	8.5	IN2505
TPA0880R01	TMA0880R01	TKA0880R01	8.8	0.3465	0.213	8.5	IN2505
TPA0890R01	TMA0890R01	TKA0890R01	8.9	0.3504	0.213	8.5	IN2505
TPA0900R01	TMA0900R01	TKA0900R01	9.0	0.3543	0.228	9	IN2505
TPA0910R01	TMA0910R01	TKA0910R01	9.1	0.3583	0.228	9	IN2505
TPA0920R01	TMA0920R01	TKA0920R01	9.2	0.3622	0.228	9	IN2505
TPA0930R01	TMA0930R01	TKA0930R01	9.3	0.3661	0.228	9	IN2505
TPA0940R01	TMA0940R01	TKA0940R01	9.4	0.3701	0.228	9	IN2505
TPA0950R01	TMA0950R01	TKA0950R01	9.5	0.3740	0.228	9.5	IN2505
TPA0960R01	TMA0960R01	TKA0960R01	9.6	0.3780	0.228	9.5	IN2505
TPA0970R01	TMA0970R01	TKA0970R01	9.7	0.3819	0.228	9.5	IN2505
TPA0980R01	TMA0980R01	TKA0980R01	9.8	0.3858	0.228	9.5	IN2505
TPA0990R01	TMA0990R01	TKA0990R01	9.9	0.3898	0.228	9.5	IN2505
TPA1000R01	TMA1000R01	TKA1000R01	10.0	0.3937	0.244	10	IN2505
TPA1010R01	TMA1010R01	TKA1010R01	10.1	0.3976	0.244	10	IN2505
TPA1020R01	TMA1020R01	TKA1020R01	10.2	0.4016	0.244	10	IN2505
TPA1030R01	TMA1030R01	TKA1030R01	10.3	0.4055	0.244	10	IN2505
TPA1040R01	TMA1040R01	TKA1040R01	10.4	0.4094	0.244	10	IN2505
TPA1050R01	TMA1050R01	TKA1050R01	10.5	0.4134	0.244	10.5	IN2505
TPA1060R01	TMA1060R01	TKA1060R01	10.6	0.4173	0.244	10.5	IN2505
TPA1070R01	TMA1070R01	TKA1070R01	10.7	0.4213	0.244	10.5	IN2505
TPA1080R01	TMA1080R01	TKA1080R01	10.8	0.4252	0.244	10.5	IN2505
TPA1090R01	TMA1090R01	TKA1090R01	10.9	0.4291	0.244	10.5	IN2505
TPA1100R01	TMA1100R01	TKA1100R01	11.0	0.4331	0.260	11	IN2505
TPA1110R01	TMA1110R01	TKA1110R01	11.1	0.4370	0.260	11	IN2505
TPA1120R01	TMA1120R01	TKA1120R01	11.2	0.4409	0.260	11	IN2505
TPA1130R01	TMA1130R01	TKA1130R01	11.3	0.4449	0.260	11	IN2505
TPA1140R01	TMA1140R01	TKA1140R01	11.4	0.4488	0.260	11	IN2505
TPA1150R01	TMA1150R01	TKA1150R01	11.5	0.4528	0.260	11.5	IN2505
TPA1160R01	TMA1160R01	TKA1160R01	11.6	0.4567	0.260	11.5	IN2505
TPA1170R01	TMA1170R01	TKA1170R01	11.7	0.4606	0.260	11.5	IN2505
TPA1180R01	TMA1180R01	TKA1180R01	11.8	0.4646	0.260	11.5	IN2505
TPA1190R01	TMA1190R01	TKA1190R01	11.9	0.4685	0.260	11.5	IN2505
TPA1200R01	TMA1200R01	TKA1200R01	12.0	0.4724	0.275	12	IN2505
TPA1210R01	TMA1210R01	TKA1210R01	12.1	0.4764	0.275	12	IN2505
TPA1220R01	TMA1220R01	TKA1220R01	12.2	0.4803	0.275	12	IN2505

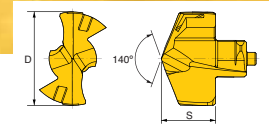

TIPS

"P" Geometry Steel	"M" Geometry Stainless Steel	"K" Geometry Cast Iron	(D) Diameter		S Dim (inch)	Pocket Size	Grade
			(mm)	(inch)			
TPA1230R01	TMA1230R01	TKA1230R01	12.3	0.4843	0.275	12	IN2505
TPA1240R01	TMA1240R01	TKA1240R01	12.4	0.4882	0.275	12	IN2505
TPA1250R01	TMA1250R01	TKA1250R01	12.5	0.4921	0.275	12.5	IN2505
TPA1260R01	TMA1260R01	TKA1260R01	12.6	0.4961	0.275	12.5	IN2505
TPA1270R01	TMA1270R01	TKA1270R01	12.7	0.5000	0.275	12.5	IN2505
TPA1280R01	TMA1280R01	TKA1280R01	12.8	0.5039	0.275	12.5	IN2505
TPA1290R01	TMA1290R01	TKA1290R01	12.9	0.5079	0.275	12.5	IN2505
TPA1300R01	TMA1300R01	TKA1300R01	13.0	0.5118	0.299	13	IN2505
TPA1310R01	TMA1310R01	TKA1310R01	13.1	0.5157	0.299	13	IN2505
TPA1320R01	TMA1320R01	TKA1320R01	13.2	0.5197	0.299	13	IN2505
TPA1330R01	TMA1330R01	TKA1330R01	13.3	0.5236	0.299	13	IN2505
TPA1340R01	TMA1340R01	TKA1340R01	13.4	0.5276	0.299	13	IN2505
TPA1350R01	TMA1350R01	TKA1350R01	13.5	0.5315	0.299	13.5	IN2505
TPA1360R01	TMA1360R01	TKA1360R01	13.6	0.5354	0.299	13.5	IN2505
TPA1370R01	TMA1370R01	TKA1370R01	13.7	0.5394	0.299	13.5	IN2505
TPA1380R01	TMA1380R01	TKA1380R01	13.8	0.5433	0.299	13.5	IN2505
TPA1390R01	TMA1390R01	TKA1390R01	13.9	0.5472	0.299	13.5	IN2505
TPA1400R01	TMA1400R01	TKA1400R01	14.0	0.5512	0.321	14	IN2505
TPA1410R01	TMA1410R01	TKA1410R01	14.1	0.5551	0.321	14	IN2505
TPA1420R01	TMA1420R01	TKA1420R01	14.2	0.5591	0.321	14	IN2505
TPA1430R01	TMA1430R01	TKA1430R01	14.3	0.5630	0.321	14	IN2505
TPA1440R01	TMA1440R01	TKA1440R01	14.4	0.5669	0.321	14	IN2505
TPA1450R01	TMA1450R01	TKA1450R01	14.5	0.5709	0.321	14.5	IN2505
TPA1460R01	TMA1460R01	TKA1460R01	14.6	0.5748	0.321	14.5	IN2505
TPA1470R01	TMA1470R01	TKA1470R01	14.7	0.5787	0.321	14.5	IN2505
TPA1480R01	TMA1480R01	TKA1480R01	14.8	0.5827	0.321	14.5	IN2505
TPA1490R01	TMA1490R01	TKA1490R01	14.9	0.5866	0.321	14.5	IN2505
TPA1500R01	TMA1500R01	TKA1500R01	15.0	0.5906	0.344	15	IN2505
TPA1510R01	TMA1510R01	TKA1510R01	15.1	0.5945	0.344	15	IN2505
TPA1520R01	TMA1520R01	TKA1520R01	15.2	0.5984	0.344	15	IN2505
TPA1530R01	TMA1530R01	TKA1530R01	15.3	0.6024	0.344	15	IN2505
TPA1540R01	TMA1540R01	TKA1540R01	15.4	0.6063	0.344	15	IN2505
TPA1550R01	TMA1550R01	TKA1550R01	15.5	0.6102	0.344	15	IN2505
TPA1560R01	TMA1560R01	TKA1560R01	15.6	0.6142	0.344	15	IN2505
TPA1570R01	TMA1570R01	TKA1570R01	15.7	0.6181	0.344	15	IN2505
TPA1580R01	TMA1580R01	TKA1580R01	15.8	0.6220	0.344	15	IN2505
TPA1590R01	TMA1590R01	TKA1590R01	15.9	0.6260	0.344	15	IN2505
TPA1600R01	TMA1600R01	TKA1600R01	16.0	0.6299	0.366	16	IN2505
TPA1610R01	TMA1610R01	TKA1610R01	16.1	0.6339	0.366	16	IN2505
TPA1620R01	TMA1620R01	TKA1620R01	16.2	0.6378	0.366	16	IN2505
TPA1630R01	TMA1630R01	TKA1630R01	16.3	0.6417	0.366	16	IN2505
TPA1640R01	TMA1640R01	TKA1640R01	16.4	0.6457	0.366	16	IN2505
TPA1650R01	TMA1650R01	TKA1650R01	16.5	0.6496	0.366	16	IN2505
TPA1660R01	TMA1660R01	TKA1660R01	16.6	0.6535	0.366	16	IN2505
TPA1670R01	TMA1670R01	TKA1670R01	16.7	0.6575	0.366	16	IN2505
TPA1680R01	TMA1680R01	TKA1680R01	16.8	0.6614	0.366	16	IN2505
TPA1690R01	TMA1690R01	TKA1690R01	16.9	0.6654	0.366	16	IN2505
TPA1700R01	TMA1700R01	TKA1700R01	17.0	0.6693	0.390	17	IN2505
TPA1710R01	TMA1710R01	TKA1710R01	17.1	0.6732	0.390	17	IN2505
TPA1720R01	TMA1720R01	TKA1720R01	17.2	0.6772	0.390	17	IN2505
TPA1730R01	TMA1730R01	TKA1730R01	17.3	0.6811	0.390	17	IN2505
TPA1740R01	TMA1740R01	TKA1740R01	17.4	0.6850	0.390	17	IN2505
TPA1750R01	TMA1750R01	TKA1750R01	17.5	0.6890	0.390	17	IN2505

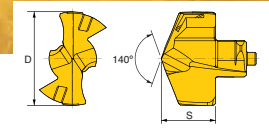

TIPS

"P" Geometry Steel	"M" Geometry Stainless Steel	"K" Geometry Cast Iron	(D) Diameter		S Dim (inch)	Pocket Size	Grade
			(mm)	(inch)			
TPA1760R01	TMA1760R01	TKA1760R01	17.6	0.6929	0.390	17	IN2505
TPA1770R01	TMA1770R01	TKA1770R01	17.7	0.6968	0.390	17	IN2505
TPA1780R01	TMA1780R01	TKA1780R01	17.8	0.7008	0.390	17	IN2505
TPA1790R01	TMA1790R01	TKA1790R01	17.9	0.7047	0.390	17	IN2505
TPA1800R01	TMA1800R01	TKA1800R01	18.0	0.7087	0.413	18	IN2505
TPA1810R01	TMA1810R01	TKA1810R01	18.1	0.7126	0.413	18	IN2505
TPA1820R01	TMA1820R01	TKA1820R01	18.2	0.7165	0.413	18	IN2505
TPA1830R01	TMA1830R01	TKA1830R01	18.3	0.7205	0.413	18	IN2505
TPA1840R01	TMA1840R01	TKA1840R01	18.4	0.7244	0.413	18	IN2505
TPA1850R01	TMA1850R01	TKA1850R01	18.5	0.7283	0.413	18	IN2505
TPA1860R01	TMA1860R01	TKA1860R01	18.6	0.7323	0.413	18	IN2505
TPA1870R01	TMA1870R01	TKA1870R01	18.7	0.7362	0.413	18	IN2505
TPA1880R01	TMA1880R01	TKA1880R01	18.8	0.7402	0.413	18	IN2505
TPA1890R01	TMA1890R01	TKA1890R01	18.9	0.7441	0.413	18	IN2505
TPA1900R01	TMA1900R01	TKA1900R01	19.0	0.7480	0.433	19	IN2505
TPA1905R01	TMA1905R01	TKA1905R01	19.05	0.7500	0.433	19	IN2505
TPA1910R01	TMA1910R01	TKA1910R01	19.1	0.7520	0.433	19	IN2505
TPA1920R01	TMA1920R01	TKA1920R01	19.2	0.7559	0.433	19	IN2505
TPA1930R01	TMA1930R01	TKA1930R01	19.3	0.7598	0.433	19	IN2505
TPA1940R01	TMA1940R01	TKA1940R01	19.4	0.7638	0.433	19	IN2505
TPA1950R01	TMA1950R01	TKA1950R01	19.5	0.7677	0.433	19	IN2505
TPA1960R01	TMA1960R01	TKA1960R01	19.6	0.7717	0.433	19	IN2505
TPA1970R01	TMA1970R01	TKA1970R01	19.7	0.7756	0.433	19	IN2505
TPA1980R01	TMA1980R01	TKA1980R01	19.8	0.7795	0.433	19	IN2505
TPA1990R01	TMA1990R01	TKA1990R01	19.9	0.7835	0.433	19	IN2505
TPA2000R01	TMA2000R01	TKA2000R01	20.0	0.7874	0.344	20	IN2505
TPA2010R01	TMA2010R01	TKA2010R01	20.1	0.7913	0.344	20	IN2505
TPA2020R01	TMA2020R01	TKA2020R01	20.2	0.7953	0.344	20	IN2505
TPA2030R01	TMA2030R01	TKA2030R01	20.3	0.7992	0.344	20	IN2505
TPA2040R01	TMA2040R01	TKA2040R01	20.4	0.8031	0.344	20	IN2505
TPA2050R01	TMA2050R01	TKA2050R01	20.5	0.8071	0.344	20	IN2505
TPA2060R01	TMA2060R01	TKA2060R01	20.6	0.8110	0.344	20	IN2505
TPA2070R01	TMA2070R01	TKA2070R01	20.7	0.8150	0.344	20	IN2505
TPA2080R01	TMA2080R01	TKA2080R01	20.8	0.8189	0.344	20	IN2505
TPA2090R01	TMA2090R01	TKA2090R01	20.9	0.8228	0.344	20	IN2505
TPA2100R01	TMA2100R01	TKA2100R01	21.0	0.8268	0.366	21	IN2505
TPA2110R01	TMA2110R01	TKA2110R01	21.1	0.8307	0.366	21	IN2505
TPA2120R01	TMA2120R01	TKA2120R01	21.2	0.8346	0.366	21	IN2505
TPA2130R01	TMA2130R01	TKA2130R01	21.3	0.8386	0.366	21	IN2505
TPA2140R01	TMA2140R01	TKA2140R01	21.4	0.8425	0.366	21	IN2505
TPA2150R01	TMA2150R01	TKA2150R01	21.5	0.8465	0.366	21	IN2505
TPA2160R01	TMA2160R01	TKA2160R01	21.6	0.8504	0.366	21	IN2505
TPA2170R01	TMA2170R01	TKA2170R01	21.7	0.8543	0.366	21	IN2505
TPA2180R01	TMA2180R01	TKA2180R01	21.8	0.8583	0.366	21	IN2505
TPA2190R01	TMA2190R01	TKA2190R01	21.9	0.8622	0.366	21	IN2505
TPA2200R01	TMA2200R01	TKA2200R01	22.0	0.8661	0.390	22	IN2505
TPA2210R01	TMA2210R01	TKA2210R01	22.1	0.8701	0.390	22	IN2505
TPA2220R01	TMA2220R01	TKA2220R01	22.2	0.8740	0.390	22	IN2505
TPA2222R01	TMA2222R01	TKA2222R01	22.22	0.8750	0.390	22	IN2505
TPA2230R01	TMA2230R01	TKA2230R01	22.3	0.8780	0.390	22	IN2505
TPA2240R01	TMA2240R01	TKA2240R01	22.4	0.8819	0.390	22	IN2505

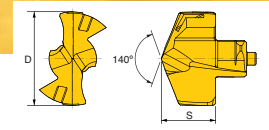

TIPS

"P" Geometry Steel	"M" Geometry Stainless Steel	"K" Geometry Cast Iron	(D) Diameter		S Dim (inch)	Pocket Size	Grade
			(mm)	(inch)			
TPA2250R01	TMA2250R01	TKA2250R01	22.5	0.8858	0.390	22	IN2505
TPA2260R01	TMA2260R01	TKA2260R01	22.6	0.8898	0.390	22	IN2505
TPA2270R01	TMA2270R01	TKA2270R01	22.7	0.8937	0.390	22	IN2505
TPA2280R01	TMA2280R01	TKA2280R01	22.8	0.8976	0.390	22	IN2505
TPA2290R01	TMA2290R01	TKA2290R01	22.9	0.9016	0.390	22	IN2505
TPA2300R01	TMA2300R01	TKA2300R01	23.0	0.9055	0.413	23	IN2505
TPA2310R01	TMA2310R01	TKA2310R01	23.1	0.9094	0.413	23	IN2505
TPA2320R01	TMA2320R01	TKA2320R01	23.2	0.9134	0.413	23	IN2505
TPA2330R01	TMA2330R01	TKA2330R01	23.3	0.9173	0.413	23	IN2505
TPA2340R01	TMA2340R01	TKA2340R01	23.4	0.9213	0.413	23	IN2505
TPA2350R01	TMA2350R01	TKA2350R01	23.5	0.9252	0.413	23	IN2505
TPA2360R01	TMA2360R01	TKA2360R01	23.6	0.9291	0.413	23	IN2505
TPA2370R01	TMA2370R01	TKA2370R01	23.7	0.9331	0.413	23	IN2505
TPA2380R01	TMA2380R01	TKA2380R01	23.8	0.9370	0.413	23	IN2505
TPA2390R01	TMA2390R01	TKA2390R01	23.9	0.9409	0.413	23	IN2505
TPA2400R01	TMA2400R01	TKA2400R01	24.0	0.9449	0.433	24	IN2505
TPA2410R01	TMA2410R01	TKA2410R01	24.1	0.9488	0.433	24	IN2505
TPA2420R01	TMA2420R01	TKA2420R01	24.2	0.9528	0.433	24	IN2505
TPA2430R01	TMA2430R01	TKA2430R01	24.3	0.9567	0.433	24	IN2505
TPA2440R01	TMA2440R01	TKA2440R01	24.4	0.9606	0.433	24	IN2505
TPA2450R01	TMA2450R01	TKA2450R01	24.5	0.9646	0.433	24	IN2505
TPA2460R01	TMA2460R01	TKA2460R01	24.6	3.9685	0.433	24	IN2505
TPA2470R01	TMA2470R01	TKA2470R01	24.7	0.9724	0.433	24	IN2505
TPA2480R01	TMA2480R01	TKA2480R01	24.8	0.9764	0.433	24	IN2505
TPA2490R01	TMA2490R01	TKA2490R01	24.9	0.9803	0.433	24	IN2505
TPA2500R01	TMA2500R01	TKA2500R01	25.0	0.9843	0.433	25	IN2505
TPA2510R01	TMA2510R01	TKA2510R01	25.1	0.9882	0.433	25	IN2505
TPA2520R01	TMA2520R01	TKA2520R01	25.2	0.9921	0.433	25	IN2505
TPA2530R01	TMA2530R01	TKA2530R01	25.3	0.9961	0.433	25	IN2505
TPA2540R01	TMA2540R01	TKA2540R01	25.4	1.0000	0.433	25	IN2505
TPA2550R01	TMA2550R01	TKA2550R01	25.5	1.0039	0.433	25	IN2505
TPA2560R01	TMA2560R01	TKA2560R01	25.6	1.0079	0.433	25	IN2505
TPA2570R01	TMA2570R01	TKA2570R01	25.7	1.0118	0.433	25	IN2505
TPA2580R01	TMA2580R01	TKA2580R01	25.8	1.0157	0.433	25	IN2505
TPA2590R01	TMA2590R01	TKA2590R01	25.9	1.0197	0.433	25	IN2505

* Aluminum geometry available as a special: TNA designation



SET UP (DRILLING TIP MOUNTING PROCEDURE)

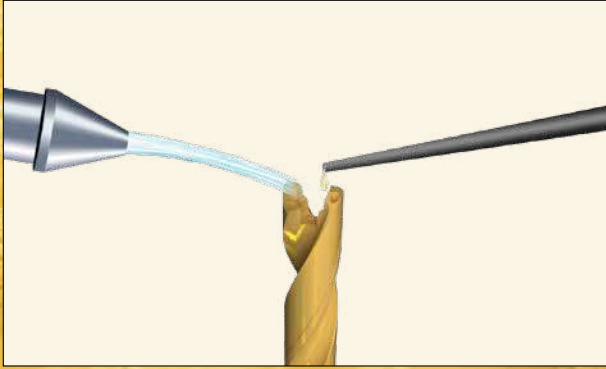

1. Clean the pocket and put oil

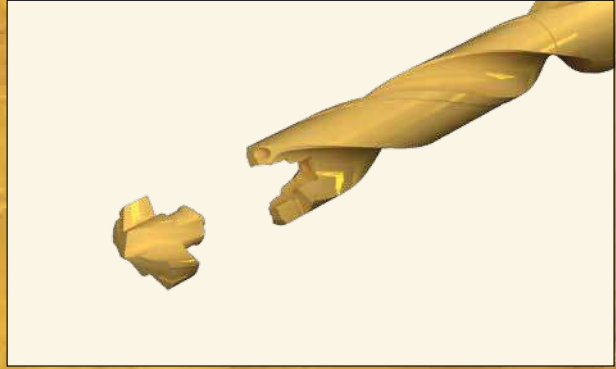

2. Mount the drill tip on the pocket

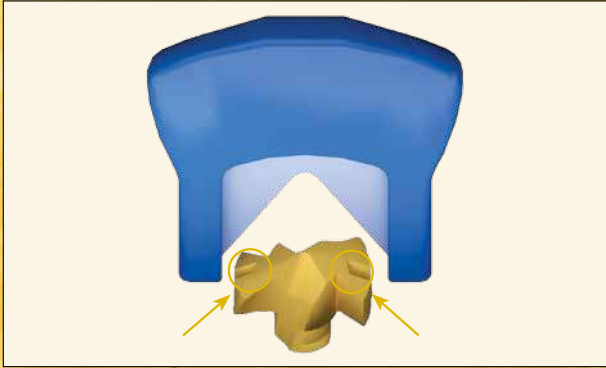

3. Insert key into the slots on tip

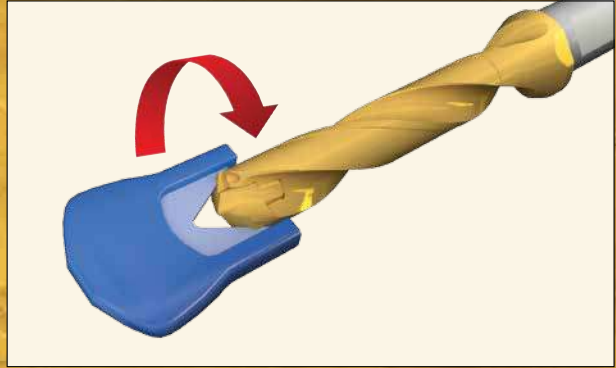

4. Tighten the tip by rotating the key CW

INDICATION OF HEAD WEAR

Wear Limit

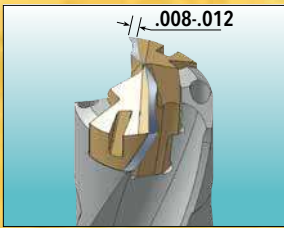

Power Restriction

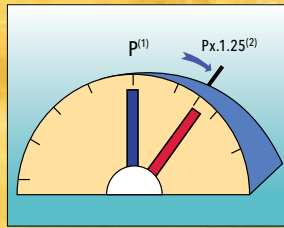

(1) New drilling head
(2) Worn-out drilling head

Vibration Noise Drastically Increases

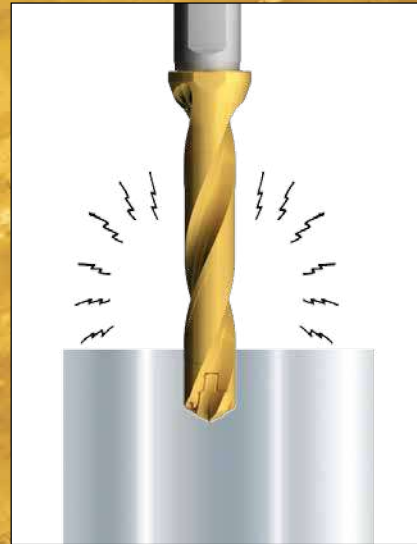

Diameter Change

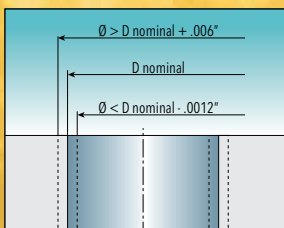

Surface Finish Declines

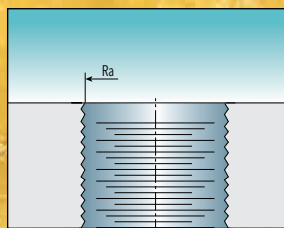

MAXIMUM RUNOUT

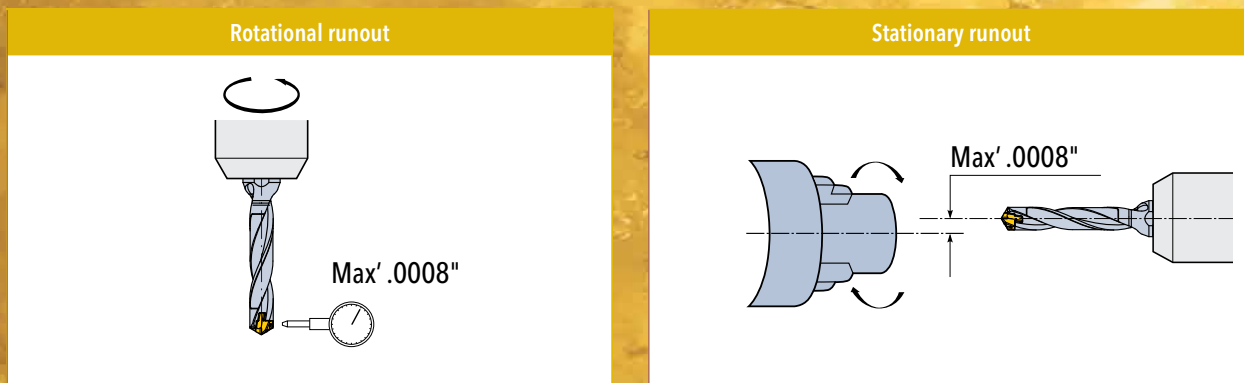

DRILLING LIMITATION



COOLANT RECOMMENDATIONS



RECOMMENDED PILOTING PROCEDURE FOR 8XD OR 12XD

1. Prior to using 8xD or 12xD drills, it is recommended to drill pilot holes from 0.5xD~1.5xD using a short drill (**GOLD•TWIST** 1.5xD holder is recommended).
2. Approach the pre-hole at reduced speed and feed until 2~5mm from it's bottom depth.
3. Increase up to recommended speed and maintain feed rate for 2~3 seconds applying coolant.
4. Start drilling at the recommended feed rate.

ISO	Material	Condition	Tensile Strength Rm (N/mm ²)	Hardness (HB)	Matl No.	Cutting Speed Vc (SFM)	Feed vs Drill Diameter					
							D= 7-9.9mm (.275-.390")	D= 10-11.9mm (.394-.469")	D= 12-13.9mm (.472-.547")	D= 14-15.9mm (.551-.626")	D= 16-19.9mm (.630-.783")	D= 20-25.9mm (.787-1.019")
							IPR (inches/rev)					
P	Non-alloy steel <0.25% C & cast steel, >= 0.25% C free cutting <0.55% C steel >= 0.55% C	Annealed	420	125	1	260-360-460	.005 .007 .009	.006 .008 .011	.007 .009 .012	.008 .011 .014	.010 .014 .018	.010 .014 .018
		Annealed	650	190	2	260-345-430						
		Quenched & Tempered	850	250	3	260-330-400						
		Annealed	750	220	4	230-295-360						
		Quenched & Tempered	1000	300	5	165-230-300						
	Low alloy steel & cast steel (less than 5% alloying elements)	Annealed	600	200	6	230-315-400	.005 .007 .010	.006 .008 .011	.006 .009 .013	.007 .010 .014	.009 .012 .016	.010 .014 .018
		Quenched & Tempered	930	275	7	230-295-360						
			1000	300	8	165-230-300						
	High alloy steel, cast steel, & tool steel	Annealed	680	200	10	165-230-300	.005 .006 .008	.005 .006 .007	.006 .008 .010	.007 .009 .011	.008 .010 .012	.009 .011 .013
		Quenched & Tempered	1100	325	11	130-200-265						
M	Stainless steel & cast stainless steel	Ferritic/martensitic	680	200	12	130-180-230	.004 .005 .006	.005 .006 .007	.006 .007 .008	.006 .008 .009	.006 .008 .010	.007 .009 .012
		Martensitic	820	240	13	130-180-230						
		Austenitic	600	180	14	100-165-230						
K	GreyCast Iron (GG)	Ferritic		160	15	300-410-525	.006 .009 .012	.008 .011 .014	.010 .013 .016	.012 .015 .018	.014 .018 .022	.014 .018 .024
		Pearlitic		250	16	265-360-460						
	Cast Iron Nodular (GGG)	Ferritic		180	17	300-450-600						
		Pearlitic		260	18	265-360-460						
	Malleable Cast Iron	Ferritic		130	19	300-410-525						
Pearlitic		230	20	265-360-460								
N	Aluminum - wrought alloy	Not cureable		60	21	300-510-725	.008 .011 .014	.010 .013 .016	.012 .015 .018	.014 .017 .020	.016 .020 .024	.018 .022 .028
		Cured		100	22	300-510-725						
	Aluminum - cast, alloyed	Not cureable		75	23	300-510-725						
		Cured		90	24	300-510-725						
	Copper alloys	High temperature		130	25	265-400-525						
		Free cutting		110	26	300-510-725						
		Brass		90	27	300-510-725						
	Non-metallic	Electrolitic copper		100	28	300-510-725						
Duro & fiber plastics				29	-							
Hard rubber				30	-							
S	High temp alloys Fe based Ni or Co based	Annealed		200	31	100-150-200	.002 .003 .004	.003 .004 .005	.004 .005 .006	.005 .006 .007	.005 .006 .008	.006 .007 .009
		Cured		280	32	70-115-165						
		Annealed		250	33	70-115-165						
		Cured		350	34	70-115-165						
		Cast		320	35	70-115-165						
	Titanium, Ti alloys		Rm 400		36	70-115-165						
		Alpha+beta alloys cured	Rm 1050		37	70-115-165						
H	Hardened steel	Hardened		55 HRC	38	70-115-165	.002 .004 .005	.003 .004 .006	.004 .006 .007	.005 .007 .008	.006 .007 .009	.006 .008 .010
		Hardened		60 HRC	39	70-115-165						
	Chilled cast iron	Cast		400	40	-						
	Cast iron nodular	Hardened		55 HRC	41	-						

* Feed Rates are based on Two Effective - DO NOT DOUBLE.

GOLD TWIST

DRILL LINE

AN ECONOMICAL DRILL/CHAMFER COMBO SOLUTION FOR INCH AND METRIC TAP SIZES

Drill Body Features

- Cost effective solution that replaces the high cost of special solid carbide step drills
- A twisted through coolant channel for smooth chip evacuation & high penetration rates
- Two symmetrically designed standard chamfering inserts firmly seated for optimal performance via balanced cutting
- Eliminates the need for solid carbide drill regrinding

Insert Features

- Widely capable KOMT insert is designed for both chamfering and countersinking
- Indexable inserts include two cutting edges for optimum chip control
- Capable of machining a wide range of workpiece materials
- Indexable inserts mean economy and flexibility over a wide range of applications



METRIC BODIES

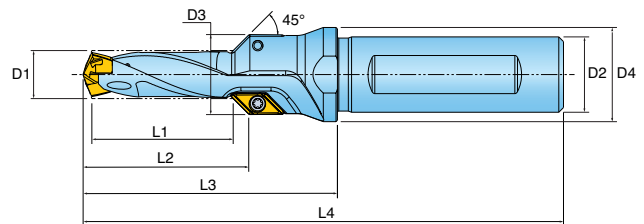

BODY	Thread	D1	D3	L1	Dimensions (inch)					Pocket Size
					L2	L3	D2	D4	L4	
TC0850026JCR01	M10	.335 (8.5mm)	.610	1.024	1.20	1.96	.472 (12.0mm)	.630	3.73	8.5
TC1020030JDR01	M12	.402 (10.2mm)	.669	1.181	1.36	2.13	.630 (16.0mm)	.787	4.02	10
TC1200035JDR01	M14	.472 (12.0mm)	.748	1.378	1.56	2.40	.630 (16.0mm)	.787	4.29	12
TC1400039JER01	M16	.551 (14.0mm)	.827	1.535	1.71	2.72	.787 (20.0mm)	.984	4.69	14
TC1750042JER01	M20	.689 (17.5mm)	.965	1.653	1.83	2.83	.787 (20.0mm)	1.062	4.80	17
TC2100048JFR01	M24	.827 (21.0mm)	1.102	1.890	2.07	3.15	.984 (25.0mm)	1.259	5.35	21

INCH BODIES

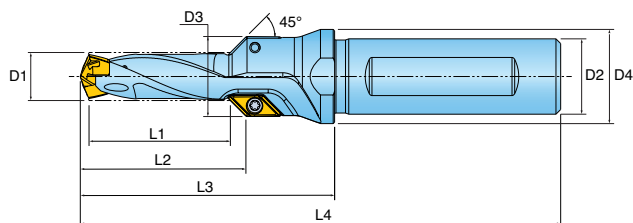

BODY	Thread	Dimensions (inch)								Pocket Size
		D1	D3	L1	L2	L3	D2	D4	L4	
TC0790025B9R01	3/8 UNC	.311 (7.9mm)	.590	1.000	1.18	1.97	.500 (12.7mm)	.630	3.74	7.5
TC0850025B9R01	3/8 UNF	.335 (8.5mm)	.610	1.000	1.18	2.01	.500 (12.7mm)	.630	3.78	8.5
TC0940026B9R01	7/16 UNC	.370 (9.4mm)	.650	1.059	1.24	2.13	.500 (12.7mm)	.709	3.90	9, 9.5
TC0990026B9R01	7/16 UNF	.390 (9.9mm)	.669	1.059	1.24	2.13	.500 (12.7mm)	.709	3.90	9
TC1080026COR01	1/2 UNC	.425 (10.8mm)	.709	1.059	1.24	2.17	.625 (15.88mm)	.787	4.06	10.5
TC1150026COR01	1/2 UNF	.453 (11.5mm)	.728	1.059	1.24	2.20	.625 (15.88mm)	.787	4.09	11.5
TC1230026COR01	9/16 UNC	.484 (12.3mm)	.768	1.059	1.24	2.24	.625 (15.88mm)	.866	4.13	12
TC1300026COR01	9/16 UNF	.512 (13.0mm)	.787	1.059	1.24	2.28	.625 (15.88mm)	.866	4.17	13
TC137003018R01	5/8 UNC	.539 (13.7mm)	.807	1.201	1.38	2.40	.750 (19.05mm)	.984	4.37	13.5
TC146003018R01	5/8 UNF	.575 (14.6mm)	.827	1.201	1.38	2.44	.750 (19.05mm)	.984	4.41	14.5
TC167003518R01	3/4 UNC	.658 (16.7mm)	.925	1.402	1.58	2.76	.750 (19.05mm)	.984	4.73	16
TC175003518R01	3/4 UNF	.689 (17.5mm)	.965	1.402	1.58	2.83	.750 (19.05mm)	.984	4.80	17
TC1950041C8R01	7/8 UNC	.768 (19.5mm)	1.043	1.650	1.83	3.15	1.000 (25.4mm)	1.260	5.35	19
TC2050041C8R01	7/8 UNF	.807 (20.5mm)	1.083	1.650	1.83	3.23	1.000 (25.4mm)	1.260	5.43	20

INSERT



IN2005, IN2505

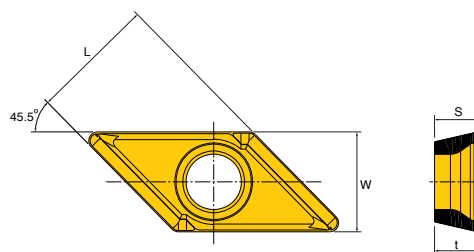

DESIGNATION	Dimensions (inch)					Screw	Wrench
	W	L	S	t			
KOMT050104R	.177	.223	.085	.077		TS220461	TD7P



QUADOTWIST™ DRILL

NEW GENERATION OF INDEXABLE DRILL

- 4 cornered economical insert design.
- Grade IN2505 can be used for both inboard and outboard pockets.
- Improved machinability due to ideally configured cutting edge.
- Applicable to most materials including low carbon and mild steel.
- Twisted coolant design provides for excellent chip evacuation and better hole quality.
- Enhanced insert durability with new grade (IN2505).
- New extended length shank (R02).
 - Allows two set screw contact for lathe applications.
 - Cut-off notch added for ease of shortening in rotating applications, if necessary.



IN2505 (PVD) - GENERAL PURPOSE

- Sub-micron grade with high hardness and toughness
- New Multi-layered coating for higher chipping resistance
- Post-coat surface treatment improves chipping resistance and reduces cutting forces
- First choice for general applications



IN6505 (CVD) - STEEL APPLICATION

- Multi-layered CVD coating along with post coat surface treatment provides excellent wear resistance and improves chipping resistance
- Peripheral (Outboard) pocket only



IN1030 (PVD) - CAST IRON, STAINLESS, TITANIUM

- Tough, slower speed applications
- More forgiving when machine rigidity is an issue.

R02

R01



276

FINE GOLD 2013/2014

QR SERIES INDEXABLE DRILL

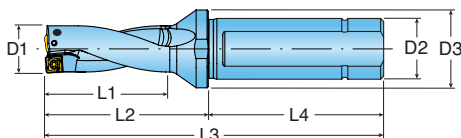

Drill Number	2xD Bodies		Dimensions (inch)						Insert	Screw	Torx	Plug
	D1 (mm)	D1 (inch)	D2 Shank Dia	D3 Fig Dia	L1 Max. DOC	L2 Ext From Holder	L3 OAL	L4 Shank Lgth				
* QR0143029N5R02	14.3	0.563			1.13	2.13	5.28	3.16				
* QR0150030N5R02	15.0	0.591			1.19	2.24	5.39	3.16	SOMT050204SK	SM20-043-00	TD 6P	PF-0012
* QR0159032N5R02	15.9	0.626			1.25	2.36	5.51	3.16				
* QR0167033N5R02	16.7	0.658			1.31	2.44	5.59	3.16				
* QR0175035N5R02	17.5	0.689			1.38	2.56	5.71	3.16				
* QR0183037N5R02	18.3	0.721	1.00	1.26	1.44	2.56	5.71	3.16	SOMT060204SK	TS 22052I/HG-P	TD 7P	PF-0012
* QR0191038N5R02	19.1	0.750			1.50	2.64	5.79	3.16				
* QR0198040N5R02	19.8	0.781			1.56	2.80	5.94	3.16				
* QR0206041N5R02	20.6	0.813			1.63	2.87	6.02	3.16				
* QR0214042N5R02	21.4	0.843			1.69	2.95	6.10	3.16	SOMT070306SK	TS 22052I/HG-P	TD 7P	PF-0012
* QR0222044N5R02	22.2	0.875			1.75	2.95	6.10	3.16				
* QR0230046N6R02	23.0	0.906			1.81	3.19	6.34	3.16				
* QR0238048N6R02	23.8	0.938			1.88	3.31	6.46	3.16				
* QR0246049N6R02	24.6	0.969	1.25	1.77	1.94	3.43	6.57	3.16	SOMT08T306SK	SO 25065I	DS-T07S	PF-0013
* QR0250050N5R02	25.0	0.984			1.97	3.43	6.58	3.16				
* QR0254051N6R02	25.4	1.000			2.00	3.50	6.65	3.16				
* QR0262052N6R02	26.2	1.031			2.06	3.50	6.65	3.16				
QR0270054N6R02	27.0	1.063			2.13	3.58	6.73	3.16				
QR0278056N6R02	27.8	1.094			2.19	3.70	6.85	3.16				
QR0286058N6R02	28.6	1.125	1.25	1.77	2.25	3.78	6.93	3.16	SOMT09T306SK	SM35-088-60	TD 10	PF-0013
QR0294058N6R02	29.4	1.156			2.31	3.98	7.13	3.16				
QR0302060N6R02	30.2	1.187			2.37	3.98	7.13	3.16				
QR0310062N6R02	31.0	1.219			2.44	4.09	7.24	3.16				
QR0318063N6R02	31.8	1.250			2.50	4.17	7.32	3.16				
QR0325065N6R02	32.5	1.281			2.56	4.29	7.44	3.16				
QR0333067N6R02	33.3	1.312	1.25	1.77	2.62	4.29	7.44	3.16	SOMT11T308SK	SM35-088-60	TD 10	PF-0013
QR0341068N6R02	34.1	1.343			2.69	4.37	7.52	3.16				
QR0349070N6R02	34.9	1.375			2.75	4.49	7.64	3.16				
QR0357071N6R02	35.7	1.406			2.81	4.61	7.76	3.16				
QR0365073N6R02	36.5	1.437			2.87	4.72	7.87	3.16				
QR0373075N6R02	37.3	1.468			2.94	4.72	7.87	3.16				
QR0381076N6R02	38.1	1.500			3.00	4.84	7.99	3.16				
QR0389078N6R02	38.9	1.531	1.25	2.16	3.06	4.92	8.07	3.16	SOMT130408SK	SE02-82	TD 15	PF-0013
QR0397079N6R02	39.7	1.562			3.12	5.04	8.19	3.16				
QR0405081N6R02	40.5	1.594			3.12	5.16	8.31	3.16				
QR0413083N6R02	41.3	1.625			3.25	5.16	8.31	3.16				
QR0428086N7R02	42.8	1.687			3.37	5.35	8.50	3.16				
QR0437087N7R02	43.7	1.719			3.44	5.43	8.58	3.16				
QR0445089N7R02	44.5	1.750			3.50	5.59	8.74	3.16				
QR0452090N7R02	45.2	1.781			3.56	5.59	8.74	3.16				
QR0460092N7R02	46.0	1.813	1.50	2.36	3.63	5.71	8.86	3.16	SOMT150510SK	SM50-113-20	TD 20	PF-0013
QR0476095N7R02	47.6	1.875			3.75	5.91	9.06	3.16				
QR0492098N7R02	49.2	1.937			3.87	5.98	9.13	3.16				
QR0500100N7R02	50.0	1.969			3.94	6.10	9.25	3.16				
QR0508102N7R02	50.8	2.000			4.00	6.22	9.37	3.16				

* Standard shank (R01) will be phased out and replaced by R02. Brass Coolant Plugs, PF-0012 & PF-0013, are sold separately.

QR SERIES INDEXABLE DRILL

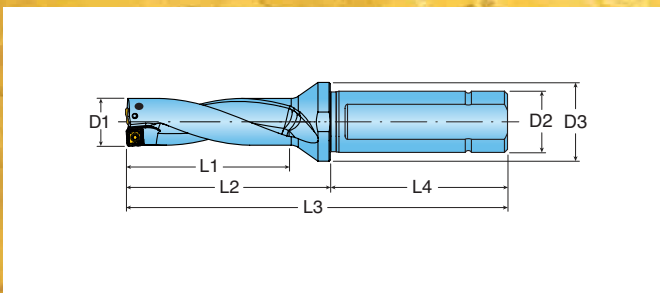

3xD Bodies			Dimensions (inch)							Insert	Screw	Torx	Plug	
Drill Number	D1 (mm)	D1 (inch)	D2 Shank Dia	D3 Fig Dia	L1 Max. DOC	L2 Ext From Holder	L3 OAL	L4 Shank Lgth						
*QR0143043N5R02	14.3	0.563	1.00	1.26	1.69	2.68	5.83	3.16	SOMT050204SK	SM20-043-00	TD 6P	PF-0012		
*QR0150045N5R02	15.0	0.591			1.78	2.83	5.98	3.16						
*QR0159048N5R02	15.9	0.626			1.87	2.99	6.14	3.16						
*QR0167050N5R02	16.7	0.658			1.25	1.77	1.97	3.11	6.26	3.16	SOMT060204SK	TS 22052I/HG-P	TD 7P	PF-0012
*QR0175053N5R02	17.5	0.689					2.06	3.27	6.42	3.16				
*QR0183055N5R02	18.3	0.721					2.16	3.27	6.42	3.16				
*QR0191057N5R02	19.1	0.750					2.25	3.39	6.54	3.16				
*QR0198059N5R02	19.8	0.781					2.34	3.58	6.73	3.16				
*QR0206062N5R02	20.6	0.813			1.25	1.77	2.44	3.70	6.85	3.16	SOMT070306SK	TS 22052I/HG-P	TP 7P	PF-0012
*QR0214064N5R02	21.4	0.843					2.53	3.82	6.97	3.16				
*QR0222067N5R02	22.2	0.875	2.63	3.82			6.97	3.16						
*QR0230069N6R02	23.0	0.906	2.72	4.09			7.24	3.16						
*QR0238071N6R02	23.8	0.938	2.81	4.25			7.40	3.16						
*QR0246074N6R02	24.6	0.969	2.91	4.41			7.56	3.16						
*QR0250075N5R02	25.0	0.984	2.95	4.41			7.56	3.16						
*QR0254076N6R02	25.4	1.000	3.00	4.53			7.68	3.16						
*QR0262079N6R02	26.2	1.031	3.09	4.53			7.68	3.16						
QR0270081N6R02	27.0	1.063	3.19	4.65			7.80	3.16						
QR0278083N6R02	27.8	1.094	1.25	1.77	3.28	4.80	7.95	3.16	SOMT08T306SK	SO 25065I	DS-T07S	PF-0013		
QR0286086N6R02	28.6	1.125			3.38	4.92	8.07	3.16						
QR0294088N6R02	29.4	1.156			3.47	5.16	8.30	3.16						
QR0302090N6R02	30.2	1.187			3.56	5.16	8.30	3.16						
QR0310093N6R02	31.0	1.219			3.66	5.31	8.46	3.16						
QR0318095N6R02	31.8	1.250			3.75	5.43	8.58	3.16						
QR0325098N6R02	32.5	1.281	1.25	1.77	3.84	5.59	8.74	3.16	SOMT09T306SK	SM35-088-60	TD 10	PF-0013		
QR0333100N6R02	33.3	1.312			3.94	5.59	8.74	3.16						
QR0341102N6R02	34.1	1.343			4.03	5.71	8.86	3.16						
QR0349105N6R02	34.9	1.375			4.13	5.87	9.02	3.16						
QR0357107N6R02	35.7	1.406			4.22	6.02	9.17	3.16						
QR0365110N6R02	36.5	1.437			4.31	6.18	9.33	3.16						
QR0373112N6R02	37.3	1.468	1.25	2.16	4.41	6.18	9.33	3.16	SOMT11T308SK	SM35-088-60	TD 10	PF-0013		
QR0381114N6R02	38.1	1.500			4.50	6.34	9.49	3.16						
QR0389117N6R02	38.9	1.531			4.59	6.46	9.61	3.16						
QR0397119N6R02	39.7	1.562			4.69	6.61	9.76	3.16						
QR0405122N6R02	40.5	1.594			4.69	6.77	9.92	3.16						
QR0413124N6R02	41.3	1.625			4.87	6.77	9.92	3.16						
QR0428128N7R02	42.8	1.687	1.50	2.36	5.06	7.05	10.20	3.16	SOMT130408SK	SE02-82	TD 15	PF-0013		
QR0437131N7R02	43.7	1.719			1.50	2.36	5.16	7.17						
QR0445134N7R02	44.5	1.750			5.25	7.36	10.51	3.16						
QR0452136N7R02	45.2	1.781			5.34	7.36	10.51	3.16						
QR0460138N7R02	46.0	1.813			5.44	7.52	10.67	3.16						
QR0476143N7R02	47.6	1.875			5.63	7.80	10.94	3.16						
QR0492148N7R02	49.2	1.937			5.81	7.91	11.06	3.16						
QR0500150N7R02	50.0	1.969			5.91	8.07	11.22	3.16						
QR0508152N7R02	50.8	2.000			6.00	8.23	11.38	3.16						

* Standard shank (R01) will be phased out and replaced by R02.
Brass Coolant Plugs, PF-0012 & PF-0013, are sold separately.

QR SERIES INDEXABLE DRILL

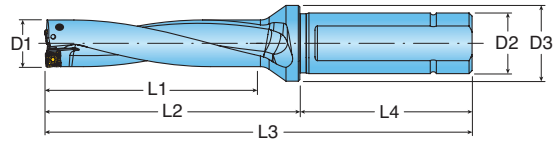

4xD Bodies		Dimensions (inch)								Insert	Screw	Torx	Plug
Drill Number	D1 (mm)	D1 (inch)	D2 Shank Dia	D3 Fig Dia	L1 Max. DOC	L2 Ext From Holder	L3 OAL	L4 Shank Lgth					
*QR0143057N5R02	14.3	0.563	1.00	1.26	2.25	3.23	6.38	3.16	SOMT050204SK	SM20-043-00	TD 6P	PF-0012	
*QR0150060N5R02	15.0	0.591			2.37	3.43	6.57	3.16					
*QR0159064N5R02	15.9	0.626			2.50	3.62	6.77	3.16					
*QR0167067N5R02	16.7	0.658			2.63	3.78	6.93	3.16					
*QR0175070N5R02	17.5	0.689			2.75	3.98	7.13	3.16					
*QR0183073N5R02	18.3	0.721			2.87	3.98	7.13	3.16					
*QR0191076N5R02	19.1	0.750			3.00	4.13	7.28	3.16					
*QR0198079N5R02	19.8	0.781			3.13	4.37	7.52	3.16					
*QR0206082N5R02	20.6	0.813			3.25	4.53	7.68	3.16					
*QR0214086N5R02	21.4	0.843			3.37	4.69	7.83	3.16					
*QR0222089N5R02	22.2	0.875	3.50	4.69	7.83	3.16	SOMT070306SK	TS 22052I/HG-P	TP 7P	PF-0012			
*QR0230092N6R02	23.0	0.906	3.62	5.00	8.15	3.16							
*QR0238095N6R02	23.8	0.938	3.75	5.20	8.35	3.16							
*QR0246098N6R02	24.6	0.969	3.87	5.39	8.54	3.16							
*QR0250100N5R02	25.0	0.984	3.94	5.39	8.54	3.16							
*QR0254102N6R02	25.4	1.000	4.00	5.55	8.70	3.16							
*QR0262105N6R02	26.2	1.031	4.13	5.55	8.70	3.16							
QR0270108N6R02	27.0	1.063	4.25	5.71	8.86	3.16							
QR0278111N6R02	27.8	1.094	4.38	5.91	9.06	3.16							
QR0286114N6R02	28.6	1.125	4.50	6.06	9.21	3.16							
QR0294118N6R02	29.4	1.156	4.62	6.34	9.49	3.16	SOMT09T306SK	SM35-088-60	TD 10	PF-0013			
QR0302120N6R02	30.2	1.187	4.75	6.34	9.49	3.16							
QR0310124N6R02	31.0	1.219	4.87	6.54	9.69	3.16							
QR0318127N6R02	31.8	1.250	5.00	6.69	9.84	3.16							
QR0325130N6R02	32.5	1.281	5.13	6.89	10.04	3.16							
QR0333133N6R02	33.3	1.312	5.25	6.89	10.04	3.16							
QR0341136N6R02	34.1	1.343	5.37	7.05	10.20	3.16							
QR0349140N6R02	34.9	1.375	5.50	7.24	10.39	3.16							
QR0357143N6R02	35.7	1.406	5.62	7.44	10.59	3.16							
QR0365146N6R02	36.5	1.437	5.75	7.64	10.79	3.16							
QR0373149N6R02	37.3	1.468	5.87	7.64	10.79	3.16	SOMT130408SK	SE02-82	TD 15	PF-0013			
QR0381152N6R02	38.1	1.500	6.00	7.83	10.98	3.16							
QR0389156N6R02	38.9	1.531	6.13	7.99	11.14	3.16							
QR0397159N6R02	39.7	1.562	6.25	8.19	11.34	3.16							
QR0405162N6R02	40.5	1.594	6.25	8.39	11.54	3.16							
QR0413165N6R02	41.3	1.625	6.50	8.39	11.54	3.16							
QR0428171N7R02	42.8	1.687	6.75	8.74	11.89	3.16							
QR0437175N7R02	43.7	1.719	1.50	2.36	6.87	8.90							
QR0445178N7R02	44.5	1.750	7.00	9.13	12.28	3.16							
QR0452181N7R02	45.2	1.781	7.13	9.13	12.28	3.16							
QR0460184N7R02	46.0	1.813	7.25	9.33	12.48	3.16	SOMT150510SK	SM50-113-20	TD 20	PF-0013			
QR0476190N7R02	47.6	1.875	7.50	9.69	12.83	3.16							
QR0492197N7R02	49.2	1.937	7.75	9.84	12.99	3.16							
QR0500200N7R02	50.0	1.969	7.87	10.04	13.19	3.16							
QR0508203N7R02	50.8	2.000	8.00	10.24	13.39	3.16							

* Standard shank (R01) will be phased out and replaced by R02.
Brass Coolant Plugs, PF-0012 & PF-0013, are sold separately.

QR SERIES INDEXABLE DRILL

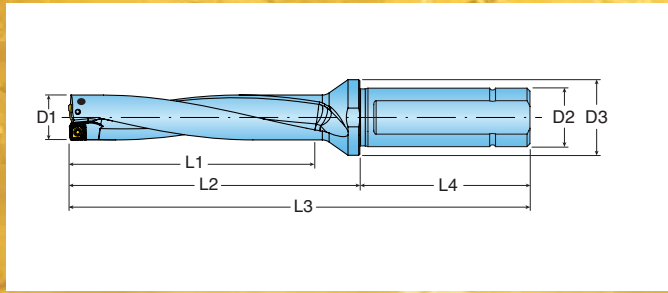

Drill Number	5xD Bodies		Dimensions (inch)						Insert	Screw	Torx	Plug
	D1 (mm)	D1 (inch)	D2 Shank Dia	D3 Fig Dia	L1 Max. DOC	L2 Ext From Holder	L3 OAL	L4 Shank Lgth				
*QR0143072N5R02	14.3	0.563			2.81	3.78	6.94	3.16				
*QR0150075N5R02	15.0	0.591			2.96	4.02	7.17	3.16	SOMT050204SK	SM20-043-00	TD 6P	PF-0012
*QR0159080N5R02	15.9	0.626			3.13	4.25	7.40	3.16				
*QR0167083N5R02	16.7	0.658			3.29	4.45	7.60	3.16				
*QR0175087N5R02	17.5	0.689			3.44	4.69	7.84	3.16				
*QR0183091N5R02	18.3	0.721	1.00	1.26	3.59	4.69	7.84	3.16	SOMT060204SK	TS 22052I/HG-P	TD 7P	PF-0012
*QR0191095N5R02	19.1	0.750			3.75	4.88	8.03	3.16				
*QR0198099N5R02	19.8	0.781			3.91	5.16	8.31	3.16				
*QR0206103N5R02	20.6	0.813			4.07	5.35	8.50	3.16				
*QR0214107N5R02	21.4	0.843			4.22	5.55	8.70	3.16	SOMT070306SK	TS 22052I/HG-P	TP 7P	PF-0012
*QR0222111N5R02	22.2	0.875			4.38	5.55	8.70	3.16				
*QR0230115N6R02	23.0	0.906			4.53	5.91	9.06	3.16				
*QR0238119N6R02	23.8	0.938			4.69	6.14	9.29	3.16				
*QR0246123N6R02	24.6	0.969	1.25	1.77	4.85	6.38	9.53	3.16	SOMT08T306SK	SO 25065I	DS-T07S	PF-0013
*QR0250125N5R02	25.0	0.984			4.85	6.38	9.53	3.16				
*QR0254127N6R02	25.4	1.000			5.00	6.57	9.72	3.16				
*QR0262131N6R02	26.2	1.031			5.16	6.57	9.72	3.16				
QR0270135N6R02	27.0	1.063			5.31	6.77	9.92	3.16				
QR0278139N6R02	27.8	1.094			5.47	7.01	10.15	3.16				
QR0286143N6R02	28.6	1.125	1.25	1.77	5.63	7.20	10.34	3.16	SOMT09T306SK	SM35-088-60	TD 10	PF-0013
QR0294147N6R02	29.4	1.156			5.78	7.52	10.64	3.16				
QR0302151N6R02	30.2	1.187			5.94	7.52	10.68	3.16				
QR0310155N6R02	31.0	1.219			6.09	7.76	10.90	3.16				
QR0318159N6R02	31.8	1.250			6.25	7.95	11.09	3.16				
QR0325163N6R02	32.5	1.281			6.41	8.19	11.32	3.16				
QR0333167N6R02	33.3	1.312	1.25	1.77	6.56	8.19	11.35	3.16	SOMT11T308SK	SM35-088-60	TD 10	PF-0013
QR0341171N6R02	34.1	1.343			6.72	8.39	11.54	3.16				
QR0349175N6R02	34.9	1.375			6.88	8.62	11.77	3.16				
QR0357179N6R02	35.7	1.406			7.03	8.86	12.00	3.16				
QR0365182N6R02	36.5	1.437			7.19	9.09	12.24	3.16				
QR0373186N6R02	37.3	1.468			7.34	9.09	12.24	3.16				
QR0381191N6R02	38.1	1.500			7.50	9.33	12.26	3.16				
QR0389194N6R02	38.9	1.531	1.25	2.16	7.66	9.53	12.67	3.16	SOMT130408SK	SE02-82	TD 15	PF-0013
QR0397198N6R02	39.7	1.562			7.81	9.76	12.91	3.16				
QR0405202N6R02	40.5	1.594			7.81	10.00	13.15	3.16				
QR0413206N6R02	41.3	1.625			8.13	10.00	13.15	3.16				

* Standard shank (R01) will be phased out and replaced by R02.
Brass Coolant Plugs, PF-0012 & PF-0013, are sold separately.

SOMT SK

GRADE: IN2505
For General Purpose

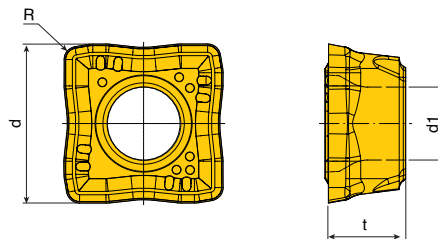

GRADE: IN6505
For Steel Applications
For Peripheral Pockets Only

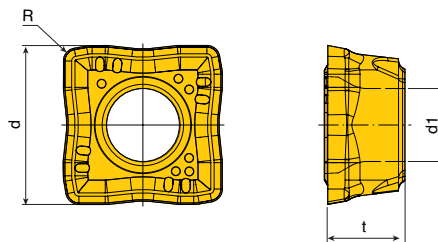

GRADE: IN1030
For Cast Iron, Stainless
and Titanium Applications

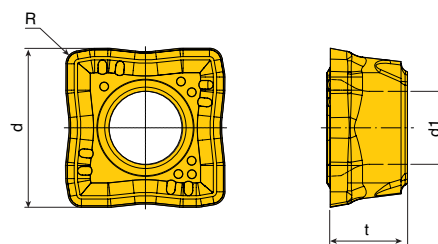

Designation	Dimension (inch)				Tool Diameter Range
	d	t	R	d1	
SOMT 050204 SK	0.193	0.094	0.016	0.089	14.00mm(.5512") - 16.49mm(.6492")
SOMT 060204 SK	0.224	0.094	0.016	0.102	16.50mm(.6496") - 19.49mm(.7673")
SOMT 070306 SK	0.268	0.110	0.024	0.102	19.50mm(.7677") - 22.49mm(.8854")
SOMT 08T306 SK	0.311	0.156	0.024	0.112	22.50mm(.8858") - 26.49mm(1.0429")
SOMT 09T308 SK	0.362	0.156	0.031	0.149	26.50mm(1.0433") - 31.49mm(1.2397")
SOMT 11T308 SK	0.433	0.156	0.031	0.149	31.50mm(1.2401") - 36.99mm(1.4563")
SOMT 130408 SK	0.504	0.173	0.031	0.173	37.00mm(1.4567") - 43.49mm(1.7122")
SOMT 150510 SK	0.590	0.189	0.039	0.212	43.50mm(1.7126") - 50.00mm(1.9685")

All QuadTwist inserts available in Grades IN1030, IN2505 and IN6505.

RADIAL ADJUSTMENT

Drill Diameter	Insert	Max. Radial (X)	Max. Dia
0.563" (14.3mm)		0.015	0.593
0.594" (15.0mm)	SOMT 050204 SK	0.013	0.620
0.626" (15.9mm)		0.011	0.648
0.657" (16.7mm)		0.018	0.693
0.688" (17.5mm)	SOMT 060204 SK	0.013	0.714
0.719" (18.3mm)		0.011	0.741
0.750" (19.1mm)		0.010	0.770
0.781" (19.8mm)		0.020	0.821
0.813" (20.6mm)		0.015	0.843
0.843" (21.4mm)	SOMT 070306 SK	0.011	0.865
0.875" (22.2mm)		0.008	0.891
0.906" (23.0mm)		0.025	0.956
0.938" (23.8mm)		0.022	0.982
0.969" (24.6mm)	SOMT 08T306 SK	0.018	1.005
0.984" (25.0mm)		0.015	1.014
1.000" (25.4mm)		0.015	1.030
1.031" (26.2mm)		0.011	1.053
1.063" (27.0mm)		0.028	1.119
1.094" (27.8mm)		0.024	1.142
1.125" (28.6mm)		0.015	1.155
1.156" (29.4mm)	SOMT 09T308 SK	0.015	1.186
1.187" (30.2mm)		0.011	1.209
1.219" (31.0mm)		0.008	1.235
1.250" (31.8mm)		0.035	1.320
1.281" (32.5mm)		0.031	1.343
1.312" (33.3mm)		0.031	1.374
1.343" (34.1mm)	SOMT 11T308 DP	0.028	1.399
1.375" (34.9mm)		0.024	1.423
1.406" (35.7mm)		0.015	1.436

Drill Diameter	Insert	Max. Radial (X)	Max. Dia
1.437" (36.5mm)		0.047	1.531
1.468" (37.3mm)		0.047	1.562
1.500" (38.1mm)		0.039	1.578
1.531" (38.9mm)	SOMT 130408 DP	0.035	1.601
1.562" (39.7mm)		0.028	1.618
1.594" (40.5mm)		0.024	1.642
1.625" (41.3mm)		0.024	1.673
1.687" (42.8mm)		0.012	1.711
1.719" (43.7mm)		0.047	1.813
1.750" (44.5mm)		0.043	1.836
1.781" (45.2mm)		0.043	1.867
1.813" (46.0mm)	SOMT 150510 DP	0.039	1.891
1.875" (47.6mm)		0.028	1.931
1.937" (49.2mm)		0.024	1.985
1.969" (50.0mm)		0.020	2.009
2.000" (50.8mm)		0.015	2.030

4 CORNERED INSERT DESIGN

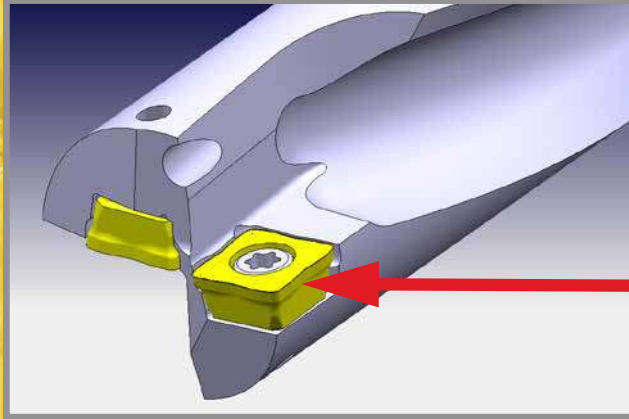

2XD, 3XD AND 4XD RECOMMENDED CUTTING CONDITIONS

ISO	Material	Condition	Tensile Strength Rm (N/mm ²)	Hardness (HB)	Matl No.	Cutting Speed Vc (SFM)	Feed v.s. Drill Diameter In/Rev Drill Length 2, 3, 4xD							
							SOMT 05 0.551-.645 (inch)	SOMT 06 0.649-.763 (inch)	SOMT 07 0.767-.882 (inch)	SOMT 08 0.886-1.039 (inch)	SOMT 09 1.063-1.220 (inch)	SOMT 11 1.250-1.460 (inch)	SOMT 13 1.437-1.687 (inch)	SOMT 15 1.719-2.000 (inch)
P	Non-alloy steel <0.25% C & cast steel, >= 0.25% C free cutting C steel >= 0.55% C	Annealed	420	125	1	700-1200	.002-.003	.002-.003	.002-.004	.002-.004	.003-.004	.003-.005	.003-.005	.003-.005
		Annealed	650	190	2	600-950	.003-.004	.003-.004	.003-.005	.003-.005	.003-.006	.003-.006	.003-.0065	.003-.0065
		Quenched & Tempered	850	250	3	450-800	.003-.005	.003-.005	.003-.006	.003-.006	.004-.006	.004-.006	.004-.007	.004-.007
		Annealed	750	220	4	450-800	.003-.005	.003-.005	.003-.006	.003-.006	.004-.007	.004-.007	.004-.007	.004-.007
		Quenched & Tempered	1000	300	5	450-800	.003-.005	.003-.005	.003-.006	.003-.006	.004-.007	.004-.007	.004-.007	.004-.007
	Low alloy steel & cast steel (less than 5% alloying elements)	Annealed	600	200	6	450-800	.003-.006	.003-.006	.003-.007	.003-.007	.004-.007	.004-.009	.004-.009	.004-.0095
		Quenched & Tempered	930	275	7	325-600	.003-.006	.003-.006	.003-.008	.003-.008	.004-.008	.004-.0085	.004-.0085	.004-.0085
			1000	300	8	325-600	.003-.006	.003-.006	.003-.008	.003-.008	.004-.008	.004-.0085	.004-.0085	.004-.0085
			1200	350	9	325-600	.003-.006	.003-.006	.003-.008	.003-.008	.004-.008	.004-.0085	.004-.0085	.004-.0085
	High alloy steel, cast steel, & tool steel	Annealed	680	200	10	450-675	.002-.005	.0025-.005	.0025-.005	.003-.006	.004-.007	.004-.007	.004-.008	.004-.008
		Quenched & Tempered	1100	325	11	325-525	.0025-.005	.0025-.005	.003-.006	.003-.006	.0035-.007	.0035-.008	.004-.008	.004-.008
M	Stainless steel & cast stainless steel	Ferritic/martensitic	680	200	12	500-800	.0025-.005	.0025-.005	.003-.006	.003-.006	.003-.007	.0035-.008	.004-.008	.004-.008
		Martensitic	820	240	13	500-800	.0025-.005	.0025-.005	.003-.006	.003-.006	.003-.007	.0035-.008	.004-.008	.004-.008
		Austenitic	600	180	14	500-800	.0025-.005	.0025-.005	.003-.006	.003-.006	.003-.007	.0035-.008	.004-.008	.004-.008
K	GreyCast Iron (GG)	Ferritic		160	15	525-850	.003-.007	.003-.007	.004-.008	.004-.008	.004-.008	.004-.008	.004-.0085	.004-.0085
		Pearlitic		250	16	525-850	.003-.007	.003-.007	.004-.008	.004-.008	.004-.008	.004-.008	.004-.0085	.004-.0085
	Cast Iron Nodular (GGG)	Ferritic		180	17	525-850	.003-.007	.003-.007	.004-.008	.004-.008	.004-.008	.004-.008	.004-.0085	.004-.0085
		Pearlitic		260	18	525-850	.003-.007	.003-.007	.004-.008	.004-.008	.004-.008	.004-.008	.004-.0085	.004-.0085
	Malleable Cast Iron	Ferritic		130	19	400-725	.003-.0055	.003-.0055	.004-.006	.004-.006	.004-.0065	.004-.007	.004-.007	.004-.007
Pearlitic			230	20	400-725	.003-.0055	.003-.0055	.004-.006	.004-.006	.004-.0065	.004-.007	.004-.007	.004-.007	
N	Aluminum - wrought alloy	Not cureable		60	21	650-1150	.0025-.006	.0025-.006	.003-.0065	.003-.0065	.0035-.007	.0035-.007	.004-.0075	.004-.0075
		Cured		100	22	650-1150	.0025-.006	.0025-.006	.003-.0065	.003-.0065	.0035-.007	.0035-.007	.004-.0075	.004-.0075
	Aluminum - cast, alloyed	Not cureable		75	23	650-1150	.0025-.006	.0025-.006	.003-.0065	.003-.0065	.0035-.007	.0035-.007	.004-.0075	.004-.0075
		Cured		90	24	650-1150	.0025-.006	.0025-.006	.003-.0065	.003-.0065	.0035-.007	.0035-.007	.004-.0075	.004-.0075
		High temperature		130	25	650-1150	.0025-.006	.0025-.006	.003-.0065	.003-.0065	.0035-.007	.0035-.007	.004-.0075	.004-.0075
	1% Pb Copper alloys	Free cutting		110	26	490-825	.0025-.006	.0025-.006	.003-.0065	.003-.0065	.004-.007	.004-.007	.004-.008	.004-.008
		Brass		90	27	490-825	.0025-.006	.0025-.006	.003-.0065	.003-.0065	.004-.007	.004-.007	.004-.008	.004-.008
		Electrolytic copper		100	28	490-825	.0025-.006	.0025-.006	.003-.0065	.003-.0065	.004-.007	.004-.007	.004-.008	.004-.008
	Non-metallic	Duro & fiber plastics			29	490-825	.0025-.006	.0025-.006	.003-.0065	.003-.0065	.004-.007	.004-.007	.004-.008	.004-.008
		Hard rubber			30	490-825	.0025-.006	.0025-.006	.003-.0065	.003-.0065	.004-.007	.004-.007	.004-.008	.004-.008
S	Fe based High temp alloys	Annealed		200	31	100-200	.002-.003	.002-.003	.002-.0035	.002-.0035	.003-.004	.003-.004	.003-.005	.003-.005
		Cured		280	32	100-200	.002-.003	.002-.003	.002-.0035	.002-.0035	.003-.004	.003-.004	.003-.005	.003-.005
		Annealed		250	33	100-200	.002-.003	.002-.003	.002-.0035	.002-.0035	.003-.004	.003-.004	.003-.005	.003-.005
		Cured		350	34	100-200	.002-.003	.002-.003	.002-.0035	.002-.0035	.003-.004	.003-.004	.003-.005	.003-.005
		Cast		320	35	100-200	.002-.003	.002-.003	.002-.0035	.002-.0035	.003-.004	.003-.004	.003-.005	.003-.005
	Titanium, Ti alloys		Rm 400		36	165-265	.0025-.0035	.0025-.0035	.003-.004	.003-.004	.003-.004	.003-.004	.003-.004	.003-.004
		Alpha+beta alloys cured	Rm 1050		37	165-265	.0025-.0035	.0025-.0035	.003-.004	.003-.004	.003-.004	.003-.004	.003-.004	.003-.004
H	Hardened steel	Hardened		55 HRC	38	100-200	.002-.0035	.002-.0035	.002-.004	.002-.004	.002-.0045	.002-.0045	.002-.0045	.002-.0045
		Hardened		60 HRC	39	100-200	.002-.0035	.002-.0035	.002-.004	.002-.004	.002-.0045	.002-.0045	.002-.0045	.002-.0045
	Chilled cast iron	Cast		400	40	100-200	.002-.0035	.002-.0035	.002-.004	.002-.004	.002-.0045	.002-.0045	.002-.0045	.002-.0045
	Cast iron nodular	Hardened		55 HRC	41	100-200	.002-.0035	.002-.0035	.002-.004	.002-.004	.002-.0045	.002-.0045	.002-.0045	.002-.0045

5XD RECOMMENDED CUTTING CONDITIONS

ISO	Material	Condition	Tensile Strength Rm (N/mm²)	Hardness (HB)	Matl No.	Cutting Speed Vc (SFM)	Feed v.s. Drill Diameter In/Rev Drill Length 5xD							
							SOMT 05 0.551-.645 (inch)	SOMT 06 0.649-.763 (inch)	SOMT 07 0.767-.882 (inch)	SOMT 08 0.886-1.039 (inch)	SOMT 09 1.063-1.220 (inch)	SOMT 11 1.250-1.460 (inch)	SOMT 13 1.437-1.687 (inch)	SOMT 15 1.719-2.000 (inch)
P	Non-alloy steel <0.25% C & cast steel, >= 0.25% C free cutting C steel >= 0.55% C	Annealed	420	125	1	700-1200	.0015-.002	.0015-.002	.0015-.002	.0015-.002	.0025-.0035	.0025-.0035	.0025-.004	.0025-.004
		Annealed	650	190	2	600-950	.002-.003	.002-.003	.002-.004	.002-.004	.003-.005	.003-.005	.003-.0055	.003-.0055
		Quenched & Tempered	850	250	3	450-800	.002-.004	.002-.004	.003-.005	.003-.005	.003-.007	.003-.006	.004-.007	.004-.007
		Annealed	750	220	4	450-800	.002-.004	.002-.004	.003-.005	.003-.005	.003-.007	.003-.006	.004-.007	.004-.007
		Quenched & Tempered	1000	300	5	450-800	.002-.004	.002-.004	.003-.005	.003-.005	.003-.007	.003-.006	.004-.007	.004-.007
	Low alloy steel & cast steel (less than 5% alloying elements)	Annealed	600	200	6	450-800	.002-.005	.002-.005	.003-.006	.003-.006	.003-.007	.003-.008	.003-.008	.004-.0085
		Quenched & Tempered	930	275	7	325-600	.002-.005	.002-.005	.003-.006	.003-.006	.003-.007	.003-.008	.003-.008	.004-.0085
			1000	300	8	325-600	.002-.005	.002-.005	.003-.006	.003-.006	.003-.007	.003-.008	.003-.008	.004-.0085
	High alloy steel, cast steel, & tool steel	1200	350	9	325-600	.002-.005	.002-.005	.003-.006	.003-.006	.003-.007	.003-.008	.003-.008	.004-.0085	
		Annealed	680	200	10	450-675	.002-.004	.002-.004	.003-.005	.003-.005	.003-.006	.003-.007	.003-.007	.004-.008
	Quenched & Tempered	1100	325	11	325-525	.002-.004	.002-.004	.003-.005	.003-.005	.003-.006	.003-.007	.004-.007	.004-.008	
	Stainless steel & cast stainless steel	Ferritic/martensitic	680	200	12	500-800	.002-.004	.002-.004	.003-.005	.003-.005	.003-.006	.003-.007	.004-.007	.004-.008
Martensitic		820	240	13	500-800	.002-.004	.002-.004	.003-.005	.003-.005	.003-.006	.003-.007	.004-.007	.004-.008	
Austenitic		600	180	14	500-800	.002-.004	.002-.004	.003-.005	.003-.005	.003-.006	.003-.007	.004-.007	.004-.008	
K	GreyCast Iron (GG)	Ferritic		160	15	525-850	.003-.0055	.003-.0055	.003-.006	.003-.006	.004-.007	.004-.007	.004-.008	.004-.008
		Pearlitic		250	16	525-850	.003-.0055	.003-.0055	.003-.006	.003-.006	.004-.007	.004-.007	.004-.008	.004-.008
	Cast Iron Nodular (GGG)	Ferritic		180	17	525-850	.003-.0055	.003-.0055	.003-.006	.003-.006	.004-.007	.004-.007	.004-.008	.004-.008
		Pearlitic		260	18	525-850	.003-.0055	.003-.0055	.003-.006	.003-.006	.004-.007	.004-.007	.004-.008	.004-.008
	Malleable Cast Iron	Ferritic		130	19	400-725	.0025-.0045	.0025-.0045	.003-.0055	.003-.0055	.004-.006	.004-.006	.004-.0065	.004-.0065
		Pearlitic		230	20	400-725	.0025-.0045	.0025-.0045	.003-.0055	.003-.0055	.004-.006	.004-.006	.004-.0065	.004-.0065
N	Aluminum - wrought alloy	Not cureable		60	21	650-1150	.002-.0055	.002-.0055	.0025-.006	.0025-.006	.003-.006	.003-.006	.0035-.007	.0035-.007
		Cured		100	22	650-1150	.002-.0055	.002-.0055	.0025-.006	.0025-.006	.003-.006	.003-.006	.0035-.007	.0035-.007
	Aluminum - cast, alloyed Si <=12% Si >12% Si	Not cureable		75	23	650-1150	.002-.0055	.002-.0055	.0025-.006	.0025-.006	.003-.006	.003-.006	.0035-.007	.0035-.007
		Cured		90	24	650-1150	.002-.0055	.002-.0055	.0025-.006	.0025-.006	.003-.006	.003-.006	.0035-.007	.0035-.007
	1% Pb Copper alloys	Free cutting		110	26	490-825	.002-.0055	.002-.0055	.003-.006	.003-.006	.003-.0065	.003-.0065	.0035-.0075	.0035-.0075
		Brass		90	27	490-825	.002-.0055	.002-.0055	.003-.006	.003-.006	.003-.0065	.003-.0065	.0035-.0075	.0035-.0075
		Electrolytic copper		100	28	490-825	.002-.0055	.002-.0055	.003-.006	.003-.006	.003-.0065	.003-.0065	.0035-.0075	.0035-.0075
	Non-metallic	Duro & fiber plastics			29	490-825	.002-.0055	.002-.0055	.0025-.006	.0025-.006	.003-.006	.0035-.006	.0035-.0075	.0035-.0075
		Hard rubber			30	490-825	.002-.0055	.002-.0055	.0025-.006	.0025-.006	.003-.006	.0035-.006	.0035-.0075	.0035-.0075
	S	based High temp alloys Fe _____ Ni or Co based	Annealed		200	31	100-200	.0015-.0025	.0015-.0025	.0015-.0025	.0015-.0025	.0025-.0035	.0025-.0035	.0025-.004
Cured				280	32	100-200	.0015-.0025	.0015-.0025	.0015-.0025	.0015-.0025	.0025-.0035	.0025-.0035	.0025-.004	.0025-.004
Annealed				250	33	100-200	.0015-.0025	.0015-.0025	.0015-.0025	.0015-.0025	.0025-.0035	.0025-.0035	.0025-.004	.0025-.004
Cured				350	34	100-200	.0015-.0025	.0015-.0025	.0015-.0025	.0015-.0025	.0025-.0035	.0025-.0035	.0025-.004	.0025-.004
Cast				320	35	100-200	.0015-.0025	.0015-.0025	.0015-.0025	.0015-.0025	.0025-.0035	.0025-.0035	.0025-.004	.0025-.004
Titanium, Ti alloys			Rm 400		36	165-265	.002-.003	.002-.003	.0025-.0035	.0025-.0035	.0025-.0035	.0025-.0035	.0025-.0035	.0025-.0035
		Alpha+beta alloys cured	Rm 1050		37	165-265	.002-.003	.002-.003	.0025-.0035	.0025-.0035	.0025-.0035	.0025-.0035	.0025-.0035	.0025-.0035
H	Hardened steel	Hardened		55 HRC	38	100-200	.0015-.003	.0015-.003	.0015-.0035	.0015-.0035	.0015-.004	.0015-.004	.0015-.004	.0015-.004
		Hardened		60 HRC	39	100-200	.0015-.003	.0015-.003	.0015-.0035	.0015-.0035	.0015-.004	.0015-.004	.0015-.004	.0015-.004
	Chilled cast iron	Cast		400	40	100-200	.0015-.003	.0015-.003	.0015-.0035	.0015-.0035	.0015-.004	.0015-.004	.0015-.004	
	Cast iron nodular	Hardened		55 HRC	41	100-200	.0015-.003	.0015-.003	.0015-.0035	.0015-.0035	.0015-.004	.0015-.004	.0015-.004	

CHAMFERING RINGS

FOR

GOLD•TWIST **QUAD•TWIST**
DRILL LINE DRILL
QUAD•DRILL+

- Available for 3xD, 5xD & 8xD GOLD•TWIST and 3xD & 4xD QUAD•TWIST & QUAD•DRILL+
- Adjustable step length
- Reduces cycle time by combining two operations into one



Ingersoll, the supplier of cost competitive, high productivity indexable drill lines, now introduces chamfering rings to promote machining convenience for end-users in hole making applications.

Ingersoll chamfering rings can be used to drill and chamfer in a single operation to minimize cycle time as well as reduce inventory of special combination tools.

All chamfering rings are compatible with GOLD•TWIST, QUAD•TWIST and QUAD•DRILL+ bodies to control drilling depth. The specially treated, multi-layered PVD coated CRNG inserts enable stable machining and long tool life.

CHAMFERING RINGS

45° CHAMFERING RING - 2 EFFECTIVE INSERTS

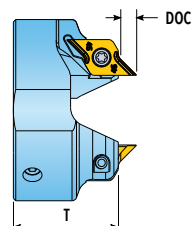
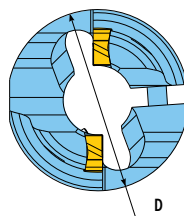

Description	D (inch)	T (inch)	Fits Gold Twist Series	Fits Quad Twist Series	Fits Quad Drill+ Series	Maximum Chamfer Size
			Dia. Range (mm)	Dia. Range (mm)	Dia. Range (mm)	
CB140R02	1.50	.866	13.5 - 14.4	13.5 - 14.4	13.5 - 14.4	.118 x 45°
CB150R02	1.50	.866	14.5 - 15.9	14.5 - 15.4	14.5 - 15.4	.118 x 45°
CB160R02	1.65	.906	16.0 - 16.9	15.5 - 16.4	15.5 - 16.4	.118 x 45°
CB170R02	1.65	.906	17.0 - 17.9	16.5 - 17.4	16.5 - 17.4	.118 x 45°
CB180R02	1.65	.906	18.0 - 18.9	17.5 - 18.4	17.5 - 18.4	.118 x 45°
CB190R02	1.65	.945	19.0 - 19.9	18.5 - 19.4	18.5 - 19.4	.118 x 45°
CB200R02	1.65	.945	20.0 - 20.9	19.5 - 20.4	19.5 - 20.4	.118 x 45°

NOTE: For use with GOLD•TWIST 3, 5 & 8xD and QUAD•TWIST & QUAD•DRILL+ 3 & 4xD.

INSERTS

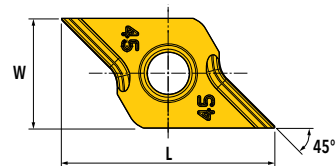
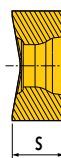

Designation	L	W	S	Grade
CRNG-0802-45CD	.583	.295	.144	IN2505

HARDWARE

Description	Insert Screw	Torx	Clamping Screw	Wrench
CB140R02	SO 250651	DS-T07S	SHM4x0.7x12 ⁽¹⁾	L-W3
CB150R02	SO 250651	DS-T07S	SHM4x0.7x12 ⁽¹⁾	L-W3
CB160R02	SO 250651	DS-T07S	SHM5x0.8x16 ⁽²⁾	L-W4
CB170R02	SO 250651	DS-T07S	SHM5x0.8x16 ⁽²⁾	L-W4
CB180R02	SO 250651	DS-T07S	SHM5x0.8x16 ⁽²⁾	L-W4
CB190R02	SO 250651	DS-T07S	SHM5x0.8x16 ⁽²⁾	L-W4
CB200R02	SO 250651	DS-T07S	SHM5x0.8x16 ⁽²⁾	L-W4

⁽¹⁾ Clamping torque: 4 [N•m] 36 [lbf-in]

⁽²⁾ Clamping torque: 7-8 [N•m] 84-96 [lbf-in]

CHAMFERING RINGS

FOR **GOLD TWIST**
DRILLING

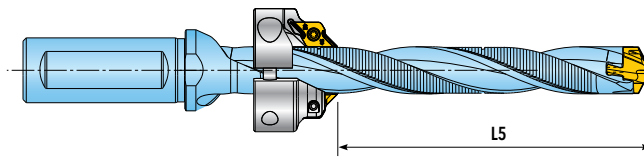

L:D	Body Designation		Ring Designation	L5 (min) inch	L5 (max) inch
	Cylindrical Shank	Shank with Flat			
3	TD1400042S6R01	TD1400042C0R01	CB140R02	0.630	0.866
	TD1450043S6R01	TD1450043C0R01	CB140R02	0.630	0.866
	TD1500045S7R01	TD150004518R01	CB150R02	0.670	0.984
	TD1600048S7R01	TD160004818R01	CB160R02	0.709	1.102
	TD1700051S7R01	TD170005118R01	CB170R02	0.748	1.22
	TD1800054S1R01	TD1800054C8R01	CB180R02	0.787	1.339
	TD1900057S1R01	TD1900057C8R01	CB190R02	0.827	1.457
	TD2000060S1R01	TD2000060C8R01	CB200R02	0.866	1.575
5	TD1400070S6R01	TD1400070C0R01	CB140R02	0.787	1.969
	TD1450072S6R01	TD1450072C0R01	CB140R02	0.787	1.969
	TD1500075S7R01	TD150007518R01	CB150R02	0.906	2.165
	TD1600080S7R01	TD160008018R01	CB160R02	1.024	2.362
	TD1700085S7R01	TD170008518R01	CB170R02	1.142	2.559
	TD1800090S1R01	TD1800090C8R01	CB180R02	1.260	2.756
	TD1900095S1R01	TD1900095C8R01	CB190R02	1.378	2.953
	TD2000100S1R01	TD2000100C8R01	CB200R02	1.496	3.15
8	TD1400112S6R01	TD1400112C0R01	CB140R02	1.890	3.622
	TD1450116S6R01	TD1450116C0R01	CB140R02	1.890	3.622
	TD1500120S7R01	TD150012018R01	CB150R02	2.087	3.937
	TD1600128S7R01	TD160012818R01	CB160R02	2.283	4.252
	TD1700136S7R01	TD170013618R01	CB170R02	2.480	4.567
	TD1800144S1R01	TD1800144C8R01	CB180R02	2.677	4.882
	TD1900152S1R01	TD1900152C8R01	CB190R02	2.874	5.197
	TD2000160S1R01	TD2000160C8R01	CB200R02	3.071	5.512

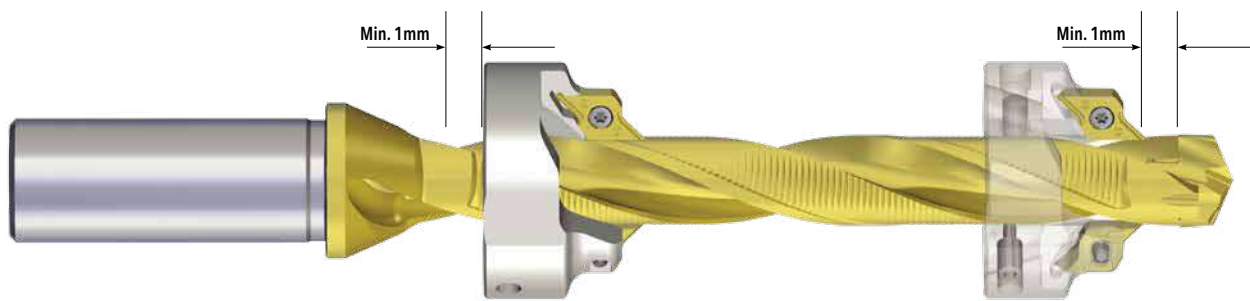

CHAMFERING RINGS

FOR **QUAD•TWIST™** **QUAD•DRILL+™**

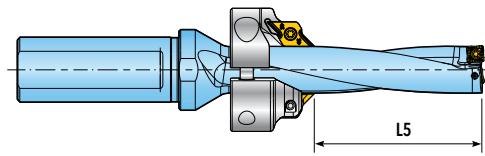

L:D	Body Designation		Ring Designation	L5 (min) inch	L5 (max) inch
	QUAD•TWIST	QUAD•DRILL+			
3	QR0143043N5R01/R02	Q0143043N5R01/R02	CB140R02	0.551	0.709
	QR0150045N5R01/R02	Q0150045N5R01/R02	CB150R02	0.591	0.827
	QR0159048N5R01/R02	Q0159048N5R01/R02	CB160R02	0.630	0.945
	QR0167050N5R01/R02	Q0167050N5R01/R02	CB170R02	0.670	1.062
	QR0175053N5R01/R02	Q0175053N5R01/R02	CB180R02	0.709	1.181
	QR0183055N5R01/R02	Q0183055N5R01/R02	CB180R02	0.709	1.181
	QR0191057N5R01/R02	Q0191057N5R01/R02	CB190R02	0.748	1.299
	QR0198059N5R01/R02	Q0198059N5R01/R02	CB200R02	0.787	1.417
4	QR0143057N5R01/R02	Q0143057N5R01/R02	CB140R02	0.630	1.260
	QR0150060N5R01/R02	Q0150060N5R01/R02	CB150R02	0.748	1.417
	QR0159064N5R01/R02	Q0159064N5R01/R02	CB160R02	0.866	1.575
	QR0167067N5R01/R02	Q0167067N5R01/R02	CB170R02	0.984	1.732
	QR0175070N5R01/R02	Q0175070N5R01/R02	CB180R02	1.102	1.890
	QR0183073N5R01/R02	Q0183073N5R01/R02	CB180R02	1.102	1.890
	QR0191076N5R01/R02	Q0191076N5R01/R02	CB190R02	1.220	2.047
	QR0198079N5R01/R02	Q0198079N5R01/R02	CB200R02	1.339	2.204

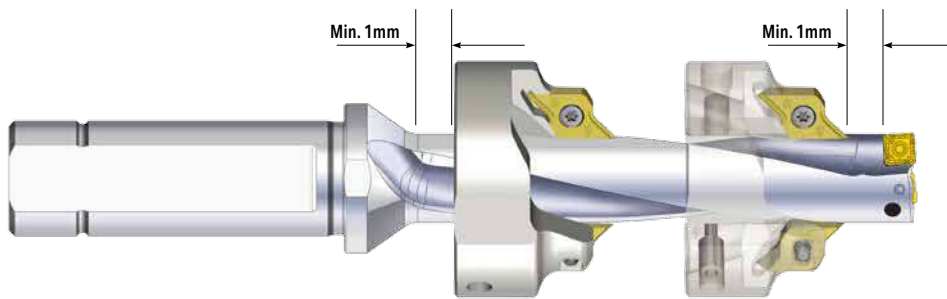

CHAMFERING RINGS

ASSEMBLY OF CHAMFERING RING



1. Insert the chamfering ring on to the drill body.
The stopper must be inside the flute.



2. Slide the chamfering ring to the desired position.

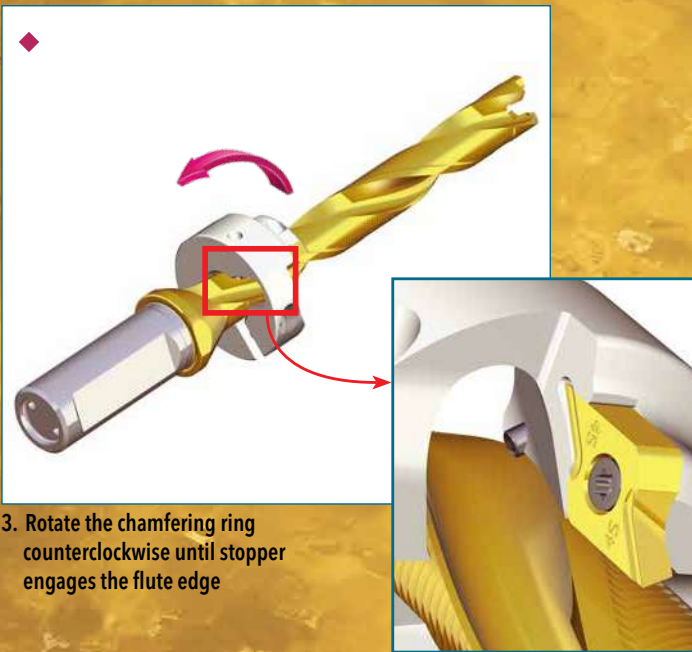

3. Rotate the chamfering ring
counterclockwise until stopper
engages the flute edge

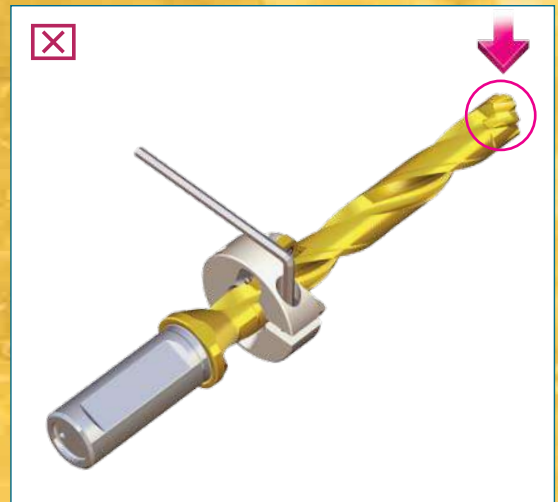

4. Tighten the chamfering ring and clamp the drill head.

**When the chamfering ring is clamped correctly,
the drill flute will be aligned with the chamfering ring flute.**

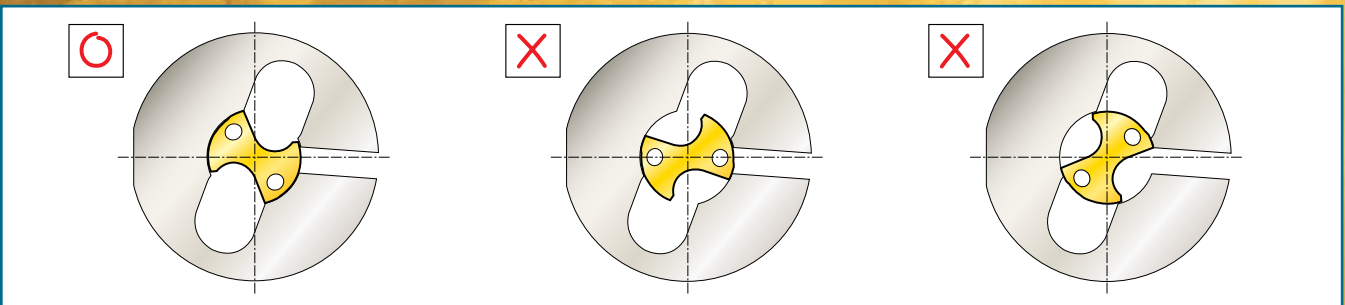

CHAMFERING RINGS

RECOMMENDATIONS FOR STABLE MACHINING

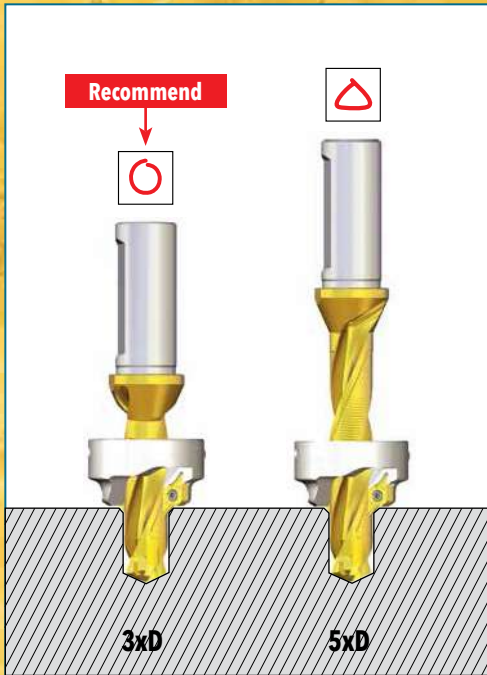

1. If possible, always use a short holder.
If not, reduce the cutting speed to minimize vibration.



2. Mount the chamfering ring as close as possible to the drilling shank.

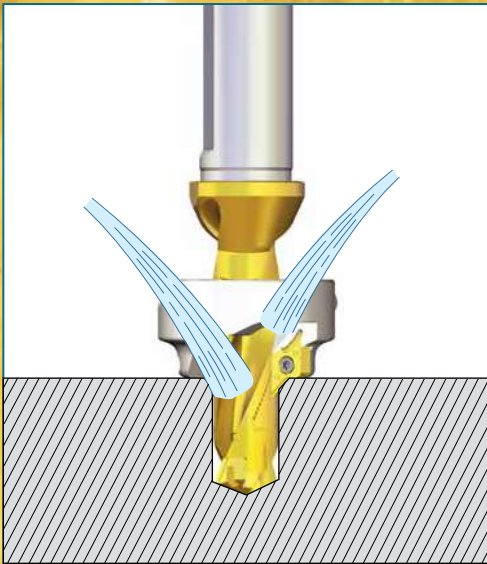

3. For better insert life, apply external coolant to the insert and internal coolant to the drill tip.

QUADODRILL⁺

QA ADJUSTABLE DRILLS

NEW GENERATION OF INDEXABLE DRILL

- Adjustability enables multiple diameters with the same body.
- Five drill bodies cover (17) standard sizes.
- Minimum Drill inventory for Cost savings.
- Two coolant access ports, side port specifically for non-rotational lathe drilling applications.
- Cartridge design protects the drill body - a significant feature on larger size expensive drill bodies.
- 4 inserts per body: 2 cartridges per body, 2 inserts per cartridges.

• QUADODRILL⁺ SERIES QA DRILL ASSEMBLY

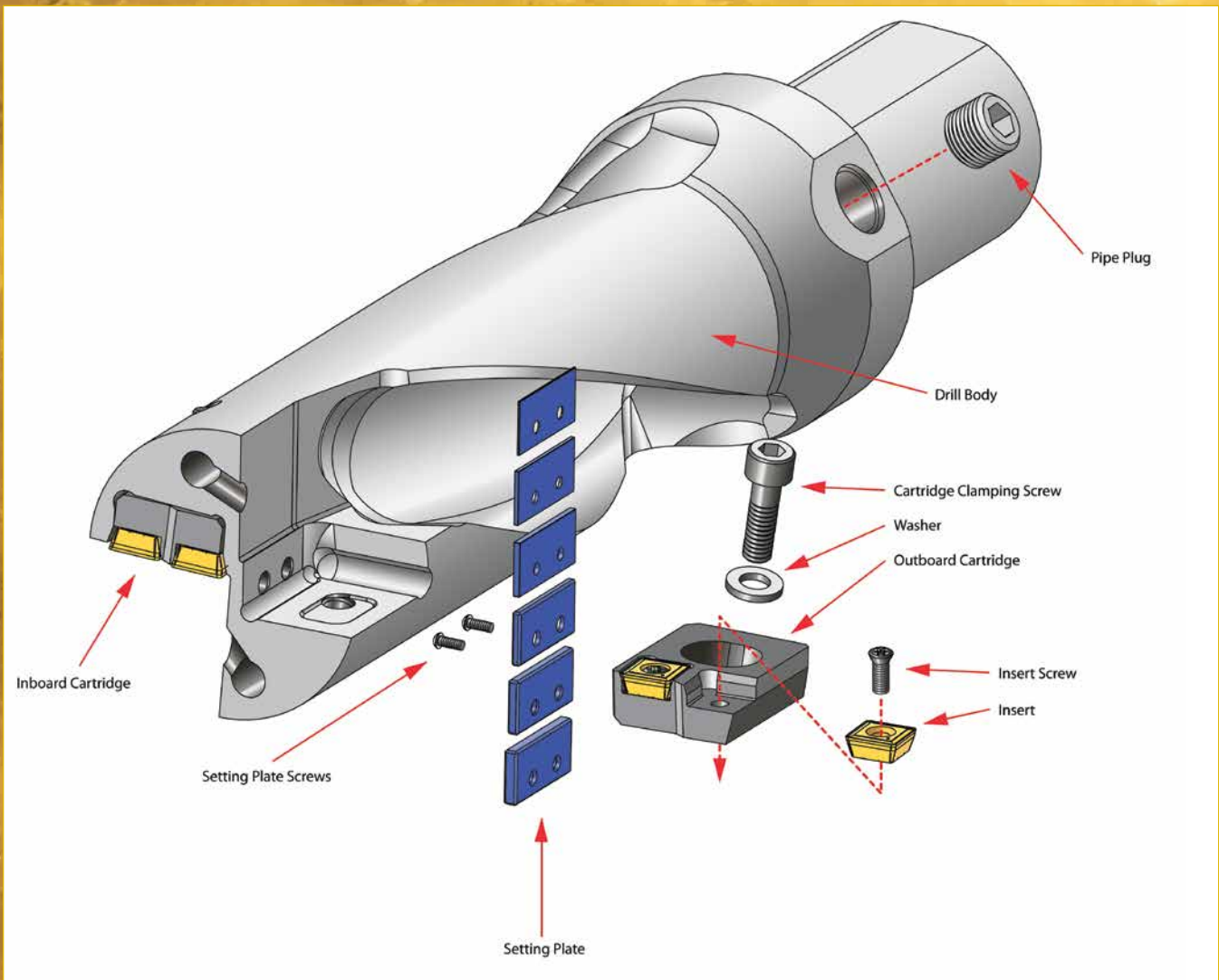

2XD ADJUSTABLE CARTRIDGE DRILL SERIES QA

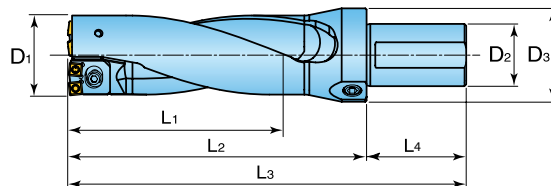

Drill Number	Dimensions (inch)						# of inserts	Setting Plates		Cartridge		
	D1	L1	L2	L3	L4	D2		D3	Part Number	Plate Thickness	Outboard	Inboard
QA0540111N8R01	2.125	4.41	5.98	9.23	3.25	2.000 Universal	2.365	4	-	-	55E223R01	55E213R01
	2.188								DS07-080-01	.031		
	2.250								-	-		
QA0572121N8R01	2.313	4.82	6.69	9.94	3.25	2.000 Universal	2.365	4	DS09-080-01	.031	55F243R02	55F233R01
	2.375								DS09-159-01	.063		
	2.438								-	-		
QA0619130N8R01	2.500	5.13	7.17	10.42	3.25	2.000 Universal	2.365	4	DS09-080-01	.031	55F263R01	55F243R03
	2.563								DS09-159-01	.063		
	2.625								-	-		
QA0667143N8R01	2.688	5.67	7.99	11.24	3.25	2.000 Universal	2.365	4	DS11-080-01	.031	55G294R01	55G264R01
	2.750								DS11-159-01	.063		
	2.813								DS11-238-01	.094		
	2.875								-	-		
QA0730159N8R01	2.938	6.25	8.27	11.52	3.25	2.000 Universal	2.365	4	DS11-080-01	.031	55H314R00	55H294R00
	3.000								DS11-159-01	.063		
	3.063								DS11-238-01	.094		
	3.125								DS11-320-01	.125		

*Each drill includes all hardware. Order inserts separately.

HARDWARE

Drill Diameter Size Range	Outboard Cartridge	Inboard Cartridge	Cartridge Mounting Screw	Cartridge Mounting Screw Washer	Allen Wrench	Insert Screw	Insert Screw Wrench	Setting Plate Screws	Setting Plate Screw Wrench
2.125-2.188	55E223R01	55E213R01	SD040-16 (M4 X 0.7 X 16MM SHCS)	WA004-01 (4.3MM X 8MM)	L-W3 (3MM)	SM25-064-00	DS-T08W (Tx-08)	SM20-043-00	DS-TP06S (TxP-06)
2.250-2.375	55F243R02	55F233R01	SD050-16 (M5 X 0.8 X 16MM SHCS)	WA005-01 (5.5MM X 10MM)	L-W4 (4MM)	SM35-088-60	DS-T10T (Tx-10)	SM30-055-10	DS-T09W (Tx-09)
2.437-2.563	55F263R01	55F243R03	SD050-16 (M5 X 0.8 X 16MM SHCS)	WA005-01 (5.5MM X 10MM)	L-W4 (4MM)	SM35-088-60	DS-T10T (Tx-10)	SM30-055-10	DS-T09W (Tx-09)
2.625-2.813	55G294R01	55G264R01	SD060-20 (M6 X 1 X 20MM SHCS)	WA006-01 (6.4 MM X 12MM)	L-W5 (5MM)	SM40-093-20	DS-T15T (Tx-15)	SM30-055-10	DS-T09W (Tx-09)
2.875-3.125	55H314R00	55H294R00	SD060-20 (M6 X 1 X 20MM SHCS)	WA006-01 (6.4 MM X 12MM)	L-W5 (5MM)	SM40-093-20	DS-T15T (Tx-15)	SM30-055-10	DS-T09W (Tx-09)

3XD ADJUSTABLE CARTRIDGE DRILL SERIES QA

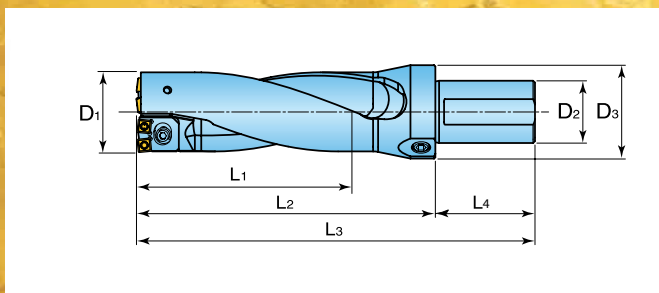

Drill Number	Dimensions (inch)						# of inserts	Setting Plates		Cartridge		
	D1	L1	L2	L3	L4	D2		D3	Part Number	Plate Thickness	Outboard	Inboard
QA0540167N8R01	2.125 2.188	6.61	8.19	11.44	3.25	2.000 Universal	2.365	4	-	-	55E223R01	55E213R01
	2.250								-	-		
QA0572181N8R01	2.313 2.375	7.23	9.13	12.38	3.25	2.000 Universal	2.365	4	DS09-080-01	.031	55F243R02	55F233R01
	2.438								-	-		
QA0619195N8R01	2.500 2.563	7.69	9.76	13.01	3.25	2.000 Universal	2.365	4	DS09-080-01	.031	55F263R01	55F243R03
	2.625								-	-		
QA0667214N8R01	2.688 2.750 2.813	8.50	10.87	14.12	3.25	2.000 Universal	2.365	4	DS11-080-01	.031	55G294R01	55G264R01
	2.875								-	-		
QA0730238N8R01	2.938 3.063 3.125	9.38	11.42	14.67	3.25	2.000 Universal	2.365	4	DS11-080-01	.031	55H314R00	55H294R00
	3.000								DS11-159-01	.063		
	3.063								DS11-238-01	.094		
	3.125								DS11-320-01	.125		

*Each drill includes all hardware. Order inserts separately.

HARDWARE

Drill Diameter Size Range	Outboard Cartridge	Inboard Cartridge	Cartridge Mounting Screw	Cartridge Mounting Screw Washer	Allen Wrench	Insert Screw	Insert Screw Wrench	Setting Plate Screws	Setting Plate Screw Wrench
2.125-2.188	55E223R01	55E213R01	SD040-16 (M4 X 0.7 X 16MM SHCS)	WA004-01 (4.3MM X 8MM)	L-W3 (3MM)	SM25-064-00	DS-T08W (Tx-08)	SM20-043-00	DS-TP06S (TxP-06)
2.250-2.375	55F243R02	55F233R01	SD050-16 (M5 X 0.8 X 16MM SHCS)	WA005-01 (5.5MM X 10MM)	L-W4 (4MM)	SM35-088-60	DS-T10T (Tx-10)	SM30-055-10	DS-T09W (Tx-09)
2.437-2.563	55F263R01	55F243R03	SD050-16 (M5 X 0.8 X 16MM SHCS)	WA005-01 (5.5MM X 10MM)	L-W4 (4MM)	SM35-088-60	DS-T10T (Tx-10)	SM30-055-10	DS-T09W (Tx-09)
2.625-2.813	55G294R01	55G264R01	SD060-20 (M6 X 1 X 20MM SHCS)	WA006-01 (6.4 MM X 12MM)	L-W5 (5MM)	SM40-093-20	DS-T15T (Tx-15)	SM30-055-10	DS-T09W (Tx-09)
2.875-3.125	55H314R00	55H294R00	SD060-20 (M6 X 1 X 20MM SHCS)	WA006-01 (6.4 MM X 12MM)	L-W5 (5MM)	SM40-093-20	DS-T15T (Tx-15)	SM30-055-10	DS-T09W (Tx-09)

INSERTS

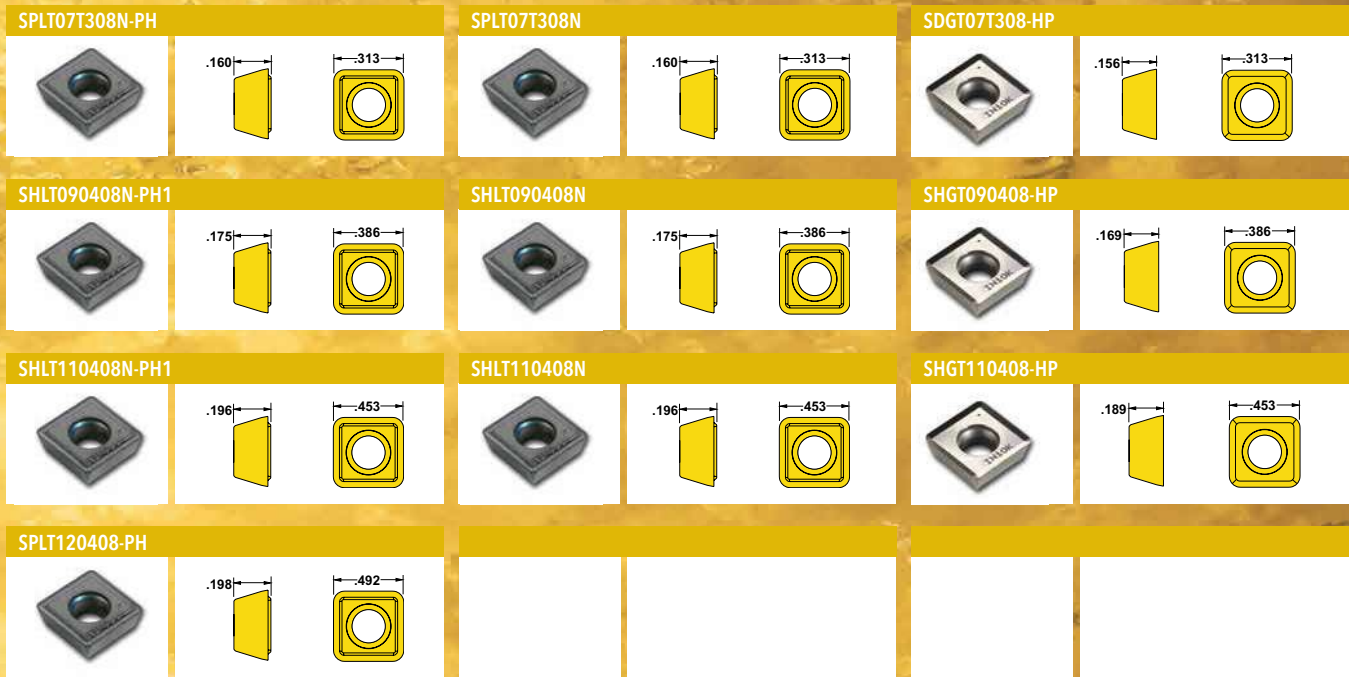

Drill Diameter Range	Insert Number (n)	Cast Iron Inserts Grade IN2010 only (s)	Aluminum Inserts Grade IN10K only (l)	Corner	Grades				
					1030	2005	2010	6520	10K
2.125-2.188	SPLT07T308N-PH	SPLT07T308N	SDGT07T308-HP	.030R	•	•	•	•	•
2.250-2.563	SHLT090408N-PH1	SHLT090408N	SHGT090408-HP	.030R	•	•	•	•	•
2.625-2.813	SHLT110408N-PH1	SHLT110408N	SHGT110408-HP	.030R	•	•	•	•	•
2.875-3.125	SPLT120408N-PH	-	-	.030R	•				

Grade	Application
IN2005	General Purpose
IN1030	For use in unstable conditions, low SFM
IN6520	Peripheral pocket only, more wear resistance
IN2010	Cast iron applications
IN10K	Aluminum, non-ferrous materials

CARTRIDGE-STYLE (DIA. OVER 2.125") RECOMMENDED CUTTING CONDITIONS

ISO	Material	Condition	Tensile Strength Rm (N/mm ²)	Hardness (HB)	Matl No.	Cutting Speed Vc (SFM)	Feed vs. Drill Diameter Inch/Rev Drill Length 2xD, 3xD			
							Ø 2.125 (inch)	Ø 2.250-2.750 (inch)	Ø 2.875-3.000 (inch)	Ø 3.250 (inch)
P	Non-alloy steel <0.25% C & cast steel, >= 0.25% C free cutting steel >= 0.55% C	Annealed	420	125	1	800-1000	.002-.003	.002-.003	.002-.004	.002-.004
		Annealed	650	190	2	800-1000	.003-.004	.003-.004	.003-.005	.003-.005
		Quenched & Tempered	850	250	3	500-800	.003-.005	.003-.005	.003-.006	.003-.006
		Annealed	750	220	4	800-1000	.003-.005	.003-.005	.003-.006	.003-.006
		Quenched & Tempered	1000	300	5	600-800	.003-.005	.003-.005	.003-.006	.003-.006
	Low alloy steel & cast steel (less than 5% alloying elements)	Annealed	600	200	6	500-800	.003-.006	.003-.006	.003-.007	.003-.007
		Quenched & Tempered	930	275	7	400-700	.003-.006	.003-.006	.003-.008	.003-.008
			1000	300	8	400-600	.003-.006	.003-.006	.003-.008	.003-.008
			1200	350	9	300-550	.003-.006	.003-.006	.003-.008	.003-.008
	High alloy steel, cast steel, & tool steel	Annealed	680	200	10	400-600	.002-.005	.0025-.005	.0025-.005	.003-.006
Quenched & Tempered		1100	325	11	400-550	.0025-.005	.0025-.005	.003-.006	.003-.006	
M	Stainless steel & cast stainless steel	Ferritic/Martensitic	680	200	12	550-800	.0035-.007	.004-.008	.005-.085	.003-.006
		Martensitic	820	240	13	500-700	.0035-.007	.004-.008	.005-.085	.003-.006
		Austenitic	600	180	14	500-700	.0035-.007	.004-.008	.005-.085	.003-.006
K	GreyCast Iron (GG)	Ferritic		160	15	500-800	.006-.0095	.007-.012	.007-.013	.0085-.014
		Pearlitic		250	16	500-800	.006-.0095	.007-.012	.007-.013	.0085-.014
	Cast Iron Nodular (GGG)	Ferritic		180	17	600-800	.006-.0095	.007-.012	.007-.013	.0085-.014
		Pearlitic		260	18	600-800	.006-.0095	.007-.012	.007-.013	.0085-.014
	Malleable Cast Iron	Ferritic		130	19	600-800	.006-.0095	.007-.012	.007-.013	.0085-.014
		Pearlitic		230	20	500-700	.006-.0095	.007-.012	.007-.013	.0085-.014
N	Aluminum - wrought alloy	Not cureable		60	21	1300-2000	.005-.0095	.006-.011	.0065-.011	.007-.012
		Cured		100	22	1000-1300	.005-.0095	.006-.011	.0065-.011	.007-.012
	Aluminum - cast, alloyed <=12% Si >12% Si	Not cureable		75	23	1300-2000	.005-.0095	.006-.011	.0065-.011	.007-.012
		Cured		90	24	1000-1300	.005-.0095	.006-.011	.0065-.011	.007-.012
		High temperature		130	25	1000-1300	.005-.0095	.006-.011	.0065-.011	.007-.012
		Free cutting		110	26	800-1000	.005-.0095	.006-.011	.0065-.011	.007-.012
	Copper alloys > 1% Pb	Brass		90	27	750-900	.005-.0095	.006-.011	.0065-.011	.007-.012
		Electrolitic copper		100	28	800-1000	.005-.0095	.006-.011	.0065-.011	.007-.012
		Duro & fiber plastics			29					
	Non-metallic	Hard rubber			30					
S		High temp alloys Fe based Ni or Co based	Annealed		200	31	100-250	.0035-.0085	.005-.010	.006-.011
	Cured			280	32	100-250	.0035-.0085	.005-.010	.006-.011	.007-.0115
	Annealed			250	33	100-250	.0035-.0085	.005-.010	.006-.011	.007-.0115
	Cured			350	34	100-250	.0035-.0085	.005-.010	.006-.011	.007-.0115
	Cast			320	35	100-250	.0035-.0085	.005-.010	.006-.011	.007-.0115
	Titanium, Ti alloys	Alpha+beta alloys cured	Rm 400		36	100-250	.0035-.0085	.005-.010	.006-.011	.007-.0115
H	Hardened steel	Hardened		55 HRC	38	50-150	.001-.0035	.0025-.0035	.0025-.0035	.0025-.0045
		Hardened		60 HRC	39	50-150	.001-.0035	.0025-.0035	.0025-.0035	.0025-.0045
	Chilled cast iron	Cast		400	40	50-150	.001-.0035	.0025-.0035	.0025-.0035	.0025-.0045
	Cast iron nodular	Hardened		55 HRC	41	50-150	.001-.0035	.0025-.0035	.0025-.0035	.0025-.0045

DEEPTWIST™

DEEP DRILL

HF SERIES DEEP DRILL



INSERT GRADE APPLICATIONS

IN6542	P25	P20-30	CVD 3-Layered	Steel Alloyed Steel Steel Coating
IN1510	M30	K15-25 M35-40 P30-40 S15-25	PVD-TiCN	Stainless HRSA Cast iron
IN2005	P30	M10-30 P15-35	PVD-TiAlN	Multipurpose

Large coolant hole facilitates excellent coolant supply

Curved flute design for good chip evacuation

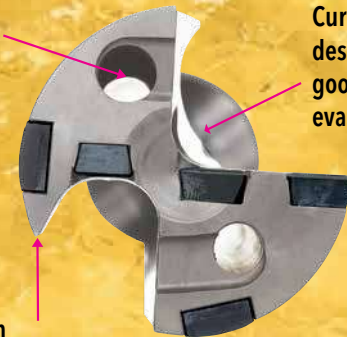

Optimal design to reduce chip jamming

INSERTS

D	Outer	Insert Inner	Center	Guide Pad
30 - 33	NPMT06504R2	NPMT06504R2	NPMT06504L2	PAD-GO-07CD
33.01 - 36	NPMT06504R2	NPMT06504R2	NPMT0804L2	PAD-GO-07CD
36.01 - 39	NPMT0804R2	NPMT06504R2	NPMT0804L2	PAD-GO-07CD
39.01 - 42	NPMT0804R2	NPMT0804R2	NPMT0804L2	PAD-GO-08CD
42.01 - 45	NPMT0804R2	NPMT0804R2	NPMT09504L2	PAD-GO-08CD
45.01 - 48	NPMT09504R2	NPMT0804R2	NPMT09504L2	PAD-GO-10CD
48.01 - 51	NPMT09504R2	NPMT09504R2	NPMT09504L2	PAD-GO-10CD
51.01 - 57	NPMT09504R2	NPMT09504R2	NPMT12504L2	PAD-GO-10CD
57.01 - 63	NPMT12504R2	NPMT09504R2	NPMT12504L2	PAD-GO-12CD
63.01 - 69	NPMT12504R2	NPMT12504R2	NPMT12504L2	PAD-GO-12CD

HF SERIES DEEP DRILL

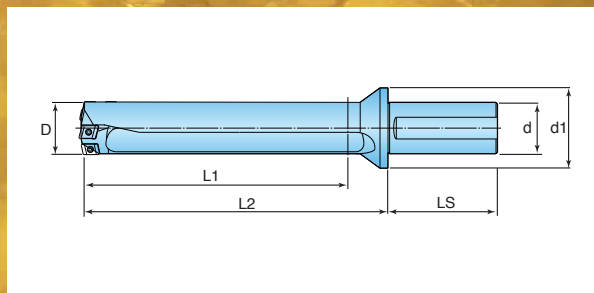

Description	D"	D mm	Dimensions (inch)					
			L1	L2	LS	d	d1	L/D
HF0300420N6R01	1.181	30	16.54	17.68	2.36	1.25	1.77	14
HF0310420N6R01	1.220	31	16.54	17.68	2.36	1.25	1.77	13
HF0318420N7R01	1.250	31.8	16.54	17.68	2.76	1.50	2.17	13
HF0320420N7R01	1.260	32	16.54	17.68	2.76	1.50	2.17	13
HF0330420N7R01	1.299	33	16.54	17.68	2.76	1.50	2.17	12
HF0340420N7R01	1.339	34	16.54	17.72	2.76	1.50	2.17	12
HF0350420N7R01	1.378	35	16.54	17.72	2.76	1.50	2.17	12
HF0360420N7R01	1.417	36	16.54	17.72	2.76	1.50	2.17	12
HF0370420N7R01	1.457	37	16.54	17.83	2.76	1.50	2.17	11
HF0380420N7R01	1.496	38	16.54	17.83	2.76	1.50	2.17	11
HF0381420N7R01	1.500	38.1	16.54	17.83	2.76	1.50	2.17	11
HF0390420N7R01	1.535	39	16.54	17.83	2.76	1.50	2.17	10
HF0400420N7R01	1.575	40	16.54	17.87	2.76	1.50	2.17	10
HF0410420N7R01	1.614	41	16.54	17.87	2.76	1.50	2.17	10
HF0420420N7R01	1.654	42	16.54	17.87	2.76	1.50	2.17	10
HF0430420N7R01	1.693	43	16.54	17.95	2.76	1.50	2.17	9
HF0440420N7R01	1.732	44	16.54	17.95	2.76	1.50	2.17	9
HF0445420N7R01	1.750	44.5	16.54	17.95	2.76	1.50	2.17	9
HF0450420N7R01	1.772	45	16.54	17.95	2.76	1.50	2.17	9
HF0460420N7R01	1.811	46	16.54	18.07	2.76	1.50	2.17	9
HF0470420N7R01	1.850	47	16.54	18.07	2.76	1.50	2.17	8
HF0480420N7R01	1.890	48	16.54	18.07	2.76	1.50	2.17	8
HF0490420N7R01	1.929	49	16.54	18.15	2.76	1.50	2.17	8

HF SERIES DEEP DRILL

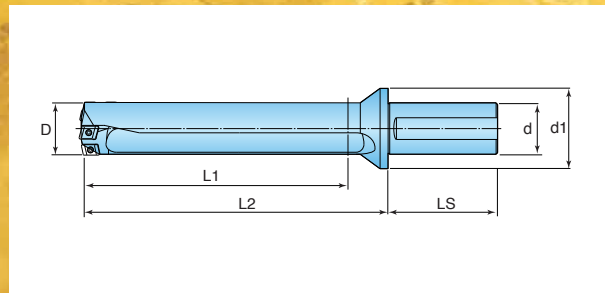

Description	D"	D mm	Dimensions (inch)					
			L1	L2	LS	d	d1	L/D
HF0500420N7R01	1.969	50	16.54	18.15	2.76	1.50	2.17	8
HF0508420N7R01	2.000	50.8	16.54	18.15	2.76	1.50	2.17	8
HF0510420N7R01	2.008	51	16.54	18.15	2.76	1.50	2.17	8
HF0520420N7R01	2.047	52	16.54	18.27	2.76	1.50	-	8
HF0530420N7R01	2.087	53	16.54	18.27	2.76	1.50	-	7
HF0540420N7R01	2.126	54	16.54	18.27	2.76	1.50	-	7
HF0550420N7R01	2.165	55	16.54	18.27	2.76	1.50	-	7
HF0560420N7R01	2.205	56	16.54	18.27	2.76	1.50	-	7
HF0570420N7R01	2.244	57	16.54	18.27	2.76	1.50	-	7
HF0571420N7R01	2.248	57.1	16.54	18.27	2.76	1.50	-	7
HF0580420N7R01	2.283	58	16.54	18.50	2.76	1.50	-	7
HF0590420N7R01	2.323	59	16.54	18.50	2.76	1.50	-	7
HF0600420N7R01	2.362	60	16.54	18.50	2.76	1.50	-	7
HF0610420N7R01	2.402	61	16.54	18.50	2.76	1.50	-	6
HF0620420N7R01	2.441	62	16.54	18.50	2.76	1.50	-	6
HF0630420N7R01	2.48	63	16.54	18.50	2.76	1.50	-	6
HF0635420N7R01	2.500	63.5	16.54	18.50	2.76	1.50	-	6
HF0640420N7R01	2.520	64	16.54	18.62	2.76	1.50	-	6
HF0650420N7R01	2.559	65	16.54	18.62	2.76	1.50	-	6
HF0660420N7R01	2.598	66	16.54	18.62	2.76	1.50	-	6
HF0670420N7R01	2.638	67	16.54	18.62	2.76	1.50	-	6
HF0680420N7R01	2.677	68	16.54	18.62	2.76	1.50	-	6
HF0690420N7R01	2.716	69	16.54	18.62	2.76	1.50	-	6

301

Member IMC Group
Ingersoll
Cutting Tools

Member IMC Group
Ingersoll
Cutting Tools

Ingersoll Cutting Tools For Americas

Marketing & Technology Center
845 S. Lyford Road
Rockford, IL 61108-2749 U.S.A.
Tel: 815.387.6600
Fax: 815.387.6968
Email: info@ingersoll-imc.com
Internet: www.ingersoll-imc.com

Ingersoll Mexico

Bldv. Cuauhtemoc Num 2411 Locales 6 y 7
Esquina Calle Manuel Perez Trevino
Fracc. Residencial Los Pinos
CP 25198
Saltillo, Coahuila, Mexico
Tel: +52-844-4-85-32-20
Fax: +52-844-4-85-32-23
Email: info@ingersoll-imc.com

Ingersoll Cutting Tools For Europe

Marketing & Technology Center
Ingersoll Werkzeuge GmbH
Kalteiche-Ring 21-25
35708 Haiger, Germany
Tel: 02773.742 0
Fax: 02773.742 812/814
Email: info@ingersoll-imc.de
Internet: www.ingersoll-imc.de

Ingersoll France s.a.r.l.

21, rue Galilée
F-77420 CHAMPS-sur-MARNE
Tel: +33 (0)1 64 68 45 36
Fax: +33 (0)1 64 68 45 24
Email: info@ingersoll-imc.fr

Ingersoll Italien

Via Monte Grappa, 78
20020 Arese (Milano)
Telefon: +39 02 99 76 67 00
Telefax: +39 02 99 76 67 10
Email: crespi@taegutec.it

Ingersoll Cutting Tools For Asia

Ingersoll Japan Ltd.

Senri Asahi Hankyu Bldg. 15F
1-5-3 Shinsenri-Higashimachi
Toyonaka-shi Osaka 560-0082
Tel: 81-6-6835-7731
Fax: 81-6-6835-7732

Ingersoll China

7B21,
hanwei Plaza,
GuangHua Road,
Chaoyang District,
Beijing, P.R.C, 100004.
Tel: +86 10 656 10261/2/3
Fax: +86 10 656 10264

